

# RADIO NEWS

AUGUST  
1943  
25c  
In Canada 30c

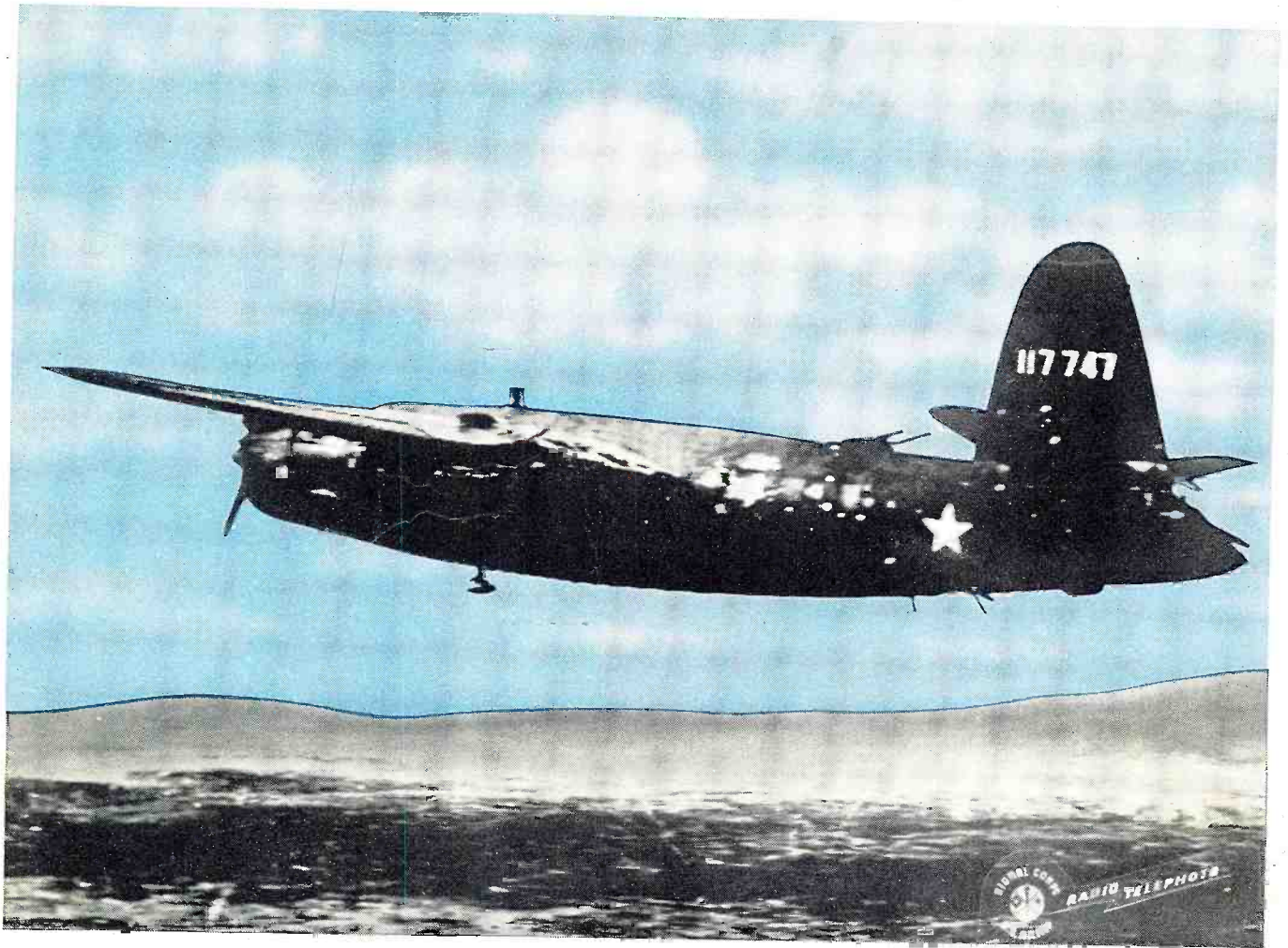



## THIS BATTERED BOMBER CAME BACK

because the Electrical Connectors  
could "take it"

AMPHENOL CONNECTORS, QUICK POSITIVE  
CONNECTIONS FOR ELECTRICAL CIRCUITS

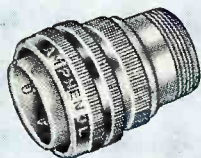

AN-3106



AN-3102



AN-3108

This Martin Marauder flew through shattering flak to carry out its mission over Tunisia. Jarred, battered, torn—it still returned to its base—a tribute to the ability of American enterprise to produce the best planes in the world.

Of great importance in this feat were the electrical connectors—vital in maintaining controls and communications. Amphenol A-N Connectors are used in Martin Bombers.

AMERICAN PHENOLIC CORPORATION, CHICAGO  
IN CANADA—AMPHENOL LIMITED, TORONTO

# AMPHENOL

A-N ELECTRICAL CONNECTORS • CONDUIT • FITTINGS • LOW-LOSS INSULATION

**Men NOW in Radio  
who Don't Think  
they know it All  
Read This**

If you're a Serviceman you don't want to lose Radio repair business because you lack TECHNICAL knowledge. You want to cash in on wartime opportunities and get ready for peacetime developments. If you're an Operator, you don't want to be baffled by new Radio circuits and equipment. You want the EXTRA knowledge that wins promotions, extra pay. Read my message below—then MAIL COUPON!

**If You're NOT  
Working in Radio Now  
Read This**

You can begin cashing in on your interest in Radio QUICKLY—IF YOU ACT NOW! The Radio repair business, a busy field because no new home and auto Radios are being made, offers more opportunities than ever to make \$50 a week in full time jobs, or \$5 to \$10 extra in spare time. Practically all branches of Radio need Technicians or Operators or both. Find out how I train you at home in spare time to be a Radio Technician or Operator. Read my message below—then MAIL COUPON.



J. E. SMITH  
President, National Radio Institute  
Established 28 Years



**Extra Pay in Army, Navy, Too**

Men likely to go into military service, soldiers, sailors, marines, should mail the coupon now! Learning Radio helps get extra rank, extra prestige, more interesting duties, MUCH HIGHER PAY. Also prepares for good Radio jobs after service ends. Over 1700 Servicemen now enrolled.



**Make Me Prove I Can Train You at Home  
to Be a RADIO TECHNICIAN or OPERATOR**

**FREE RADIO LESSON**

Here is a Partial List of Subjects This Lesson Teaches with 31 Photos, Sketches, Radio Drawings.

- How superheterodyne receivers work
- How to remove tubes, tube shields
- Three reasons why Radio tubes fail
- Electrodynamic loud-speaker:
- How it works
- Replaced damaged cone
- Recentering voice coil
- Remedies for open field coil
- Output transformer construction, repair
- Gang tuning condenser: Construction of rotor, stator
- How capacity varies
- Restringing dial cord
- Straightening bent rotor plates
- I. F. transformers—What they do, repair hints
- How to locate defective soldered joints
- Inside story of carbon resistors
- Paper, electrolytic, mica, trimmer condensers
- How condensers become shorted, leaky
- Antenna, oscillator coil facts
- Power transformer, construction, possible troubles
- Installing power cord
- Troubles of combination volume control, on-off switch
- Tone controls
- Dial lamp connections
- Receiver servicing technique:
- Circuit disturbance test
- Testing tubes
- Checking performance
- Isolating defective stage
- Locating defective part

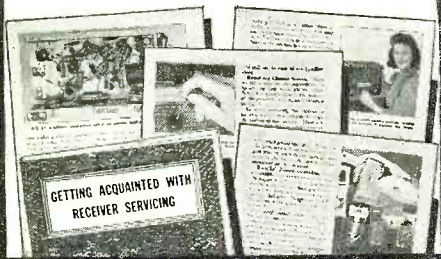

Whether you're a beginner, or already in Radio—whether you want your own Radio business or a good Radio job—mail the Coupon for a FREE Lesson from my Radio Course. I want you to see for yourself how clear my Course is—see how it's planned to help you become a successful Radio Technician or Operator. And with this sample lesson I'll send my 64-page illustrated book, "Win Rich Rewards in Radio." It describes the many fascinating jobs Radio offers; explains my unique training method.

My method has helped many men already in Radio. Charles F. Helmuth, 16 Hobart Ave., Absecon, N. J., writes: "I started Radio in the Marines. Later, I took the N.R.I. Course. Now I am my own boss. I owe plenty to N.R.I. training." It has helped hundreds of beginners, too. Here is what James E. Ryan, 119 Pebble Court, Fall River, Mass., writes: "I was working in a garage when I enrolled with N.R.I. I am now Radio Service Manager of 4 stores." My FREE book contains more than 100 letters like these from men I trained. They show that N.R.I. gives real help!

**More Radio Technicians and Operators  
Now Make \$50 a Week Than Ever Before**

There's a big shortage of capable Radio Technicians and Operators because so many have joined the Army and Navy. Fixing Radios pays better now than for years. With new Radios out of production, fixing old sets, which were formerly traded in, adds greatly to the normal number of servicing jobs.

Broadcasting Stations, Aviation and Police Radio.

Ship Radio and other communications branches are scrambling for Operators and Technicians to replace men who are leaving. You may never see a time again when it will be so easy to get started in this fascinating field. The Government, too, needs hundreds of competent civilian and enlisted Radio men and women. Radio factories, with huge war orders to fill, have been advertising for trained personnel. And think of the NEW jobs Television, Frequency Modulation, and Electronics will open after the war! This is the sort of opportunity you shouldn't pass up.

**Many Beginners Soon Make \$5, \$10  
a Week Extra in Spare Time**

There's probably an opportunity right in your neighborhood to make money in spare time fixing Radios. I'll give you the training that has started hundreds of N.R.I. students making \$5, \$10 a week extra within a few months after enrolling. The N.R.I. Course isn't something just prepared to take advantage of the present market for technical books and courses. It has been tried, tested, developed, perfected, during the 25 years we have been teaching Radio.

**Find Out What N.R.I. Can Do for You**

MAIL COUPON NOW for FREE Sample Lesson and 64-page illustrated book. See the many fascinating jobs Radio offers and how YOU can train at home. If you want to jump your pay—mail Coupon in an envelope or paste on a penny postal!—J. E. SMITH, President, Dept. 3HR, National Radio Institute, Washington-9, D. C.

**TRAINING MEN FOR VITAL RADIO JOBS**

**GOOD FOR BOTH 64 PAGE BOOK FREE  
SAMPLE LESSON FREE**

J. E. SMITH, President, Dept. 3HR  
National Radio Institute  
Washington-9, D. C.

Dear Mr. Smith: Mail me FREE without obligation, your Sample Lesson and 64-page book, "Win Rich Rewards in Radio," which tells about Radio's spare time and full time opportunities and tells how you train men at home to be Radio Technicians. (No salesman will call.)

I AM doing Radio Work.  I am NOT doing Radio work.

Name..... Age.....  
Address.....  
City..... State..... 4FR



## C O N T E N T S

**FEATURES**

THE ARMY'S SCR-299.....	Oliver Read	17
WIDE BAND AMPLIFIER DESIGN.....	Edward J. Bukstein	21
AIR-RAID ALARM CIRCUITS.....	Willard D. Stewart	23
THE SAGA OF THE VACUUM TUBE.....	Gerald F. J. Tyne	26
ELECTRONIC MEASUREMENTS.....	Clark E. Jackson	28
SCIENTIFIC FARMING.....	S. R. Winters	30
DELAY AND TIMING CIRCUITS.....	Rufus P. Turner	32
ELECTRO-MEDICAL APPARATUS.....	John Kane	35
WAR—BY RADIO.....	S. L. Solon	37
RADIOMEN IN COMBAT.....		40
HOW COLOR COMPARATORS WORK.....	John Keating	41
VARIABLE INDUCTORS.....	Guy Dexter	43

**DEPARTMENTS**

PRACTICAL RADIO COURSE, PART 16....	Alfred A. Ghirardi	38
MRFS.' LITERATURE ....	37	BOOK REVIEW ..... 40
WHAT'S NEW IN RADIO..	42	SPOT RADIO NEWS..... 8

Cover—Radio Technician, U. S. Marine Corps Photo

WM. B. ZIFF, *Publisher*                      B. G. DAVIS, *Editor*                      C. R. TIGHE, *Ass't to Publisher*

OLIVER READ, W9ETI  
*Managing Editor*

WM. A. STOCKLIN <i>Associate Editor</i>	R. B. FRANK, W9JU <i>Tech. Ed. (on leave)</i>	JOE MARTY, JR. <i>Assistant Editor</i>	J. M. ECKERT <i>Assistant Editor</i>
K. R. PORTER <i>War Correspondent</i>	HERMAN R. BOLLIN <i>Art Director</i>	S. L. CAHN <i>Advertising Mgr.</i>	H. G. STRONG <i>Circulation Director</i>

Copyright, 1943  
ZIFF-DAVIS PUBLISHING COMPANY  
Editorial Offices: 540 N. Michigan Ave., Chicago, Ill.  
Member of the Audit Bureau of Circulations

RADIO NEWS is published monthly by the Ziff-Davis Publishing Company at 540 N. Michigan Ave., Chicago, Ill. New York Office, 270 Madison Ave. Washington, D. C., Office, Earle Bldg. Special Washington Representative, Col. Harold E. Hartney, Occidental Hotel. London Editorial Representative, A. Spenser Allberry. Subscription Rates: In U. S. \$3.00 per year, single copies, 25 cents; in South and Central America and U. S. Possessions, \$3.00 per year; in Canada \$3.50 per year, single copies 30 cents; in British Empire, \$4.00 per year; all other foreign countries \$6.00 per year. Subscribers should allow at least 2 weeks for change of address. All communications about subscriptions should be addressed to: Director of Circulation, 540 N. Michigan Ave., Chicago, Ill. Entered as second class matter March 9, 1938, at the Post Office, Chicago, Illinois, under the Act of March 3, 1879. Entered as second class matter at the Post Office Department, Ottawa, Canada. Contributors should retain a copy of contributions. All submitted material must contain return postage. Contributions will be handled with reasonable care, but this magazine assumes no responsibility for their safety. Accepted material is subject to whatever adaptations, and revisions, including "by-line" changes, necessary to meet requirements. Payment covers all authors, contributors or contestants' rights, title, and interest in and to the material accepted and will be made at our current rates upon acceptance. All photos and drawings will be considered as part of material purchased.



**T**HE acceptance of FM for post-war broadcast channels may be weakened by a newly perfected "static eliminator" now being used by our Army and Navy to combat all types of man-made interferences and the noises created by lightning.

FM receivers were accepted in recent years largely because of their ability to receive programs in noisy areas clearly and without static and other disturbances. The other selling point was that the audio-frequency range would include the full treble and bass frequencies as they appear at the original source in the studio.

If this new static eliminator becomes highly perfected, and we believe that it will, it will in large measure affect the sale of FM receivers where the customer is chiefly interested in listening to his programs without disturbing noises coming through his loud-speaker.

The regular broadcasters of AM will be able to keep the goodwill of their listeners, particularly in rural areas, if programs can be received that are free from static. The greater coverage of present AM transmitters is another selling point to consider. The static eliminator, developed by G. J. C. Andresen, Goodyear research physicist, was demonstrated by creating interference by means of spark coil close to the antenna of an ordinary radio set. Without the unit, the interference completely drowned out the program which was being received. The terrific interference reduced to a very slight buzz when the unit was switched in. Even a 25,000 volt spark from an airplane engine ignition system was effectively reduced to insignificance as far as its interference was concerned. This radionic unit has the ability to discriminate between static and the desired signals, and is capable of rapid automatic control of the amount of static on the same frequency as the incoming signal by permitting the energy of the static itself to generate a current of opposite electrical polarity. This in turn neutralizes the static.

(Continued on page 68)

# ARHCO Varieties of 1943

## 2008 Wartime Essentials

We do stamping, screw machine work, moulding, and general Radio and Radar communications assemblies. Illustrated are but a mere handful of the 2008 wartime essentials which we are now manufacturing. Your inquiries will receive prompt attention.

Now, more than ever, it is important that you keep on buying War Bonds and Stamps.



*American  
Radio  
Hardware* CO., INC.

476 BROADWAY, NEW YORK, N. Y.

MANUFACTURERS OF SHORT WAVE • TELEVISION • RADIO • SOUND EQUIPMENT.

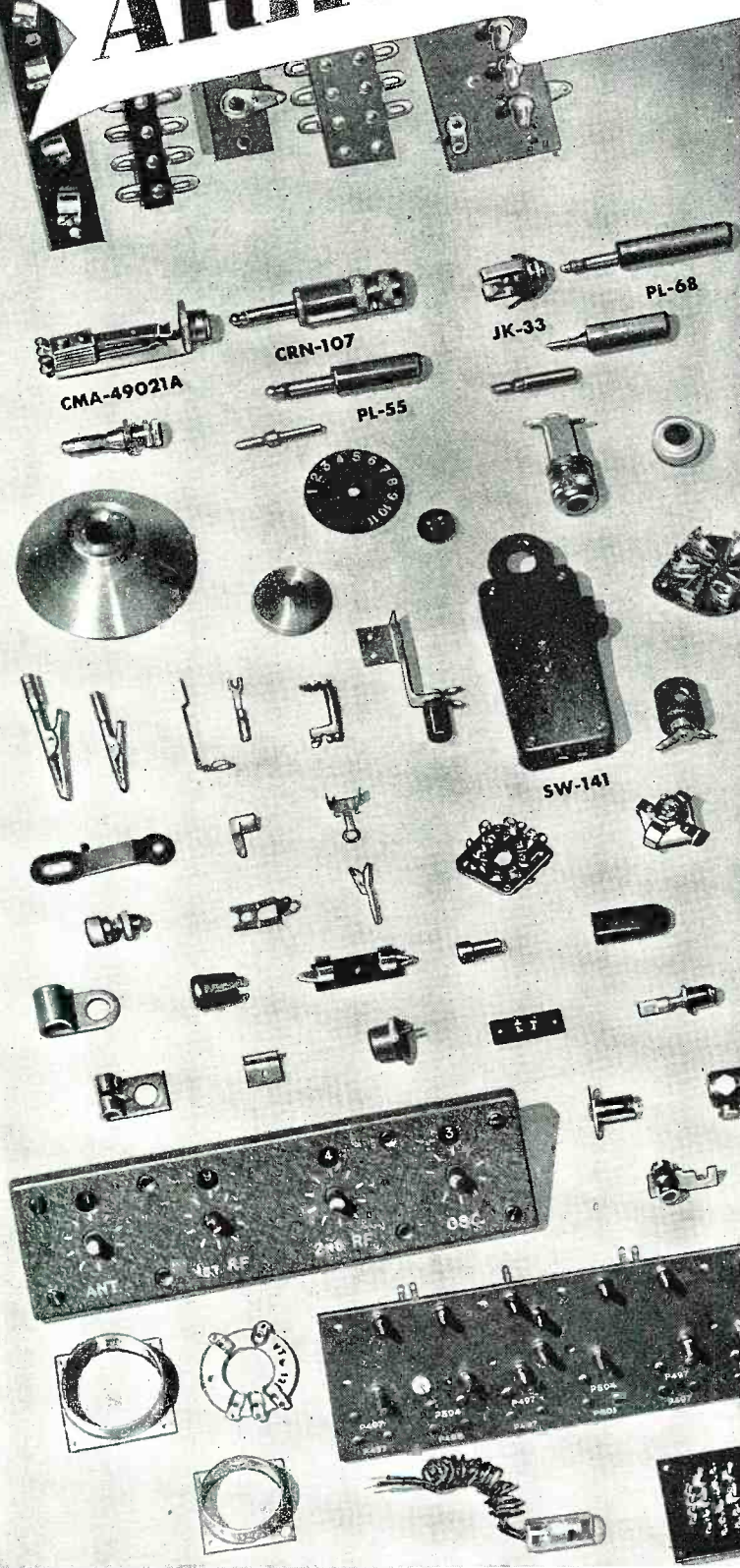

# after **V**ictory . . .

A STATEMENT BY E. A. TRACEY, PRESIDENT  
MAJESTIC RADIO AND TELEVISION CORPORATION, CHICAGO



Since five months before Pearl Harbor, Majestic has been engaged in war production. The "Walkie-Talkie," famous radio of the firing

line, and airplane marker beacons are Majestic products. Our engineers have developed, and our factory has built, several different types of communications equipment. Thousands of quartz crystals are being produced. Majestic has placed its entire facilities, resources and personnel exclusively at our government's disposal. All this has made its mark upon the Majestic organization. There are new names in executive positions,—names of men that are well known throughout the radio industry for their accomplishments in engineering and production, that are accustomed to doing things largely and well. In its key positions, Majestic is today one of the strongest organizations in our industry.

Under the stress of war time schedules, new standards of production have been established in the Majestic factory. Manufacturing tolerances, requiring precision unheard of in days of civilian radio, are now commonplace, and yet, production rolls from the assembly lines in an unbroken stream and at a higher tempo than ever before. Even so, one hundred per cent capacity is still a mythical figure we have not even approached. Majestic today is a more efficient,—a more capable organization.

After Victory, this strong Majestic organization will turn to civilian radio. Already plans are being prepared and the groundwork is laid.

Tempered in the crucible of war time production, led by dynamic, experienced veterans of the radio industry, with improved facilities and larger resources, Majestic cannot help but be an important, outstanding factor in the post war radio industry.

There will be new luster added to an already famous name in radio.

  
*Majestic*  
MIGHTY MONARCH  
OF THE AIR



*Builders of the Walkie-Talkie—"Radio of the Firing Line"*

# ONE *Expert* TO SEND THE MESSAGE



Miss Gertrude Theberge records results of 955 ultra-high-frequency performance tests.



# ONE *Expert* TO PROVIDE THE EQUIPMENT

Specialists on the Factory Front must back up those on the Fighting Front. As an American, you would be proud to see at Hytron carefully trained girls holding down important supervisory and technical jobs, and displaying manual dexterity on fine work which a watchmaker would admire.

Here at Hytron we realize fully our responsibility for fashioning well the radar, radio, and electronic tubes upon whose performance the lives of our fighting men depend. To fulfill this trust, we have gone all out to train hundreds of new specialists capable of building to exacting standards countless dependable War tubes. That their skills may help bring closer the day when our boys come marching home, is the sole purpose of all Hytron employees.



VR105-30 and VR150-30  
Gaseous voltage-regulator tubes

*Oldest Exclusive Manufacturer of Radio Receiving Tubes*

# Hytron

ELECTRONIC AND  
RADIO TUBES

# Corporation



SALEM AND NEWBURYPORT, MASS.

Designed for



Application

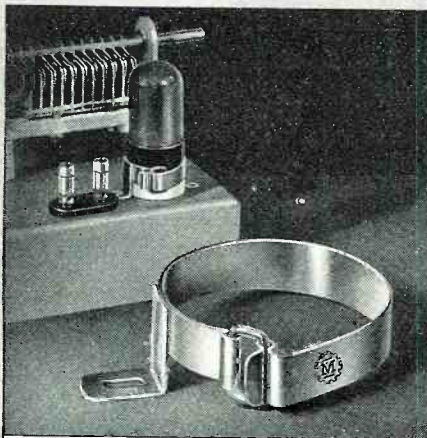

### THE 33087 TUBE CLAMP

Still another exclusive Millen "Designed for Application" product. Easy to use, easy to install, effective in function. Available in special sizes for all types of tubes. Single hole mounting. Spring steel, cadmium plated.

**JAMES MILLEN  
MFG. CO., INC.**

MAIN OFFICE AND FACTORY  
**MALDEN  
MASSACHUSETTS**



# Spot Radio News

**IN DEFENSE AND INDUSTRY**

by **LEWIS WINNER**  
RADIO NEWS Washington Correspondent

*Presenting latest information on the Radio situation.*

**THE VITAL PART THAT RADIO** is playing in Air Transport Service and will continue to play in the future, was revealed in a recent OWI report. According to the report there were 3,000,000 movements of aircraft handled by the Civil Aeronautics Authority traffic control centers in 1938. In 1942, these controlled movements rose to 6,000,000 while in 1943, it is expected that 13 to 14-million such movements will prevail over our airways. And by 1950, the CAA expects to control 60-million aircraft movements. This tremendous increase in traffic will demand an unprecedented provision for control via radio.

At the present time the CAA maintains and operates 408 intermediate-frequency radio range and marker stations, 197 ultra-high frequency radio fan markers and 72 ultra-high frequency radio range stations. The CAA predicts that in 1943 we will have 143 ultra-high frequency radio range stations. At present the CAA operates aircraft control towers at 74 designated fields, which are being increased to 120 or more this year. This is a far cry from the primary methods used in 1921, when the first night transcontinental mail flights took place, using bonfires prepared by obliging farmers as flight guides.

At present the Federal Airways Service operates six intercontinental superradio stations capable of communicating with aircraft at any point on the globe. These stations are located not only within the continental limits of the United States but also in its possessions. They are now being used solely for the war effort to provide weather and navigation information. Their combined range is so great that they can blanket the world and contact planes in flight anywhere on the globe. And this network is being increased to include stations in South America, Africa, Europe, Asia and Australia.

Ultra-high frequencies are seen by the CAA to be an important factor in solving the postwar airway problem. They say that ultra-high frequencies will eliminate static and provide a visual as well as an aural course, if not omnidirectional courses. Other innovations of the proposed postwar plan will be, two voice channels on every radio range station, the employment of ultra-high frequency for traffic control, ultra-high-frequency lo-

calizers for all important airports with glide path, and ultra-high frequency markers to permit the pilot to land under instrument conditions.

It is interesting to note that since 1927 the Civil Airways of the United States have increased more than 700%. For now there are over 35,000 miles of civil airways. It is also interesting to note that although only three years ago the CAA put into operation the first fully developed instrument landing system in Indianapolis, there are now many such systems in operation. And before the close of the year many more will be in operation.

Radio is truly a great friend of the airplane, and as time goes on its relationship becomes closer.

**THAT SUPERSTATION OWNED** by Powell Crosley, which had been the center of controversy for many years both in Congress and in technical circles, has now been recognized as a necessary factor. Authority has been given to reactivate this station and install additional transmitters, providing a total power of 750,000 watts. These stations will operate on short-waves and be directed towards the Axis countries. This new powerful setup should really raise havoc in Italy, Germany and Japan and other Axis countries.

For years this Crosley station operating under an experimental license and with an output of 500,000 watts was the brunt of criticism in many circles. In Washington this authorization of power was criticized as concentrating too much power, in a political and technical way, at one point. Technical groups did not feel that this wattage was absolutely essential in the Cincinnati area. The fact that this power did permit coverage of areas not within reach of broadcasts by other stations, added weight, however, to the necessity of super power in the Middle West. And undoubtedly, at the conclusion of the war, super power will become a vital factor in many areas that cannot be covered with ordinary type transmitters.

**FEAR THAT RADIO PRODUCTION** was on a decline was dispelled recently when a Dow Jones report made its appearance. According to this report radio manufacturing companies have an estimated 6-billion dol-

**RADIO NEWS**





**JAMES**

# *Crystals*

**KNIGHTS**

## **CRYSTAL HEADQUARTERS**

Behind the volume production of James Knights Crystals stands a background of specialized experience nearly as old as radio itself. The service of James Knights Crystals in thousands of vital battlefront positions is a tribute to the modern and carefully engineered facilities which produce them. If you have an essential Crystal problem, these dependable facilities are at your command.

.... Phone 65

**The JAMES KNIGHTS Co.**  
SANDWICH, ILLINOIS

The JAMES KNIGHTS Co.

*Any Type,  
Cut or  
Frequency*

**PRECISION CUTTERS OF QUARTZ  
FOR RADIO AND OPTICAL USES**

**Speed Working Tools**  
for Precision Operations

New and Old Workers find SPINTITE the fastest wrench for speedy assembly of small parts.

Standard sizes with hex sockets from 3/16" to 5/8". Knurled Round and Square Sockets available on special order.  
SPINTITE works like a screw driver

T51 Set in Leatherette Roll includes 7 SPINTITES 3 screw drivers and chuck type handle

**STEVENS WALDEN, INC.**  
465 SHREWSBURY STREET  
WORCESTER, MASSACHUSETTS, U. S. A.

STEVENS WALDEN TOOLS & BOXES

lar backlog of war orders on their books or enough business to keep them going for a year and a half, based on the current production rate.

There has been some reshuffling of manufacturing activities due to revised military requirements, but the overall production rate has not diminished. And according to present indications there is very little likelihood that production will be decreased.

**CONSOLES IN CANADA** are rapidly becoming victims of the war. While consoles have not been manufactured for quite awhile, they were available in substantial quantities in many cities. With, however, the increased income of the war worker and his inability to buy table model receivers, the consoles became quite popular. According to, a recent survey most stores will be unable to supply consoles the latter part of this year. There are some dealers that will be able to supply these larger type radios, but little sales effort will be made to get them off the floor.

While all plants in Canada are working on war projects only, there is a possibility that allotments of material will be made to provide for the production of table model receivers, similar to the victory type made in England.

Portable receivers have, of course, been the most tragic victims of the war, in view of the restrictions on battery production. The farmer, however, will probably be given the same consideration as the American farmer and be allowed to buy batteries for his radio, provided no other receiver is available. By the time that this data appears in print, undoubtedly the Canadian government will have authorized farm battery distribution.

Interviews with many of the large distributors in Canada seem to indicate that parts for maintenance are holding their own. Except for very rare instances, most of the replacement items needed are available. The greatest problem in repair work in Canada has its counterpart in the United States, too. And that is, manpower. It is estimated that almost two-thirds of those formerly available are now in the services. While every effort is being made to train men and women for this work, it is not possible to complete such schooling as rapidly as desired. Thus repair work is being subjected to the familiar bottleneck. Incidentally, some of the broadcasting stations have instituted repair programs similar to those of many American stations to ease this situation. Technicians in these stations have been repairing receivers and training help as rapidly as possible.

**THE WHITE-WHEELER BILL** that we discussed a few months ago, is now receiving more attention than ever, because of the Supreme Court decision providing the FCC with important powers. Various organizations including the National Association of Broadcasters are making every effort to se-

cure a prompt hearing and enactment of the bill which provides for a revision of the Communications Act.

At a recent NAB meeting, Senator Burton K. Wheeler, chairman of the Interstate Commerce Committee appeared to discuss the proposed bill. He said that every effort will be made to give serious and careful consideration to the proposed legislation.

Another proposed bill with technical aspects, that is not, however, in complete favor with the industry, is the Kilgore-Patman Bill. This bill which provides for the establishment of an office of Scientific and Technical Mobilization has been criticized by many as being inimical to the best interests of scientific and technical progress. Outstanding in this opposition is the Institute of Radio Engineers. They have adopted a resolution stating that the technical resources and particularly the radio facilities of the nation are now operating very efficiently in the war effort, and that accordingly the proposed legislation would result in utter confusion.

Still another bill which seems to be in the midst of controversy is the Bankhead Bill, calling for the expenditure of between 25 and 30-million dollars for advertising. The general feeling is that the radio industry should not accept government funds for advertising. However, if the legislation should reach the passing stage, the industry will insist that there be no discrimination between press and radio or other media of communication.

A NAB resolution stating the discrimination view was adopted recently and will be directed to the factors holding hearings on the measure.

Radio seems to have given Congress a bit of pondering to do.

**NEWS THAT WILL GLADDEN ALL AMATEURS** has been released by the FCC. They have reinstated all amateur radio operator licenses which expired on December 7, 1941 and since then. These licenses have been extended for a period of three years from the date of expiration, shown on each license. In the same order, known as General Order 115, the Commission has provided that all amateur operator licenses expiring between May 25, 1943 and December 7, 1944 will be extended for a period of three years beyond the expiration date on each license.

This new order was issued because the FCC felt that it was difficult for amateur operators who are in the armed services or engaged in war work at distant locations, to apply for timely applications for renewals. Of course these provisions do not apply to any operator who has voluntarily surrendered his license or to one whose license has been or may be suspended by FCC action. The order also does not apply to any amateur operator licensee who has failed to comply with the FCC order regarding citizenship. All stations are, of course, still prohibited from operation, but the Commission is still issuing new licenses and renewing those expiring now.

# Every RADIO Man should KNOW- ELECTRICITY!

Each book 8½x11 in.  
Handsome  
Red & Gold  
Leatherette  
Binding!

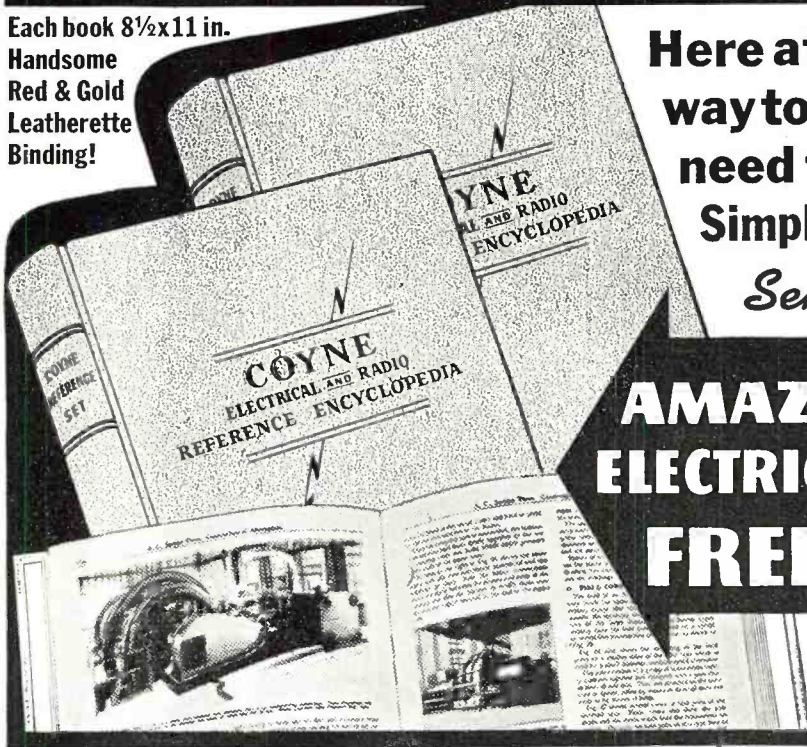

Here at last is the quick, easy way to get the knowledge you need for a real Radio future! Simple . . . practical . . . complete!

*Send coupon now for this*

## AMAZING 3 VOLUME ELECTRICAL ENCYCLOPEDIA FREE 7 DAY TRIAL

### Look Them Over in Your Own Home!

#### Electrical Knowledge is Very Necessary to the Radio Man!

Learn the basic principles of Electricity, upon which ALL RADIO IS BASED. Know electro-magnetism—circuits—wiring—motor maintenance—switchboards—batteries, etc. The Coyne Electrical Set is completely indexed. Thousands of electrical facts at your finger tips! Makes you better able to serve your country—in uniform, in your own business, in war work. Prepares you for BIGGER PAY in any line of Radio work.

#### Learn ELECTRONICS, Too!

If you're in Radio, you know the tremendous opportunities in the field of Electronics—Photo-cell—Cathode Ray—Aircraft Radio—Radio-Phonograph Servicing—Television—Electro-Therapy—High-frequency Heating—Ultra-Short-Wave Radio, etc. Electronics is vital in war. It will be the field of the future when Victory comes. Master the foundation facts with these Coyne Electrical Books. Be ready when opportunity calls. Mail the coupon today for the set so you can examine all three books for 7 days.

**44 YEARS OF  
PRACTICAL SHOP  
EXPERIENCE..  
PACKED INTO  
THIS GREAT NEW  
REFERENCE SET**

**Guaranteed by the  
Famous COYNE  
Electrical School**

Just what you've been waiting for! An easy-to-understand, practical way to learn Electricity at home—a complete, reliable Electrical Reference Set to use on your Radio job!

**AUTHORITATIVE.** Prepared by the world-famous Coyne Electrical School instructors. These men KNOW ELECTRICITY, and know how to teach it in an interesting, quick, simple way. For "beginner" or "old timer". Easy to follow—solves everyday problems. Covers everything electrical, including the subjects of Radio and Television.

#### 7 DAYS FREE TRIAL

Don't send a penny. Just mail coupon below and receive your set postpaid. Examine books for 7 days. Then if you don't agree they're the best practical electrical set you ever saw regardless of price, return the books and YOU WON'T OWE A CENT. WE PAY ALL SHIPPING CHARGES. Rush coupon now!

**H. C. LEWIS, Pres., COYNE ELECTRICAL SCHOOL**  
500 S. Paulina St. Dept. C3-T1 Chicago, Ill.

### OVER 2000 PICTURES AND DIAGRAMS OVER 1200 LARGE PAGES

This Coyne Reference Set is beautifully bound and handsomely illustrated. Printed on fine paper which brings out the illustrations and diagrams very clearly. As a result of their large page size (8x10¾") these books give you far more material than many sets containing 6 or 8 books, yet because there is less binding in 3 books we are able to sell the Coyne Set to you for far less money. You will be proud of these books and will treasure them all your life.

#### INCLUDED FREE

At this time, I am including with each Reference Set, one year's FREE Consultation Service by mail from our staff of instructors on any Radio or Electrical subject.

H. C. LEWIS, President  
COYNE ELECTRICAL SCHOOL  
500 S. Paulina St., Dept. C3-T1, Chicago, Ill.

Send me the big 3-volume NEW EDITION Coyne Electrical Reference and Instruction Encyclopedia. Within 7 days after receiving the books, I'll either return them or send you \$1.95 and then \$2 a month until the total price of \$13.95 is paid. We pay the shipping charges.

NAME.....

ADDRESS.....

CITY.....STATE.....

OCCUPATION.....AGE.....

**SAVE 10%.** Send cash price, \$12.55, with order if preferred—you save \$1.40. Same 7-day free trial and return privilege.

FASHION NOTES

# SYLVANIA SERVICEMAN SERVICE



by  
**FRANK FAX**

## SAVE YOUR SUITS — WEAR SYLVANIA WORK CLOTHES

This service coat is a knee-length, double strength herringbone-weave dungaree. Roomy pockets at arm's length. Can be buttoned far down the front to protect street clothes. Available in sizes 36, 38, 40, 42 and 44. Price each: \$1.95.



This service apron, made of heavy green duck, has three tools-and-parts pockets. Just the thing to impress customers with your efficiency and neatness. Buy several, so you'll always have a clean one. Price: only 25 cents

This service jacket is made of the same tough material as the service coat. Single-breasted, three large pockets, full-length sleeves. Just as suitable for shop wear as service calls. Available in sizes 36, 38, 40, 42 and 44. Price: \$1.75



Order from your Sylvania Jobber or direct from Frank Fax, Department RC-7, Sylvania Electric Products Inc., Emporium, Pa.

**SYLVANIA** ELECTRIC PRODUCTS INC.  
RADIO DIVISION

**THAT ORDER PROHIBITING RETAIL DELIVERY OF RADIOS** fortunately has been rescinded in part. In the original order issued by the ODT, retail dealers were prohibited from delivering radios and phonographs. The wholesale delivery of radios and phonographs was permitted with two deliveries a week, but the dealers were unable to deliver the merchandise that they had received. This fallacy has now been corrected so that twice a week deliveries of phonographs and radios are now permitted, a fortunate ruling that has eased many an economic problem. The only problem now is to get all the radios that people would like to have for delivery. That, of course, is a condition which cannot be adjusted so easily in the present emergency.

**POSTWAR PLANNING OR CRYSTAL GAZING** has been a topic of comment at conferences and meetings, from coast to coast. And as the weeks go by, the interest on this subject seems to be spreading. All the analysis indicate that we will not have receivers of *out-of-the-world* style, as soon as the war is over. As a matter of fact, quite a few months will pass before we even have receivers from any plants because of conversion problems. And receivers made then will be similar to those made when production was stopped last year. There is talk in Washington that some materials for development purposes on peace time receivers may be available next fall. An allotment of this nature will, of course, provide for an earlier return of receivers when peace time comes.

The postwar planning ideas of most manufacturers have become practical, down-to-earth arrangements. Of course, there are many problems concerning distribution and tastes that cannot be answered or predicated now. However, all surveys do show that the need for new equipment will be vast. And it will take solid management and control to achieve complete success in this postwar era.

When the developments of the present war are employed in the postwar equipment, there is no doubt that we will have receivers that will be outstanding in every respect.

**A NEW OVERALL GENERAL SCHEDULING** order known as M293 covering *critical common components* recently went into effect. In this order *test equipment* has been included. From now on, all orders for test equipment must be accompanied by a new form as PD556 which is, in effect, another version of the old PD1A. This is an application form which the prospective buyer must send to the Radio and Radar Division of WPB for approval. One copy of the form is sent to the supplier with the order.

The test equipments included in the new order are included in eight groups as follows: In the first group we have audio and radio frequency signal generators and oscillators. In the second

group are included frequency measuring equipment such as primary and secondary standards and associated measuring equipment, interpolation oscillators, heterodyne detectors, audio frequency meters, electronic frequency meters, electronic deviation meters, wavemeters and wave analyzers. In the third group are included harmonic analyzers and cathode-ray oscilloscopes. Electronic power supplies and voltage regulators (but not including variable controls) are included in the fourth section. The fifth group includes impedance bridges, wheatstone bridges, capacitance bridges, precision condensers, vacuum-tube bridges, inductance bridges, megohm bridges and megohmmeters, vacuum-tube voltmeters, electronic tube-testers, output meters, Q-meters, electronic volt ohmmeters, volt-ohm milliamperer analyzers and noise and field strength meters. The other groups include precision standards, electronic speed regulating measuring equipment, such as stroboscopic devices, and oscillograph recorders.

**AN INCREASE OF TEN PER CENT IN PRODUCTION** is now expected because of the standardization of indicating instruments for the military radio and radar. The elimination of the wide variety of meters previously used, and the substitution of comparatively few types to afford the same results as the many types used before, will provide, of course, for simplified assembly and design.

Standardization has also been put into effect in other component groups, to further assist in the increased production quotas set by the Government.

**POWERFUL AMERICAN-MADE BROADCAST** stations operating on foreign shores are now blanketing the European and Asiatic continents. The latest transmitter to go on the air over there is the 50,000-watt station located in the heart of Belgium's African empire, Leopoldville. Its broadcasts are beamed primarily at Belgium. In Brazzaville, French Equatorial Africa, another 50,000-watt station is being built. This will carry the voice of Free France, direct to France.

These new transmitters are not makeshift units, but rather modern devices with such features as temperature and humidity control, air-conditioning, etc. Incidentally, these stations are also equipped for facsimile.

**COPPER HAS BEEN PERMITTED** to come out of its shell. Conservation order known as M9C was amended to provide for the use of copper in the production of radio receivers and parts, provided the manufacture of such products was permitted under the Limitation Order L265, released early last month. This metal, heretofore, had been restricted even for the use of repair parts. With this new ruling however, the necessary copper for repair parts and essential equipment is available once more.



# RESISTORS IN THE AIR

*In the new Bendix RTA-1B two-way telephone for aircraft and ground station service, WARD LEONARD, wire wound vitreous enamel resistors are used.*

To quote from an article in March 1943 FM Magazine by Mr. R. B. Edwards, Bendix radio engineer, "Aircraft radio apparatus design might be described as the radio engineer's delight, for no restrictions are put upon the designer's ingenuity in using the best he can find in materials and methods to assure absolute dependability."

**WARD LEONARD RESISTORS** are built to withstand heat, moisture, vibration and other adverse operating conditions. The line covers a wide range of types, sizes, ratings, terminals, mountings and enclosures. Let us send you bulletins describing resistors of interest to you.



But the use of Ward Leonard Resistors is not confined to communications. You find them used by the Army, Navy and by industry for every purpose where dependable resistors are required to operate under most difficult conditions.

Ward Leonard Engineers are at the service of every manufacturer of equipment using resistors. They will gladly suggest the resistor from the Ward Leonard line that will not only give you the best possible service but will be best adapted to the conditions of assembly.

## WARD LEONARD

### RELAYS • RESISTORS • RHEOSTATS

Electric control (WL) devices since 1892.

WARD LEONARD ELECTRIC COMPANY, 47 SOUTH ST., MOUNT VERNON, NEW YORK

August, 1943

13

**COMPLETE  
CENTRALIZED  
SERVICE**  
on *Everything* in  
**RADIO AND  
ELECTRONICS**

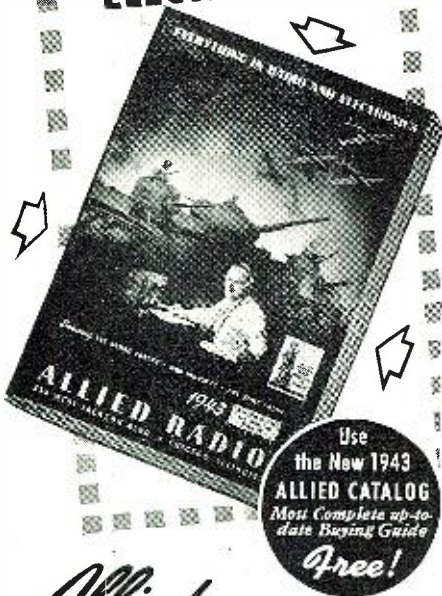

**Allied SPEEDS SUPPLIES**  
for the Armed Forces...War Industries...Home Front

ONE quick, dependable central source of supply for all your Radio and Electronic needs . . . over 10,000 items for the Armed Forces, Radio Training, Research Laboratories, War Industries, and Service Replacement. Our large complete stocks speed delivery. Our experienced staff is ready to help you.

**6 Radio Books for 75c**

Dictionary of Radio Terms. No. 37-751 <b>10c</b>	Radio Data Handbook. No. 37-754 <b>25c</b>
Radio Circuit Handbook. No. 37-753 <b>10c</b>	Radio Builders Handbook. No. 37-750 <b>10c</b>
Radio Formulas & Data Book. No. 37-752 <b>10c</b>	Simplified Radio Servicing. No. 37-755 <b>10c</b>

*Write for Quantity Prices*

ALLIED RADIO CORP., Dept. 1-H-3  
833 W. Jackson Blvd., Chicago, Ill.  
Please send following books (.....c enclosed)  
 FREE     37-750     37-752     37-754  
1943 Catalog     37-751     37-753     37-755  
 Send All Six Books

Name.....  
Address.....  
City..... State.....

**ALLIED RADIO**

**PORTABLE RADIO TRANSMITTERS** have again distinguished themselves. Recently such a transmitter was dropped from a postal command plane to 19 survivors of a ship, torpedoed in the North Atlantic. This provided the means of contacting a rescue ship. This method of contact which occurred in Canadian waters was duplicated recently in American waters, except that in the American incident, the portable equipment was a part of a life raft. These unique transmitters employ a hand-driven generator to supply power. Transmitted are distress signals on international frequencies.

To provide effective coverage, box kites supporting an antenna and held aloft by glass yarn, have been used very effectively. These strands of glass yarn have proven their worth even under the most stringent conditions. It seems as if the yarn is not affected by salt water spray or other oceanic elements. Accordingly the kite is kept aloft, without fear of breakage, even in a storm-swept sea.

The Germans also use transmitters of this type for rescue work. However, their equipment is much larger and bulkier and according to tests, less effective in both coverage and consistency of performance.

**THE MIDDLE WEST IS PLAYING** a most important role in the manufacture of military radio and detection devices, according to a WPB statement covering the *Arsenals of America*. They say that 25% of the equipment used in radio and radar comes from Region six which consists of the states of Illinois, Wisconsin, Indiana and Iowa. Contracts in this region total over a billion dollars.

**THE REPUBLIC OF MEXICO** now has a chain of thirty-six stations which will be linked to the Mutual Broadcasting System. In the new service which will soon be in operation, both short wave transmission and long line telephony methods will be employed to effect international linking. The key station in Mexico City on broadcast frequencies is XEOY and the short wave component of this station is XEOI. The chain in Mexico is known as Radio Mil.

**WIRE FAILURES STILL SEEM TO HAVE A HABIT** of occurring at the most inopportune moments. Recently, during a coast-to-coast broadcast, a wire failure between Denver and Omaha interrupted transmission to the East for over an hour. Engineers point out that although line trouble is rare its occurrences are costly events and usually difficult to control. This is particularly true in the long stretches of land in the west. The use of ultra-high-frequency relay stations, it is claimed would serve to alleviate this condition in many instances. These stations, they say, can be of the automatic, unattended type used by many facilities. In some states the police departments have used these

unattended remote transmitter systems for as long as two years, without any type of servicing. They claim that it is less expensive than the wire system and more efficient. In any event, the suggested use of these relay units further emphasizes the growing importance of ultra-high frequencies in a variety of services.

**THE PATENT OFFICE HAS ALWAYS BEEN** a lively place, and it is livelier than ever today with so many interesting issues being released. Recently, for instance, a unique radio beacon system using two non-directional antennas was patented by Frank G. Kear, a consulting engineer of Washington, D. C. This development, wherein the antennas are spaced a certain number of degrees apart, with each antenna being supplied with modulated radio-frequency energy through which the beacon system may be controlled, will be used by the Washington Institute of Technology, to whom Mr. Kear made the assignment.

A cathode-ray indicator and a loop antenna mechanism, constitute the basis of another interesting patent that has just been granted. This cathode-ray and loop unit is used in a radio direction finder, and the patent was awarded to Henri G. Gusignies of New York. During the past months the cathode-ray has been a prominent feature of many patents. It appears as if this unusual tube will become the center of a great variety of detection devices that will not only be used for location purposes, but for servicing and maintenance studies.

Two prominent men of the radio industry are also among recent patent winners. They are Dr. Ray H. Manson, who is vice-president and general manager of Stromberg-Carlson, and Albert E. Schell, an associate in the company. Their patent consists of an automatic phonograph record changer that operates with either ten- or twelve-inch records in series, or with the front and back of the records in succession. Work on this new device was started before the war. Production, of course, is being withheld until the conclusion of the present emergency.

While pouring over patent records we also ran across a patent that truly belongs to the . . . *believe-it-or-not* . . . class. According to the patent No. 877,357, Nathan Stubblefield, in 1902, developed a means of transmission of sound, music and the human voice, that appeared to be the basis of broadcasting. Experiments started in 1892, according to records. And on Decoration Day, 1902, Mr. Stubblefield held a demonstration using the equipment described in this patent and transmitting over a distance of a mile. The demonstration was made in Philadelphia between Belmont Mansion and Fairmount Park. Not only did Mr. Stubblefield win a patent in this country, but also in England and in Canada.

(Continued on page 90)

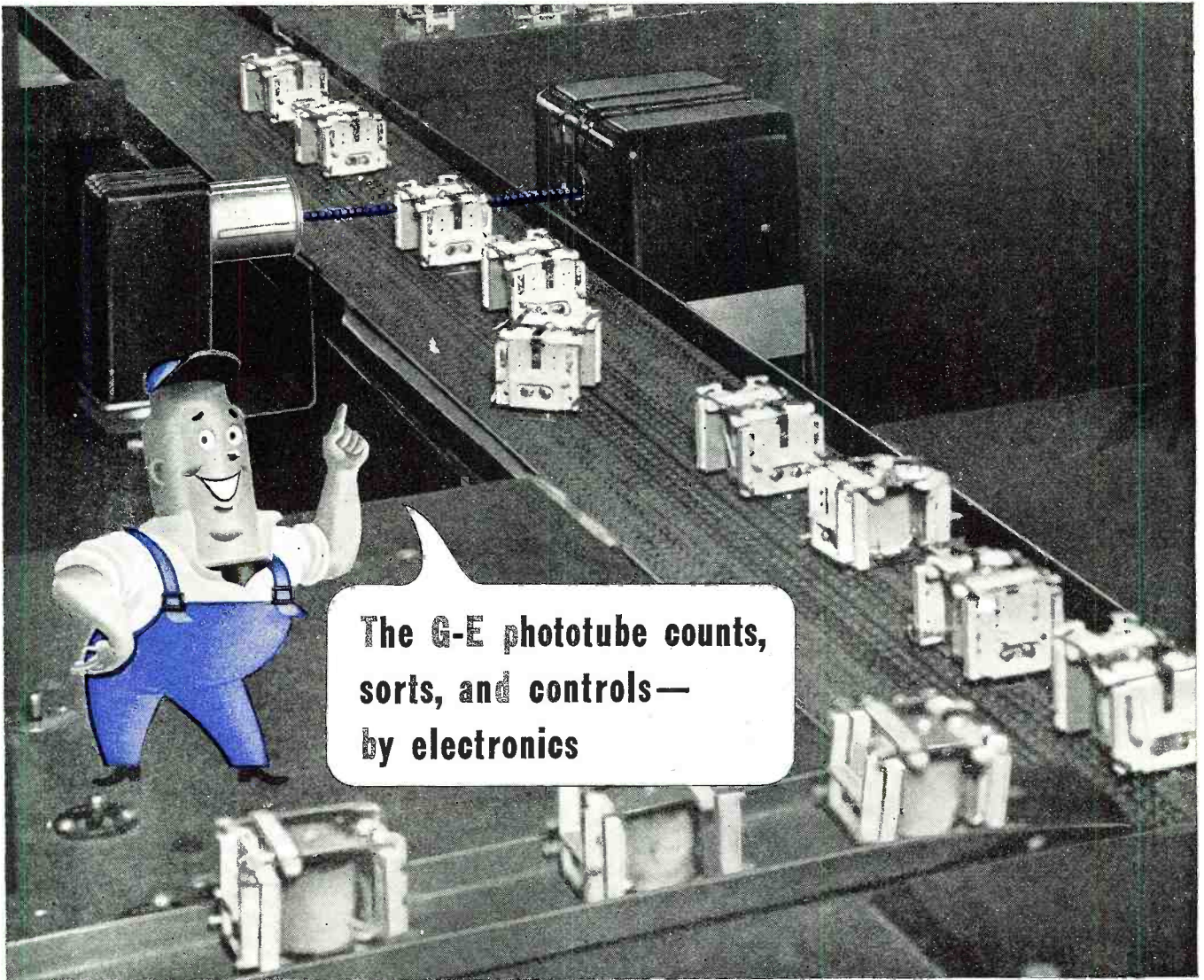

The G-E phototube counts, sorts, and controls—by electronics



The General Electric phototube, a light-sensitive electronic tube with hundreds of applications, is one of the most useful tubes in modern industry.

ONE phototube counts the relays speeding down a war production line.

Another rejects imperfect ball-bearings by automatically sizing each one to perfect dimensions. A third, responsive to radiant energy, controls temperature in an electric furnace.

A fourth watches the smoke density in a plant chimney and sounds an alarm to warn of wasteful combustion.

In its many industrial applications the phototube is primarily a signaling device, actuated by the breaking or

modulation of its beam of light. It tells other tubes what to do and when to do it.

Working with the thyatron, a precision "timer," the phototube transmits a low-power impulse which is amplified by the thyatron to such proportions that it can start or stop, accelerate or decelerate the equipment.

Thus in hundreds of ways does the phototube increase the efficiency of industry. New uses are discovered daily.

It is the purpose of G-E electronic engineers to aid *any* manufacturer of

electronic devices in the application of electronic tubes. General Electric, through its nation-wide distribution system, is also prepared to supply users with replacement tubes.

**Free booklet on electronic tubes.** Send us the names of interested men in your plant and we will keep them informed of electronic developments. For example, we will mail without charge an illustrated book entitled "How Electronic Tubes Work," written in easy and understandable language, and showing typical electronic tubes and applications. *Electronics Department, General Electric, Schenectady, N. Y.*

*Tune in "THE WORLD TODAY" and hear the news direct from the men who see it happen, every evening except Sunday at 6:45 E. W. T. over CBS. On Sunday listen to "The Hour of Charm" at 10 P. M. E. W. T. over NBC.*

**GENERAL  ELECTRIC**

162-BB-8850

General Electric employees are now purchasing over \$1,000,000 in War Bonds weekly

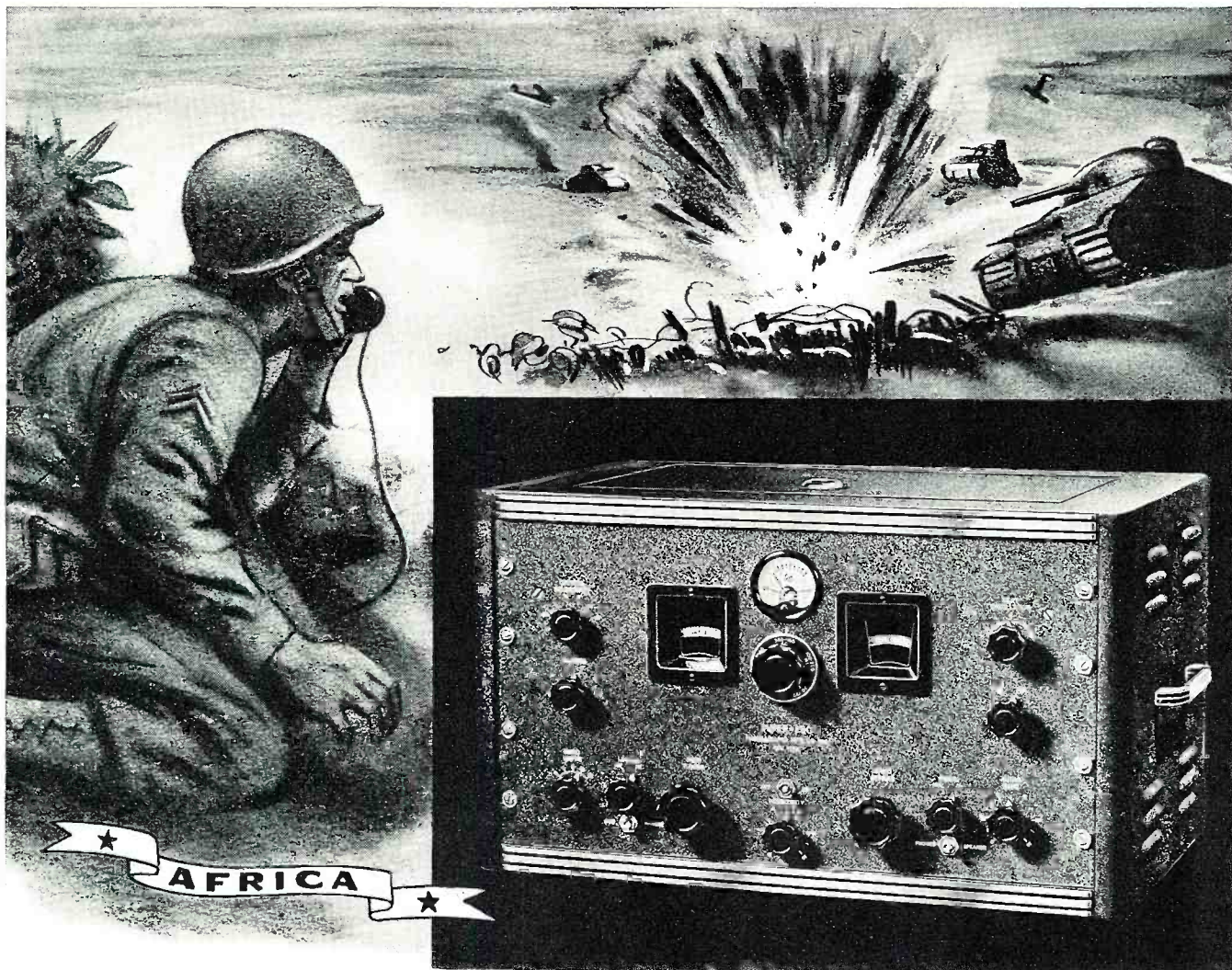

Serving on all our fighting fronts  
 . . . the **SUPER-PRO** "SERIES . 200"

THIRTY-THREE YEARS of engineering research are built into every piece of Hammarlund fighting equipment. We're proud that our equipment *came through* with our fighting men in the successful battles of Africa.

THE HAMMARLUND MFG. CO., INC.  
 460 West 34th Street, New York, N. Y.



**HAMMARLUND**



One of the Army's most valuable "weapons" is the versatile SCR-299.

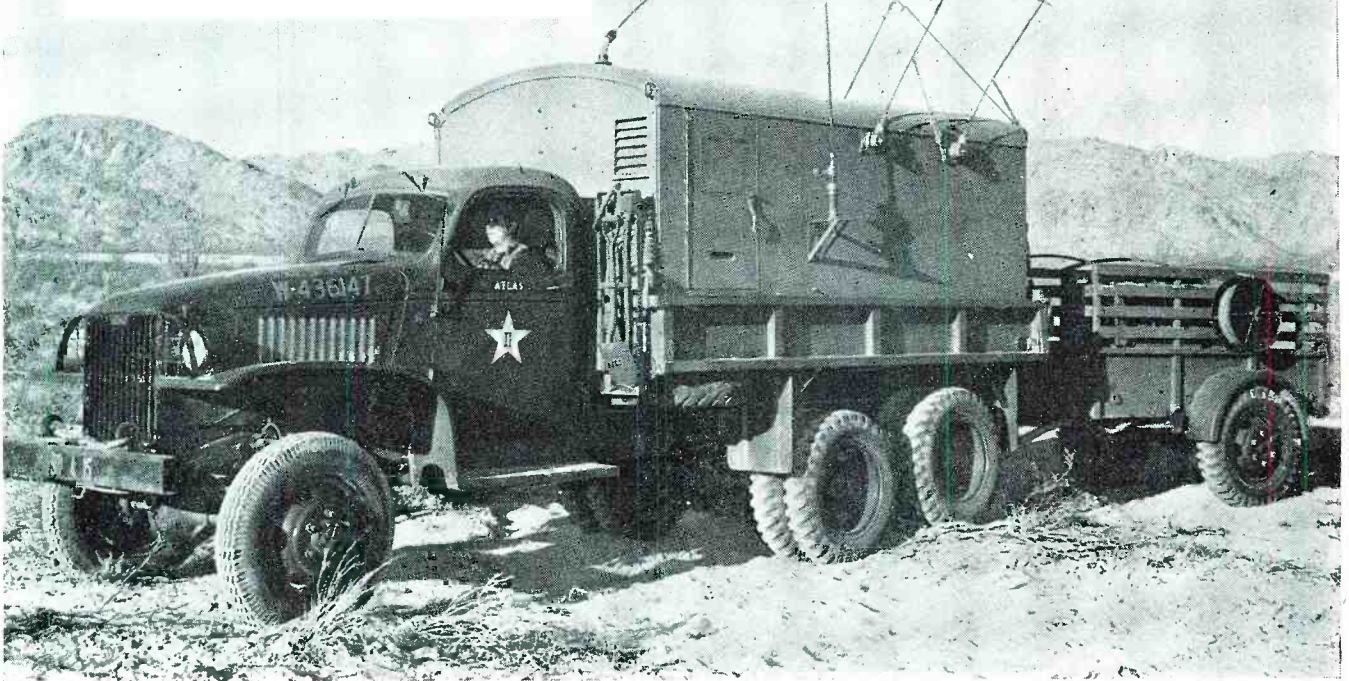

Another version of the famous 299—mounted on a 2½ ton truck.

# THE ARMY'S SCR-299

by **OLIVER READ**  
Managing Editor, RADIO NEWS

THE major contributing factors for winning a modern war include the development of secret weapons, new devices, or of an entirely new technique not possessed by our enemies. The Army, for example, has its Beaufors gun, its sensational Garand rifle, and its tiny, fast-moving Jeep. Our Air Force, with its Flying Fortresses and Liberators, has two outstanding combat weapons. The Navy, with its new radio locators and other detecting devices, has increased our defensive strength. And Signal Corps technicians in cooperation with civilian engineers have developed and produced many potent radionic weapons of war. One of the most outstanding in the latter category is the so-called SCR-299 mobile radio communications unit.

To the average layman, the Army has always followed certain development procedures and, in most cases, the final design of any particular product has been the result of out-moded techniques that had been perfectly adequate to handle any situation before modern "blitz" tactics were adopted. This story of the SCR-299 is a fine testimonial to American ingenuity and foresight, and to the Army's ability to utilize these qualities in securing their almost phenomenal successes in the "battle of communications."

Map below shows the territory over which the mobile units performed so efficiently.

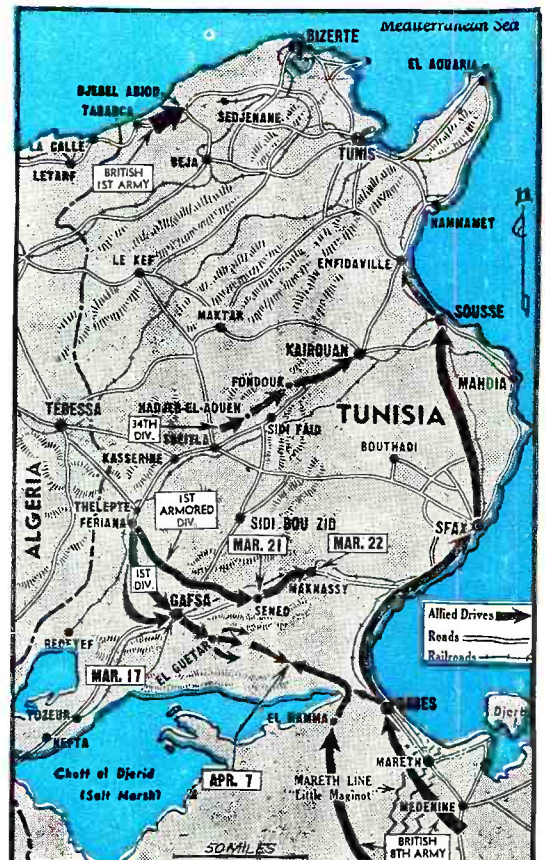

Courtesy—Chicago Tribune

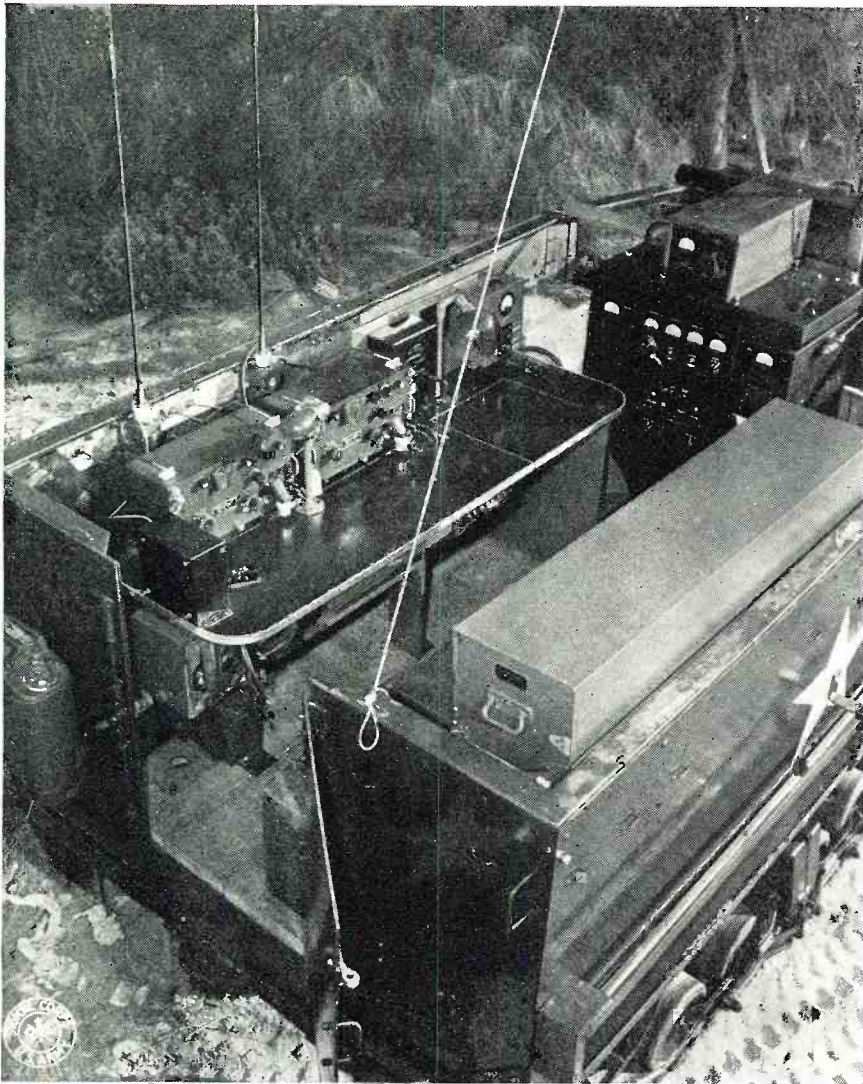

A complete high power radio transmitter and receivers mounted in an Army M-3 Half Trac personnel carrier.

Final testing of radio equipment at Signal Corps Depot before the completed unit is shipped to far-off lands.

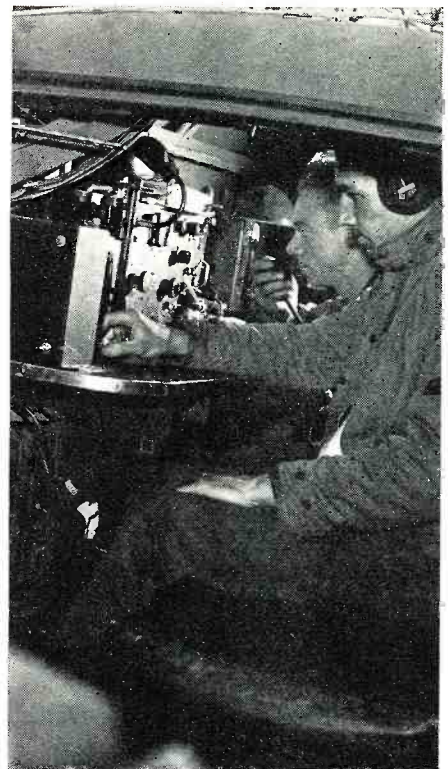
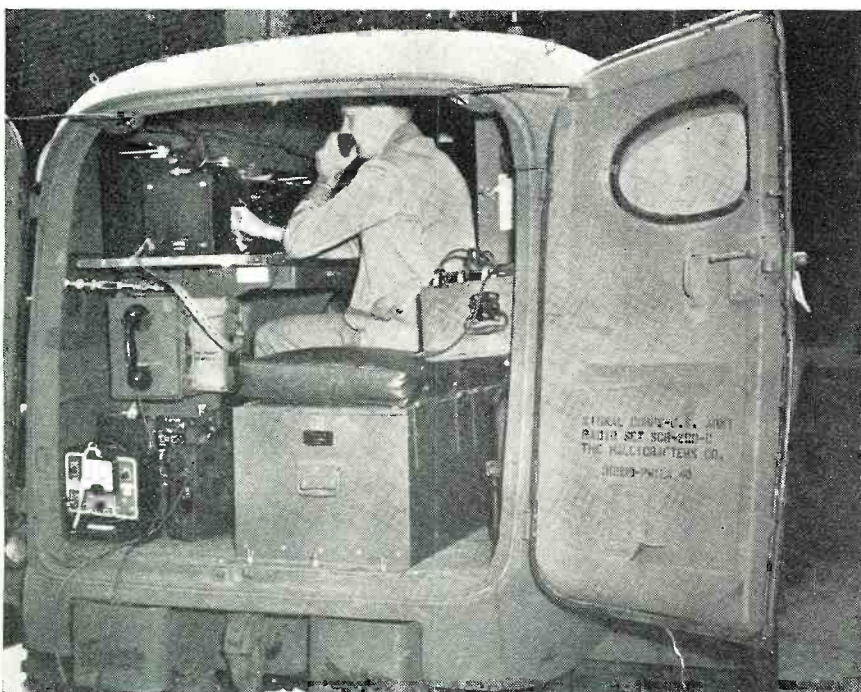

Interior of truck shows latest receivers and storage cases for spare tubes and coils.

The initial success of Germany's military machine was due largely to the rapidity in carrying out military operations and by complete coordination between all forces. Without radio communications, such lightning-like military operations would not have been possible. Modern warfare relies on speed! As the requirements for more rapid action are demanded, so, too, does the necessity for faster and more reliable communications exist. In addition, modern wars are fought with combined operations from various forces. Among these we find the ground, air, armored forces, etc. None can function effectively as a separate force. Each must rely upon the others to help gain the common objective in the shortest possible time and with a minimum loss of personnel.

American military leaders had the foresight, prior to the bombing of Pearl Harbor, to predict what was to come and to realize that the plans for more complete coordination must be carefully made so that American forces would not be left unprotected from lack of timed coordination with their supporting forces.

In order to train thousands of new troops for modern warfare, it was necessary that they be schooled in the new techniques required for fighting against those nations who had taken great pains to perfect their military machine and who had equipped their forces with new instruments of destruction.

The 1940 Louisiana Maneuvers were the "proving ground" for our Army to test out our recently adopted tactics and to find out whether or not they would be effective in combating

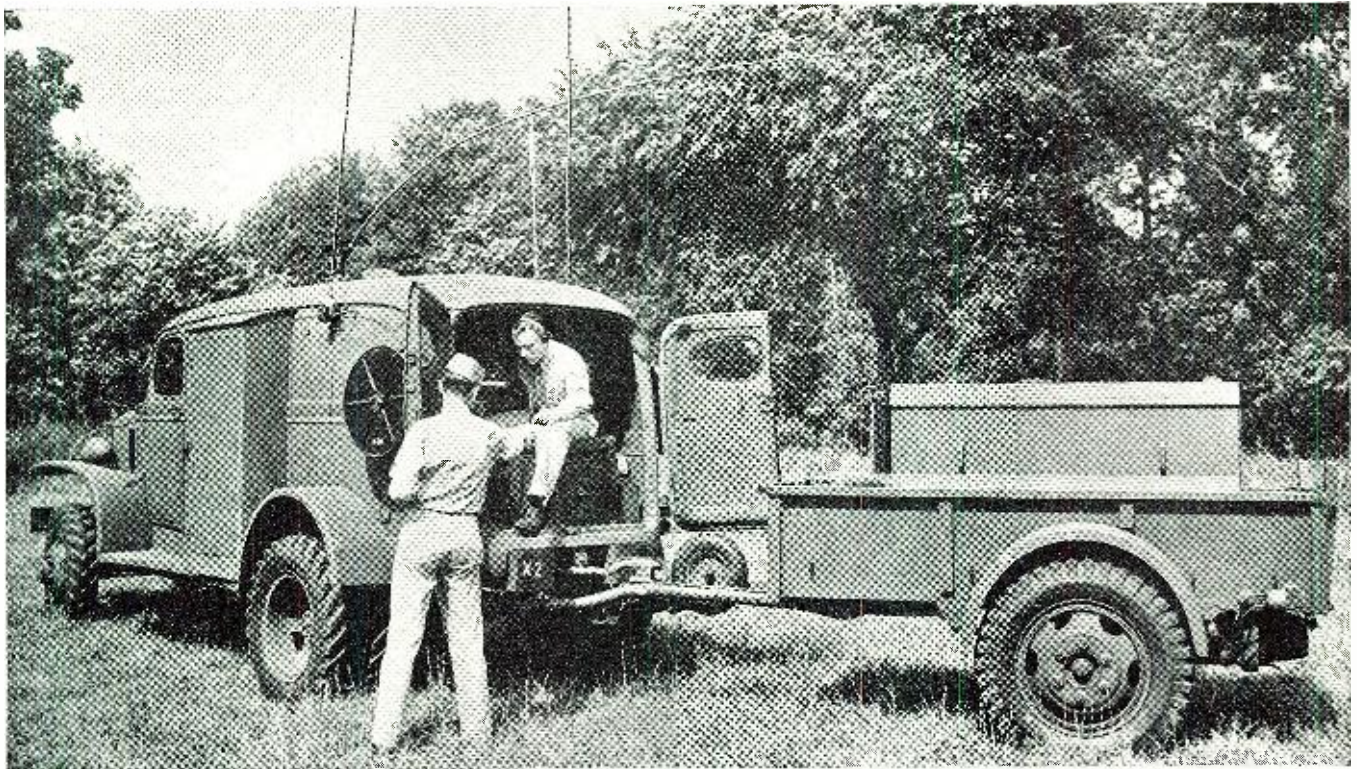

Special heavy-duty cables connect the mobile unit with the trailer that contains the gasoline-driven power unit.

our potential enemies. Incidentally, the German Army broke through the Maginot line while these maneuvers were in progress.

The "maneuvers" represented the first and extended application of long distance tactics which utilized the mobility of the newly organized armored forces. After observations by various commands, it became apparent, particularly to skilled communications men, that a radio set was urgently needed which would be capable of transmitting (by voice) up to and including 100 miles, and furthermore, that this would be required even while the fast-moving armored units were in motion at various speeds over rough roads, through woods, and over difficult terrain.

While communications in the main were adequate, it was apparent that something must be done to provide satisfactory radio communications in the new "blitz" warfare. Colonel Dawson Olmstead, Commandant, Signal Corps School, Fort Monmouth, New Jersey, who attended the 1940 maneuvers and was subsequently promoted to Major General and Chief Signal Officer, recognized the problem and proceeded to lay the plans which resulted in the development of the SCR-299. After a complete analysis of the situation, Colonel Olmstead recommended that a high-powered mobile transmitter be designed which would be fully capable of producing the desired results. He suggested, too, that little time should be spent in searching for such a unit. The problem would have to be met immediately in order that the Army be supplied with the most modern equipment that could

be developed and which would be capable of meeting the stringent demands dictated by his observations at the 1940 Louisiana Maneuvers.

Captain Frank C. Meade, War Plans and Training Division, now Brigadier General Meade, Director, Signal Troops Division, forwarded recommendations in regards to Colonel Olmstead's "dream transmitter" to the Signal Corps Board concerning the development of a set having the characteristics outlined.

A project was set up as the result and an allotment was made to cover development of the set at the General Development Laboratories in Fort Monmouth. Major General Roger B. Colton, Chief of Signal Supply Services, then Director of the General Development Laboratories, immediately gathered together a total of some 20 transmitters from various manufacturers throughout the United States. Each was given a complete technical analysis, a performance test, and other "baptisms of fire" in order to find out whether or not any one of them would offer possibilities as a basic unit from which the final model could be perfected and one which would meet all the requirements recommended by Colonel Olmstead. One of the demands upon the transmitter was that it cover a wide range of frequencies and that its components be so designed that they would operate continuously over long periods of time.

Among the many transmitters tested was the *Hallicrafters* HT-4, a 450-watt unit designed primarily for amateur communications. It packed a healthy wallop on both voice and code and its other features indicated that here was

an ideal unit to which certain refinements could be added and that with these additions, the result would be a transmitter capable of being adapted to military uses. The transmitter problem was solved! The SCR-299 also includes standard *Signal Corps* BC-342 and BC-312 receivers and type PE-95 gasoline engine driven generator made by *Onan*, together with many other components produced by American manufacturers. Radio men scattered over our world-wide fighting fronts know this set as the SCR-299, now in service wherever our troops fight.

The design of the mobile unit for housing the equipment presented some very interesting problems. Due to the heavy power requirements of the transmitter, it was necessary to provide an independent supply which would be capable of continuous operation in any climate or temperature. It was apparent immediately that a single truck would not be practical inasmuch as the gasoline-driven motorgenerator, would, of necessity, be in close proximity to the operating position which would present definite hazards to the safety of the truck's personnel. Furthermore, the mechanical noises and other disturbances generated would interfere seriously with radio communications. By designing a special trailer, it was possible to separate the two units and to distribute the weight which made for better maneuverability. By separating the two units and by connecting them with specially designed cables, it was feasible to use the SCR-299 for either a fixed station or a fast-moving mobile unit.



Generals Olmstead (center) and Meade (left) at the fighting front during the African campaign.

All units in the SCR-299 are tied down securely. Shock mountings are used to absorb mechanical vibrations and to protect delicate equipment from severe jarring which results when the truck is in motion over rough terrain.

Another problem which had to be met was that of loading up a mobile antenna at the frequencies used. There is only one practical type for use in a fast-moving vehicle; that is the "whip" antenna with its specially designed insulator. Unfortunately, there is a limit to the over-all length. Not only must it be capable of taking considerable abuse when traveling through wooded areas but its insulator and accompanying support must be able to absorb and give way to changes from its normal vertical position. The *Signal Corps* engineers de-

voted much research to the design of the supporting insulator. One of the requirements was that it withstand the full r.f. carrier power flowing to the antenna from the transmitter. Many types were tried before one was found which would stand up in any weather.

The mobile unit, in its final form, was given a very thorough test at the *Signal Corps Laboratories* before it was delivered to the Army. Its performance was remarkable! Not only would it cover the range required but considerably more. The various components stood up under severe abuse. It was now ready to join the "battle of communications!" General Olmstead's "dream" had come true!

The SCR-299 is used by our troops wherever they fight throughout the

world. The "299" is seeing service in fixed station installations and in cases of emergency have communicated successfully over a distance of 2300 miles (UHF). Not only do the American forces find this unit to be capable of giving trouble-free service on any battle front but the British as well found them so satisfactory that they asked for a large quantity on Lend Lease sometime ago. As new uses were found for the SCR-299, the demand increased. The demand exceeded the supply.

Major General Dawson Olmstead, Chief Signal Officer, and Brigadier General F. C. Meade returned recently to this country after an extended trip to many of our far-flung fighting fronts. They found that our troops had a large number of 299's.

The North African victory is now glorious history and it is significant that radio played such an important part in bringing the campaign to a successful conclusion.

The first contact of the British 8th Army and the British 1st Army during the time when General Montgomery was proceeding from El Alamein toward Tripoli and Tunis and when the 1st Army under General Alexander was coming from the West, was carried out with the SCR-299 mobile unit according to reports of personnel in that theater.

General Olmstead has said that the 299 contributed greatly during the operation of the Battle of the Kasserine Pass. At that time the American forces were being hurled back a matter of some 160 miles from the Pass in North Africa. There was considerable disorder during this retreat. Great quantities of tanks, artillery and even 299's and other equipment and material were captured by the enemy. There was urgent need at this critical time to reassemble our troops in order to make a stand against the advancing enemy. There was need for immediate reinforcements and replacement of supplies. The going was tough. Our forces, scattered over hundreds of square miles found that the only means for calling in such help was by our new radio equipment. The mobility of the SCR-299 was the answer to the problem.

Among the many observations made by General Olmstead was that the 299 had proven itself to be a highly versatile unit, capable of performing under the most unusual exigencies.

It must have been gratifying to the General to find that the set which he had originally recommended to the Army was being requested for use by the *Air Forces*. They had discovered the mobile SCR-299 to be an ideal unit for them and one capable of handling the many communications required by their personnel. It can now be told that the 299 is being used not only by our ground forces but by the *American Air Forces*, the *British*, and probably the *French*.

During his visit, General Olmstead  
(Continued on page 54)

Trailer units for the SCR-299 ready for shipment. These house the huge gasoline driven motor generators.

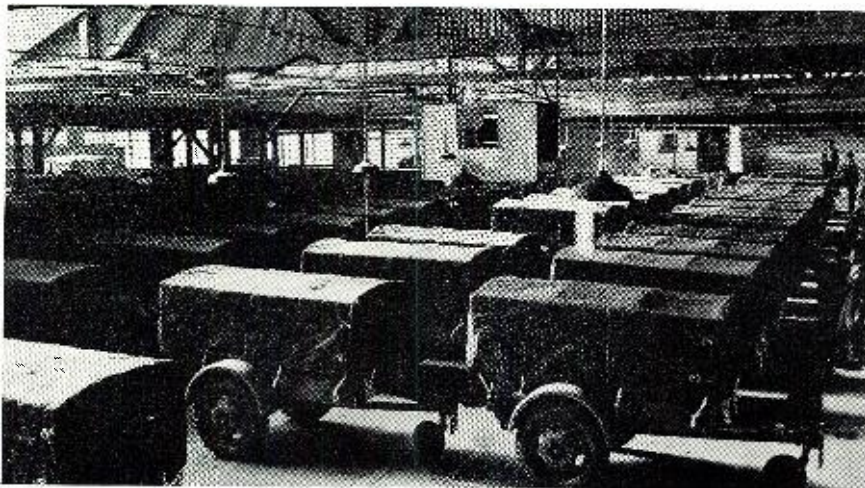

# Wide Band Amplifier Design

by **EDWARD J. BUKSTEIN**

*The design of wide-band television amplifiers, covering a frequency range from 50 cycles to 5 megacycles.*

FOR television applications and for other purposes which are today classified as military information, circuits are employed which will amplify uniformly a wide band of frequencies. The television amplifier, or video amplifier as it is often called, must fulfill two primary qualifications

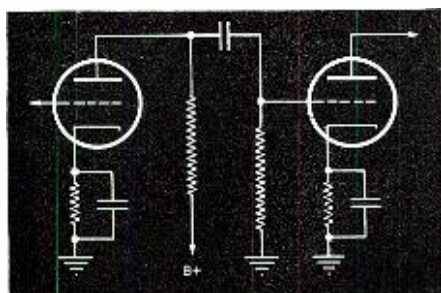

Fig. 1. Resistance-coupled amplifier.

not considered in the ordinary audio frequency amplifier. First, it must have a favorable gain characteristic for frequencies ranging from as low as 30 cycles per second up to four or five megacycles. The second requirement for the video amplifier is that it introduce no phase distortion. In an audio amplifier phase shift is relatively unimportant because the human ear is incapable of detecting it in the amounts present.

In the video amplifier, however, phase shift must be both dealt with and restricted, since phase distortion of the signal will result in a distorted image on the television screen. The time delay of the video amplifier must, therefore, be either zero or a constant over the entire range of its amplification. To understand fully the design considerations encountered in the video amplifier, one must first acquaint himself with the operation and shortcomings of the conventional resistance-coupled amplifier shown in Fig. 1.

For purposes of simplification of calculation, the circuit of Fig. 1 may be

Fig. 2. Equivalent circuit.

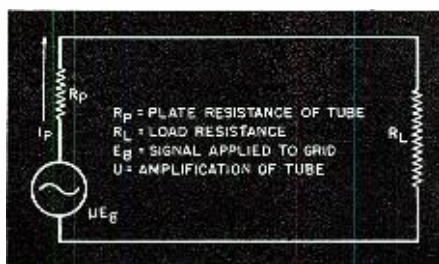

resolved into the equivalent circuit shown in Fig. 2. The tube here has been replaced by a generator developing a voltage of  $\mu e_g$  and having an internal resistance of  $R_p$ . The voltage developed by the generator causes a current,  $i_p$ , to flow through the circuit consisting of  $R_p$  and  $R_L$  in series. The value of the current,  $i_p$ , may be calculated by simple Ohm's law:  $I = E/R$ . The  $E$  in this case being  $\mu e_g$ , and  $R$  being  $R_p$  plus  $R_L$  in series.

Therefore, the current flow in the circuit of Fig. 2 is

$$i_p = \frac{\mu e_g}{R_p + R_L}$$

The voltage developed across the load resistance,  $R_L$ , is the calculation of most importance, since it is this voltage which is applied to the grid of the next stage. The voltage developed across  $R_L$  may be determined by again resorting to Ohm's law. The voltage is equal to current ( $i_p$ ) times the resistance ( $R_L$ ). Multiplying  $R_L$  by the equation already derived for  $i_p$ :

$$\text{Voltage across load} = E_{R_L} = \frac{\mu e_g R_L}{R_p + R_L}$$

It is often advisable to rearrange this equation by dividing both the numerator and denominator by  $R_p$ :

$$E_{R_L} = \frac{\mu e_g}{R_p} \cdot \frac{R_p R_L}{R_p + R_L}$$

Since  $\frac{\mu}{R_p} = G_m$  or transconductance of the tube

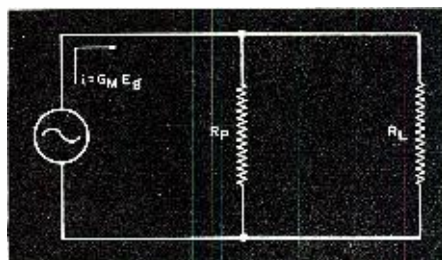

Fig. 3. Constant-current version of Fig. 1.

Then:

$$E_{R_L} = G_m e_g \frac{R_p R_L}{R_p + R_L}$$

The calculations made thus far are based upon the equivalent circuit of Fig. 2. This equivalent circuit is known as the constant-voltage generator type and is most useful in making calculations where triodes are used. When pentodes are employed, however, another type of equivalent circuit is best suited to calculation.

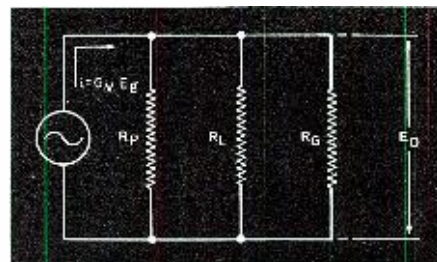

Fig. 4. Mid-band equivalent circuit.

This is the constant-current generator type and is shown in Fig. 3.

In this circuit the tube has been replaced by a generator which causes a current,  $G_m e_g$ , to flow through the plate resistance and the load resistance in parallel.

The action of an amplifier varies with frequency; therefore, to completely understand the operation of the amplifier, one must study its behavior in the different frequency ranges. These frequency ranges are divided into three groups: low frequency, intermediate frequency, and high frequency.

The equivalent circuit of an amplifier operating in the intermediate frequency range is shown in Fig. 4.

The plate resistance ( $R_p$ ), the load resistance ( $R_L$ ), and the grid resistance of the following stage ( $R_g$ ) are paralleled across the generator supplying the current ( $G_m e_g$ ). The amplified output voltage of the stage is  $e_o$ .

At the low frequencies the reactance of the coupling condenser increases and becomes appreciable. It must, therefore, be considered in the circuit analysis as shown in Fig. 5.

It is the reactance of the coupling condenser,  $C_c$ , which limits the low frequency response of the amplifier.

In the high frequency range, the reactance of  $C_c$  is very small and is therefore negligible. However, at the high frequencies, the shunt capacity

Fig. 5. Equivalent circuit for low-freq.

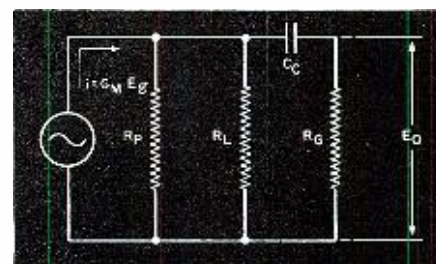

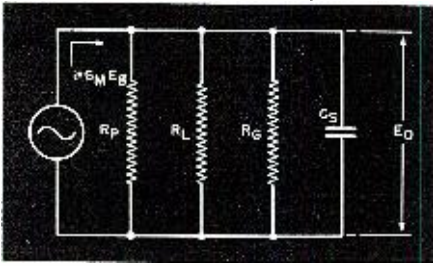

Fig. 6. Equivalent circuit for high-freq.

of the circuit must be considered (Fig. 6). This shunt capacity,  $C_s$ , is the sum of three individual capacities: the output capacity of the tube, the circuit wiring capacity, and the input capacity of the following tube. The reactance of  $C_s$  becomes very small at the high frequencies, and since it is shunted across the circuit that is in parallel with  $R_p$ ,  $R_L$  and  $R_G$ , it tends to decrease the response at high fre-

quencies, in the amplifier stage. Thus amplification is sacrificed to obtain a uniform frequency characteristic.

It can be proven mathematically that the amplifier's response, towards the higher frequency end, will be essentially flat (within 3 db.) up to frequencies of four or five megacycles if the following conditions exist. The value of the load resistor,  $R_L$ , should be equal to the reactance of the total shunt capacity at the highest frequency desired. The second requirement is that the inductive reactance,  $X_L$ , should be equal to one half of the load resistance,  $R_L$ .

Let us then proceed to design an amplifier to have a flat response up to five megacycles. Keep in mind that to obtain these results,  $R_L$  must equal  $X_{Cs}$  and that  $X_L$  should be equal to one half of  $R_L$ .

Suppose we design our amplifier us-

half of  $R_L$  or 490 ohms. Working back from the formula

$$X_L = 6.28 f L$$

$$490 = 6.28 \cdot 5 \cdot 10^6 L$$

$$L = \frac{490}{6.28 \cdot 5 \cdot 10^6} = 15.6 \text{ microhenries.}$$

∴ 15.6 microhenries is the value of inductance required.

The gain of this stage may be calculated from the formula

$$\text{gain} = G_m R_L,$$

where  $G_m$  is the mutual conductance of the tube. In this case 9000 micromhos.

$$\text{gain} = 9000 \cdot 10^{-6} \cdot 980 = 8.82$$

The loss of gain in an amplifier at low frequencies is caused by the increased reactance of the coupling condenser. Why not increase the capacity of this condenser then? The answer is that the capacity is limited by the maximum allowable leakage which is inherent in larger condensers.

To compensate for these losses, the value of the load impedance into which the tube works, must be increased at the lower frequencies. The method of doing this is illustrated in Figure 8. The reactance of  $C_r$  is increased with a decrease in frequency.

The conditions which must exist in order that the amplifier's response shall be flat to the lowest desired frequency are as follows. The reactance of  $C_r$  should be one-tenth or less of the value of  $R_r$ . Secondly, the values of the two time constants  $R_L C_r$  and  $C_r R_s$  should be equal.

To design the amplifier to have a flat response down to 50 cycles, we first decide upon a value for  $R_r$ . Assume 5000 ohms. Knowing that the

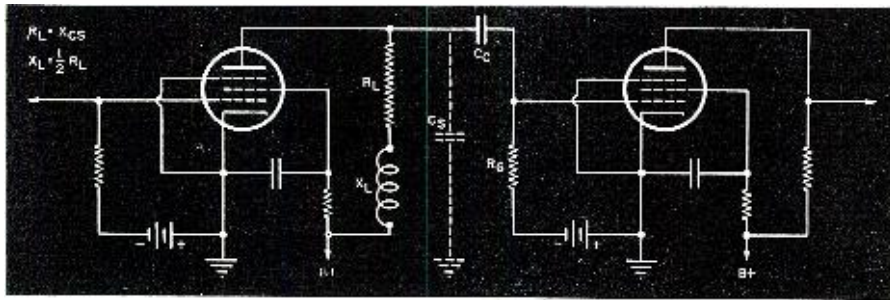

Fig. 7. Amplifier circuit diagram compensated for high frequencies.

ing a 6AC7 tube followed by a 6AG7. These tubes are television pentodes having high transconductances.

First we must calculate the value of the total shunt capacity of the circuit. The tube manual shows the output capacity of the 6AC7 to be  $5 \mu\text{mfd}$ . The input capacity of the 6AG7 is  $12.5 \mu\text{mfd}$ . We can estimate the value of the stray capacity of the wiring to be about  $15 \mu\text{mfd}$ . Since these three capacities are in parallel across the circuit they are additive and their sum is  $32.5 \mu\text{mfd}$ . By employment of the formula for capacitive reactance,

$$X_c = \frac{1}{6.28 f C}$$

we find the reactance at five megacycles to be 980 ohms. Since the desirable condition is that  $R_L$  should equal this value of reactance, we know that  $R_L$  should be 980 ohms.

The second condition is that the inductive reactance,  $X_L$  should equal one

ten times the value of the plate load resistor used is usually quite small (less than 2500 ohms). By using this small value of load resistance, the gain at the intermediate frequencies is brought

up to the level of the high frequency gain. Thus amplification is sacrificed to obtain a uniform frequency characteristic.

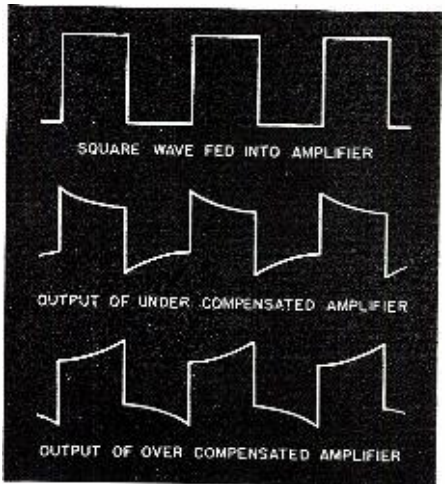
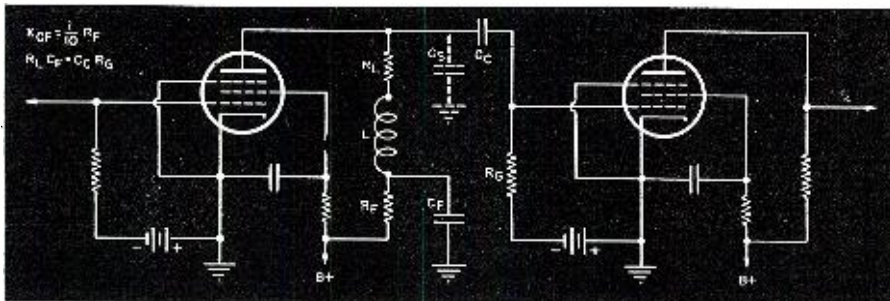

Fig. 9. Wave form for various compensations.

Fig. 8. Circuit diagram of an amplifier compensated for the low-frequency drop.



reactance of  $C_r$  should be one-tenth of 5000 ohms at 50 cycles, we work back in the formula

$$X_c = \frac{1}{6.28 f C}$$

$$500 = \frac{1}{6.28 \cdot 50 \cdot C}$$

$$C = \frac{1}{6.28 \cdot 50 \cdot 500} = 6.37 \mu\text{mfd.}$$

6.37  $\mu\text{mfd}$ . is the value for  $C_r$  to give a flat response down to 50 cycles.

The second condition required is  
(Continued on page 93)

# AIR-RAID Alarm Circuits

by  
**WILLARD D. STEWART**

*Alert alarms are vital for the protection of many of our coastal regions. Herein described are several proven designs used for civilian defense.*

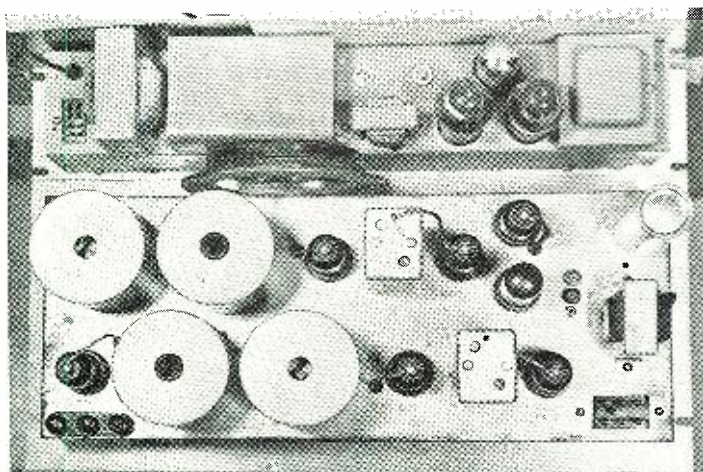

Top view of the Missouri State Highway Police alarm unit.

**S**INCE it is necessary to activate countless areas for air-raid warnings practically instantaneously, a swift medium of notification must be used. In radio, we have one of these lightning means of contact.

It has become the duty, therefore, of many types of transmitting stations, to maintain a constant listening watch for such warnings. Since it is impossible for the central air raid information supply source to reach all of these stations at once, a linking or network system must be used. Stations with wide coverage are used as key stations. These key units transmit a warning tone, when so notified. It is these warning tones that the other stations pick up, that completes the cycle of notification, and alerts the area. Since these notes, transmitted on the key station frequency, may come at any time, the listening-in post station must provide a constant watch. This can be done by either of two ways: a crew of operators or an automatic listener-in.

Many stations have selected the automatic operator or listener-in method, for it has proven not only to be very efficient, but a man-power saver. And both of these features are certainly essential today. While the automatic operator or listener-in takes many forms or circuits, its basic mode of operation is the same. For it is linked to the receiver and tuned to the key station frequency constantly. When the tone is picked up, an alarm is activated. Then the wheels of the air-raid warning service start flashing around.

The circuits used in these air raid alarms have a variety of interesting features of design. Incidentally, although these systems have been adopted for use in listening-in post stations, they can be applied to the receivers in the home, too.

Now, let us take a look at some of these circuits. All circuits have a basic purpose, as we mentioned previously. That is, they must respond to the warning tone. That means that none but the frequency of this tone must alert or actuate the circuit. It is in the means of actuating that most of the circuit variance exists.

In the unusually simple, yet effective alarm system, developed by Lieutenant Arthur H. Vickerson and Sergeant Robert L. Gray of the Boston Police, we find many interesting features. Relays are, of course, essential units in most alarm devices. We say most, for there are some that do not use the relay. This will be discussed later. In those alarms that do use the relay, the contacts of a relay may be connected to the output of a receiver. The contacts of this relay may then be made to energize the field of a second relay, using the voltage obtained from the "B" supply of the receiver. Across the winding of this second relay can be placed a large electrolytic condenser and resistor in series with each other. Then the contacts of this second relay can be used to turn on a speaker or a bell.

We obtain this result (Fig. 1A) because the normal output of a receiver is not continuous. Instead it varies according to modulation. Therefore the first relay has an opportunity to frequently come to rest on its back contact, recharging the condenser across the second relay. This, in turn, causes the armature of the second relay to remain energized, until a sustained tone arrives, which keeps the first relay from recharging the large condenser. Then the condenser discharges slowly through the resistor and the field of the second relay drops, releasing the armature which then

Panel layout of the fixed-tuned receiver and alarm system of the Missouri State Police.

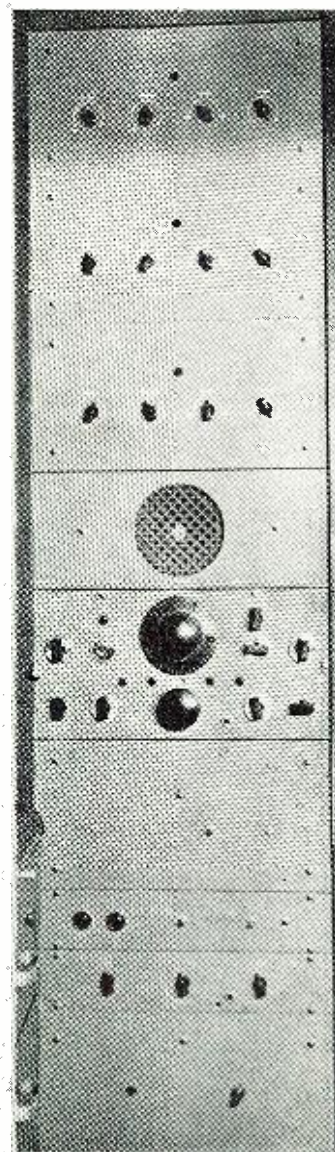

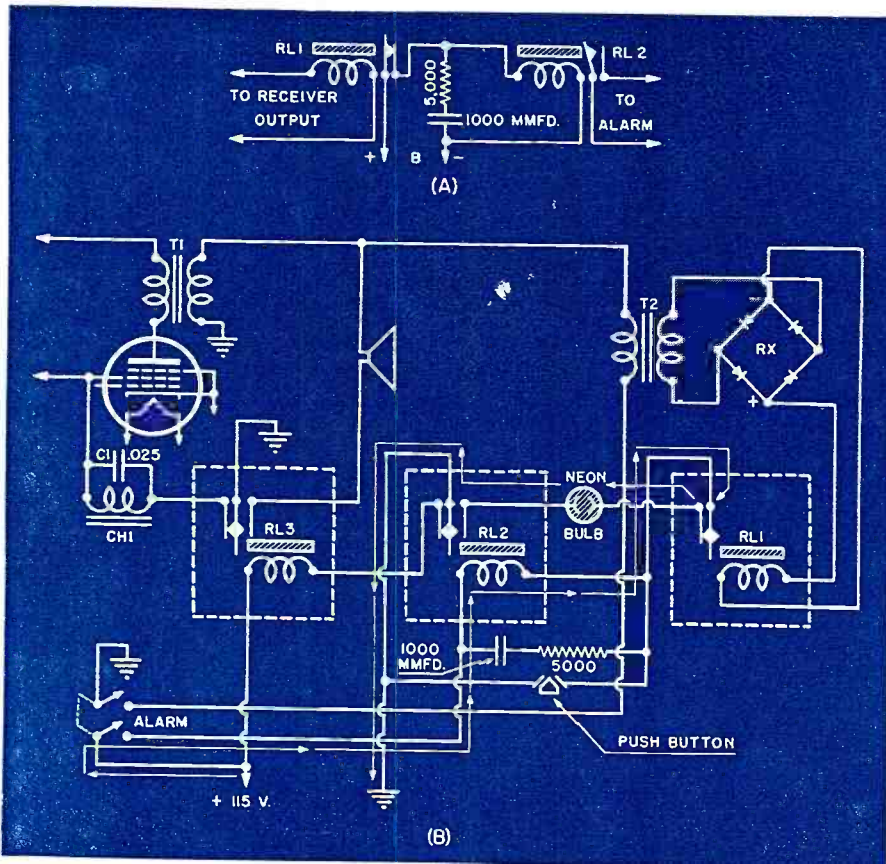

Fig. 1. The Vickerson-Gray alarm system with its basic circuit shown at the top.

closes the alarm circuit. The time period is determined by the capacity of the condenser and the resistor in series with the resistance of the field of the second relay. This condenser has an action which is similar to that of a storage battery. For circuit diagram refer to Figure 1(A).

It is necessary in actual practice to use the proper relays and the correct value of resistors and condensers, and in addition, arrange them so that

maximum efficiency results. For, for instance, to obtain sufficient voltage to operate the first relay in the Vickerson-Gray system shown in Figure 1 (B), it was necessary to insert a step-up transformer T2, which is a plate-to-5-ohm voice coil transformer. And, instead of connecting it as usual, it was connected in reverse. To make the operation of this relay consistent, rectification was used. This was done by rectifying the output of the step-

up transformer by means of a rectox unit. In this instance, this unit was obtained from an old battery charger.

The next problem concerned the exact frequency to which the circuit would respond. Thus it was necessary to devise a filter consisting of the audio choke Ch1 and condenser C1. In parallel with each other, they are connected to the screen grid of the output tube and to ground through the back contact of relay RL3. This relay is energized from the "B" supply of the receiver through the back contact of relay RL2. When the relay RL3 is de-energized, the filter combination is inserted or becomes activated. And all frequencies other than the warning tone are bypassed to ground. When the relay RL3 becomes actuated, the filter combination becomes inoperative, and the speaker is reinstated in the circuit through the front contact of the relay RL3.

To insure positive operation a 1/4 watt neon lamp signal method is used. For, for instance, the neon will flicker when the warning tone is in the receiver output. In this way, it is possible to know when the receiver volume is high enough to insure positive operation and not too high to cause false alarms. The neon lamp is inserted in series with the energizing current being fed to the relay RL2. To reset the relay following receipt of an alarm, the push-button is used.

RL1 is a 2000 ohm relay; RL2 is a 5000 ohm relay and RL3 can be any type.

In this system, the warning tone is heard in the speaker. Thus it is necessary to turn the volume up so that it will be heard. That is why the neon lamp system is so important.

The system developed by Sergeant J. W. Bryant of the radio division of the Missouri State Highway Patrol, is somewhat along the lines of Vickerson-Gray system. In this alarm, the rectified audio operated relay is used to short the bias on the trigger tube, with the bias voltage being supplied by a 6H6 rectifying the 110 a.c. voltage. When the relay No. 1 is held open by a fifteen-second warning tone, the bias is permitted by the time delay circuit, to build up on the grid of the thyatron and cut off the plate current. Any sustained tone of less than fifteen seconds in length will permit the armature of this relay to drop back against the back contact, short the time delay condenser and force the time delay circuit to start from the beginning on the next tone (Fig. 2).

Through the time delay circuit (the 2 μfd.-7 megohm section), the ten or fifteen volts of bias supplied by the 6H6, is applied to the grid of the 2051 tube. When the back contact of the relay No. 1 is held open fifteen seconds, the bias builds up sufficiently to block the 2051 and the armature of the relay No. 2 is released. This disconnects the audio filter, connecting the speaker and breaking the plate feed to the 2051. By operating the push button, voltage is applied to the

Fig. 2. The alarm system developed by J. W. Bryant as used by the Missouri State Police.

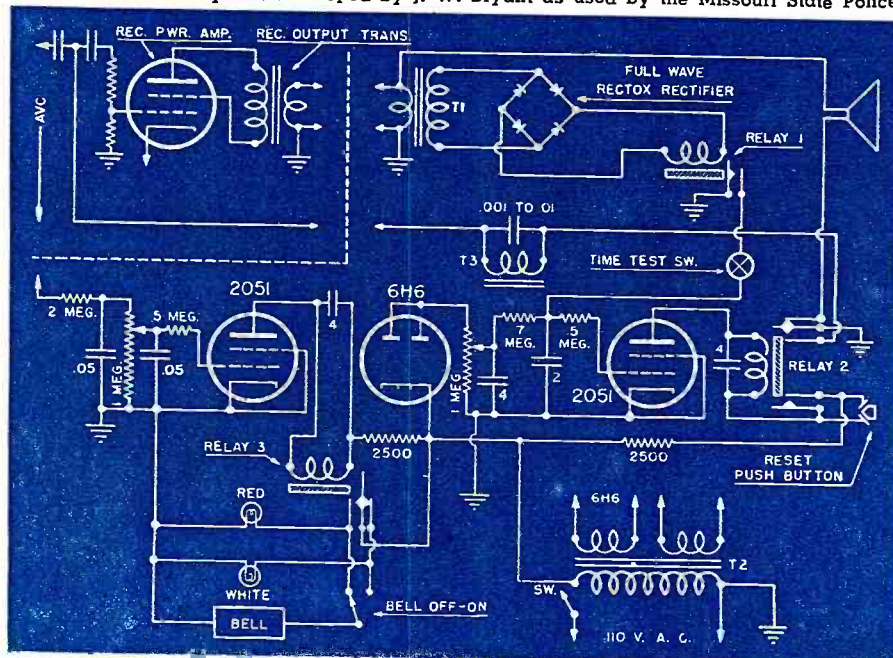





# THE SAGA OF THE VACUUM TUBE

by **GERALD F. J. TYNE**

Research Engineer, N. Y.

## Part 5. The era of controversy between patent rights on thermionic tubes designed by de Forest, Fleming, Weagant and others.

**A**FTER the first applications of the valve to the rectification of high frequency oscillations, Fleming began to study their characteristics in detail. Some of the valves had filaments of tungsten. He determined the characteristics of the valves with varying plate potential, this plate potential being supplied by a separate battery which had its negative terminal connected to the negative terminal of the filament. He found that the curves were different with different filaments and different degrees of vacua. Analysis of the curves so obtained suggested to him another means of using the valve as a detector. If the plate potential could be adjusted to cause the valve to operate on the bottom bend of this characteristic, then the superimposed signal oscillation would produce a large change in the mean current through the vacuous space. This would mean an increase in the sensitiveness of the device as a detector.

Fleming applied on June 25, 1908, for a British patent on the use of an oscillation valve with a tungsten filament, and showed such a valve with the filament operated from a high voltage battery, using a large series resistance, and the plate potential adjustable by means of a potentiometer to obtain operation on the bend in the characteristic. The complete specification of this patent was accepted on April 15, 1909 and a corresponding United States patent was obtained in 1910.<sup>112</sup> (See Figure 28.)

This same bend in the characteristic had been shown by Fleming in his February, 1905, paper before the Royal Society, but no application of this phenomena was mentioned until the application for the above-mentioned British patent was filed. It is interesting to note that this application is equivalent to that described in de Forest's paper on the two-electrode Audion published in October, 1906, a year and a half before. The difference between them lay in the fact that de Forest used a separate battery to supply the plate potential, whereas Flem-

J. A. FLEMING  
INVENTOR FOR DETECTING ELECTRIC OSCILLATIONS  
964,619. Patented Apr. 12, 1910.

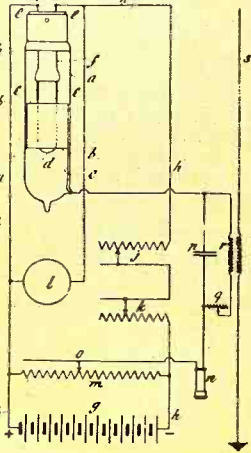

### UNITED STATES PATENT OFFICE.

JOHN ARTHUR FLEMING OF LONDON, ENGLAND, ASSIGNOR TO MARCONI WIRELESS TELEGRAPH COMPANY OF AMERICA, OF NEW YORK, N. Y., A CORPORATION OF NEW JERSEY.

INVENTOR FOR DETECTING ELECTRIC OSCILLATIONS  
964,619. Specification of Letters Patent. Patented Apr. 12, 1910.  
Application filed January 1, 1908. Serial No. 679,666.

To all whom it may concern:  
I do hereby certify that JOHN ARTHUR FLEMING, the inventor of the above-entitled invention, residing at 1, Grosvenor Gardens, London, England, has invented new and useful improvements in Instruments for Detecting Electric Oscillations, of which the following is a specification.  
My invention has reference to that type of electrical oscillation detector described by me in the United States patent specification No. 848,411 dated 10th September 1907.  
In this specification I described an oscillation valve or glow lamp, detector, which consists of an electric glow lamp of the ordinary type, but having within the glass bulb a metal plate or cylinder curved on an inclined terminal and connected through the glass.  
When the filament is rendered incandescent by an electric current, it emits negative ions or corpuscles of electrons, and these cause the residual gas in the bulb, and give in the space a unidirectional conductivity by which negative electricity can pass from the hot filament to the cold insulated plate or cylinder within the bulb, but not in the opposite direction. I employed this device as an electric wave detector in radiotelegraphy by connecting the insulated plate or cylinder to one terminal of an oscillation transformer connected to the receiving circuit of the radiotelegraphic apparatus, and the other terminal of this oscillation transformer was connected through a potentiometer or telephone receiver to the negative terminal of the filament.  
I have discovered that many experiments that I made in various forms and particularly in a form in which it comprises a filament in a glow lamp in highly efficient for this purpose show the amount of negative electricity emitted at the highest possible working temperature may be from five to twenty times as great as that emitted by carbon in an ordinary carbon filament. I am unable to explain the reason of this as positively; it is not merely that a tungsten filament can be raised to a higher temperature than a carbon filament, for metals with an oxidation which are almost analogous to tungsten, and which can be raised to an equally high temperature are not more val-

Figure 28.

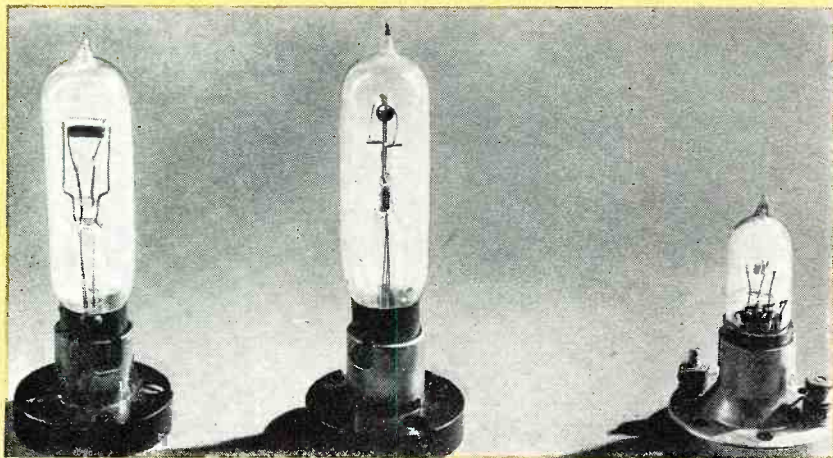

Figure 29.

ing obtained the corresponding potentials by means of a potentiometer arrangement on the higher voltage filament battery.

Somewhat later, in a paper<sup>133</sup> by Dr. R. S. Willows and Mr. S. E. Hill, there were described experimental Fleming valves in which a Wehnelt oxide-coated cathode was used. Trouble was experienced in these valves with loss of coating from the heating wires. It is not known to the author whether or not any such tubes were ever used commercially.

In the court contest in the United States over the Fleming valve and the de Forest Audion, the attorneys for the Marconi Wireless Telegraph Company of America (the assignees of Fleming's U.S. patents) found it necessary, in order to make the patent stick, to disavow certain of the rectifier claims made in the original specification which were not limited to high frequency applications.

This was necessary because in the use of a thermionic device as a rectifier, the Fleming utilization was anticipated by the Wehnelt valve. Within these limitations the Fleming utilization patent for wireless detection was basic. In a practical sense it contributed little, if anything, to wireless telegraphy of that time. It was less sensitive than other known forms of detector, such as the electrolytic and crystal types, and never came into general use. What usefulness it might have had was soon overshadowed by the development of an electronic device of increased sensitiveness, the de Forest Audion, the first practical three electrode thermionic tube, which will be treated at length subsequently.

The Fleming valve enjoyed a brief revival during the early days of broadcasting in the United States, after the expiration of the Fleming patent. A number of types of diode were put on the market in this country at that time. Examples of these tubes are the "Dietzen Vacuum Tube,"<sup>134</sup> the "Electrad Diode,"<sup>135</sup> and the "Margo Detector,"<sup>136</sup> the latter two of which are shown in Figure 29. They had a rather short vogue, since they could neither regenerate nor amplify.

The development of the de Forest Audion led to a long and bitter controversy between Fleming and de Forest, and finally resulted in the famous Marconi-de Forest patent suit, of which more later.

While this suit was still unsettled the American Marconi Company, probably motivated by a desire to have available an alternative device in case the decision in the suit was unfavorable to them, began the development of a new tube. This work was done under the guidance of the late Roy A. Weagant, who was at that time chief engineer of the Marconi Wireless Telegraph Company of America. Weagant used a Fleming valve type tube and endeavored to obtain control of the electron stream by means of a third electrode which was placed outside of

(Continued on page 72)

UNITED STATES PATENT OFFICE

ROY A. WEAGANT, OF ROSELLE, NEW JERSEY, ASSIGNOR TO MARCONI WIRELESS TELEGRAPH COMPANY OF AMERICA, OF NEW YORK, N. Y., A CORPORATION OF NEW JERSEY.

WIRELESS SIGNALING APPARATUS

1,289,981. Received Dec. 31, 1918. Patented Dec. 31, 1919.

1,289,981.

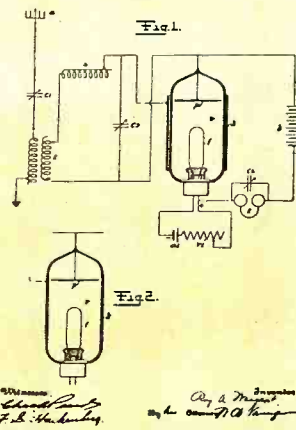

To all whom it may concern: Be it known that I, Roy A. Weagant, of Roselle, county of Union, State of New Jersey, have invented certain new and useful Improvements in Wireless Signaling Apparatus, of which the following is a specification.

This invention relates to apparatus for use in radio communication and is subject to the prior art of electrical insulation or variations.

The invention is an improvement on the well-known Fleming vacuum valve shown and described in U. S. Patent No. 1,065,800, November 25th, 1913. In the improved apparatus shown and described here, there is employed a vacuum chamber, a hot filament and a cold electrode, and outside the chamber an element having a curved, cup-shaped area in close proximity to the outer surface of the chamber, preferably a metal, as copper, is electrically connected to the outer surface of the valve chamber in any case this outer member is preferably fixed in position and arranged with its surface area parallel with respect to the path of electrons in the vacuum chamber, coming from the hot filament at one end, toward the cold filament at the other end, the hot and cold filaments being fixed at opposite ends of the chamber. The space between said interior filament is extended and the outer element is arranged so as to form a shield around the space between the interior filament. The object is to establish an extensive and intimate relation between the path of the electrons and the surface of the outer element. In the form shown the apparatus is adapted for use as a detector of electrical oscillations in connection with a telephone receiver, and in addition the filament circuit is electrically connected with the valve and the telephone equipment.

Figure 1 shows the valve and its electrical connections used as a detector. Figure 2 shows the outer electrode electrically connected on the outer surface of the valve.

The vacuum chamber consists of an evacuated glass vessel and contains the filament electrode *f* at one end and the plate electrode *p* at the other end. These are fixed at some distance apart so as to leave an open space between them. Outside the

vacuum chamber *v*, is a plate of metal *z* it is fixed in position close to the exterior surface of the chamber and is preferably a coating of copper, as shown in Fig. 2; the extent of this outer element is preferably sufficient to span the space separating the hot filament electrode *f*, and *p* and includes both said electrodes. The hot filament electrode *f*, is heated by battery *B*, the number of cells of battery *B* and the resistance *r*, being varied to regulate the heat. There is a battery *E*, connected as in the drawings, here by varying the number of cells in series, included in circuit with a telephone or indicating device *t*; a variable condenser *C* is in circuit in parallel with telephone or the terminals of this device are connected, respectively to the two electrodes *f* and *p* in valve chamber *v*. The antenna wire in the detector circuit is connected to the secondary circuit *S*, a small oscillating circuit provided with tuning elements such as inductance *L* and variable condenser *C*, one terminal of this circuit is connected to plate electrode *p* and the first downlead lead circuit, the other terminal is connected to the outside element *z*. When the surface of the outside element is disposed parallel to the electron stream between the interior electrode as described above, it follows that the field of force of the outside element when charged is at an angle to the electron stream.

The valve as equipped as a detector is made adjustable as respects adjustment and more particularly as respects response to receive impulses. The valve described above operates in connection with a telephone receiver or indicating circuit, and can be used for this purpose, as well as for wireless telegraphy and telephony.

The main terminal *z* I prefer to designate as an outside electrode element. I use this designation to define a terminal such as the one shown at *z* disposed outside the chamber, and so connected in the manner of a terminal in the circuit, outside the vacuum chamber, and an electrode in the sense of the term to be applied or detected.

What I claim is:

1. In combination, an evacuated container comprising an interior source of electrons, 119

Figure 30.

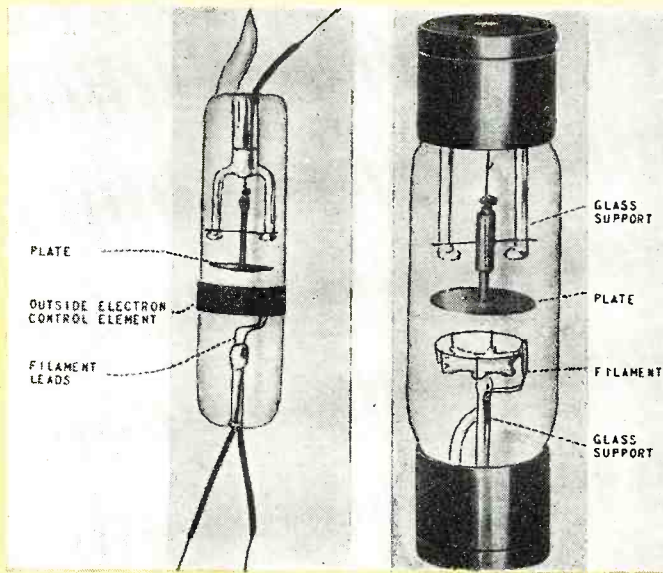

Figure 31.

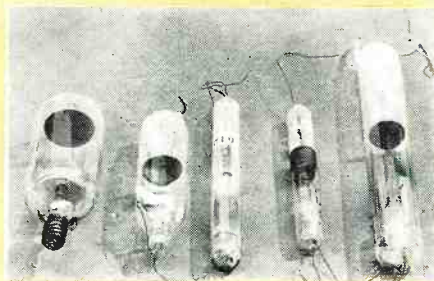

Figure 32.

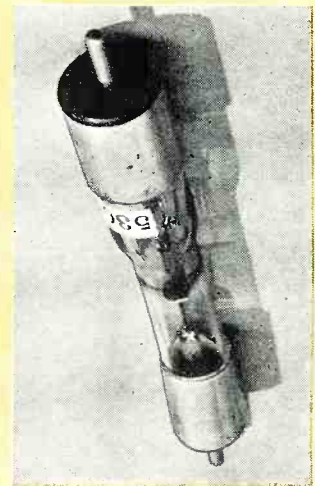
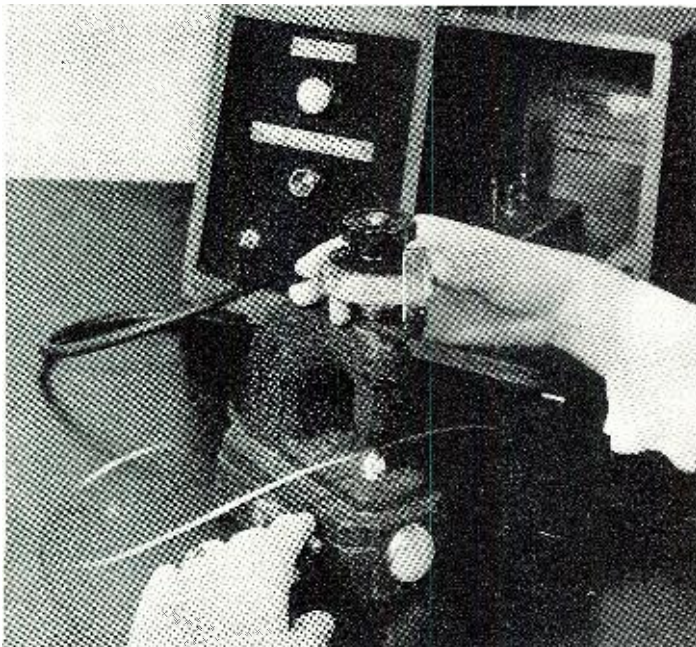

Figure 33.

# Electronic Measurements

by **CLARK E. JACKSON**

*A resumé of circuits and devices for accurate and dependable electronic measurements in the industrial field.*



An electronic micrometer for checking thicknesses to .0001 inches.

**W**HEN the scientific and industrial history of the twentieth century is written at some remote future date, one of the gleaming jewels of that saga will be the application of electronic devices to industry. Of this we may feel quite certain, since the introduction of finer tools has repeatedly marked the end of one industrial age and the beginning of a new era.

Aside from providing a variety of control mechanisms for production machinery and safety devices for machine operators, *electronics* has contributed an imposing group of measuring instruments which, in some cases at least, have already supplanted time-honored mechanical gauges. The march of applied science continues, in-

of delicacy and short-lived dependability. With increased ability to duplicate readings and to provide close accuracy under various stringent conditions of operation, however, electronic measuring instruments have become more firmly entrenched on many fronts.

High speeds of operation, surpassing the best of human records, have been attained by certain electronic indicators, and at the same time these devices have frequently proven themselves dependable and instantly available when needed.

Volumes have already been written on industrial electronic equipment. The number of available devices has been increased several fold in recent years. The country's patent literature abounds in information of this sort. Nor has the general public been neglected in the dissemination of this information. The man on the street, thanks to his liberal press, now knows that the edges of his razor blades may be inspected electronically with greater accuracy and speed than was possible with various mechanical gauges formerly employed for the purpose, although he may not comprehend exactly how it is done.

A few of these measurements are representative of those now being made in industries other than radio by means of electronic equipment. These, in turn, point to still other applications of the same methods and serve to stimulate productive imagination. Some of these measurements will be reviewed in this article, strictly from the informational point of view. Fur-

ther, exhaustive data (technical or practical) on each topic may be obtained directly from various textbooks that may be purchased today.

## Temperature

The measurement of small temperature changes has long been a task assigned to the amplifier type of vacuum-tube voltmeter. Many temperature changes, hitherto not detectable with common thermometers or measurable only with very elaborate thermal apparatus, are now determined by this instrument.

Figure 1 shows a circuit arrangement for the measurement of minute temperature changes. The sensitive element is a thermocouple which is placed in contact with the device whose temperature is to be measured or is located within the space to be checked. Small changes in temperatures generate small currents in the thermocouple which are then amplified, by means of a high-gain d.c. amplifier, to actuate an electronic voltmeter.

There are several leading advantages of this arrangement for temperature indication: the amplifier

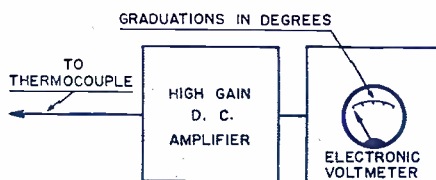

Fig. 1. Temperature measurements.

dicating that ensuing developments will place many silent sentinels of accuracy along our production lines.

Electronic measuring instruments have been compelled to prove themselves to severe critics. This is partly because a great deal of this equipment has been fashioned around electron tubes and similar devices which, in industrial circles, have long suffered a reputation, undeserved in recent years,

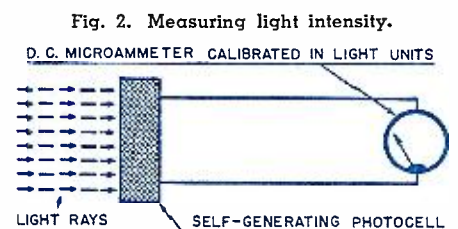

Fig. 2. Measuring light intensity.

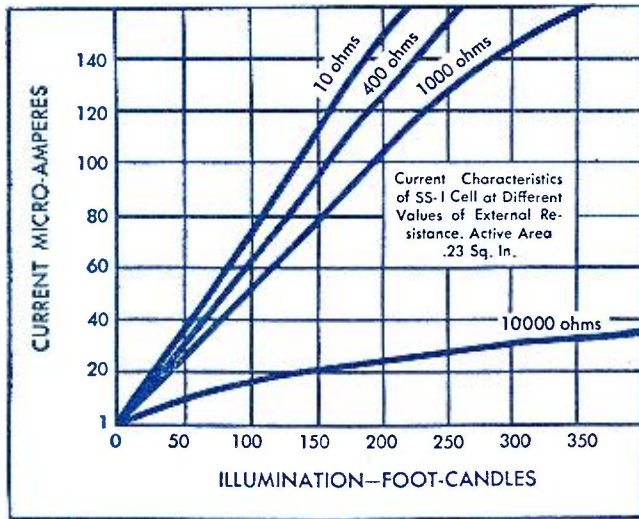

Figure 3.

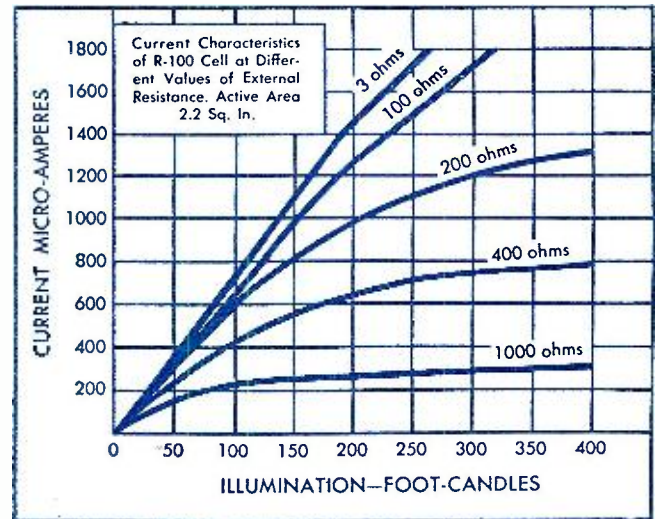

Figure 4.

permits the use of a voltage response meter with fairly high deflection values, thereby removing the instability and relative slowness of high-sensitivity galvanometers which might be actuated directly by the thermocouple. By its nature, the electronic voltmeter may be set to zero in the presence of an initial thermocouple current, a feature which permits this meter (the scale of which may be graduated directly in temperature units) to read *temperature differences*, starting either from room temperature or any initial instantaneous temperature level within the zero-set range of the voltmeter circuit. Also, there is no lag in indications, the instrument circuit responding instantly to variations in thermocouple temperature.

Considerable latitude in design is possible in the arrangement shown in Figure 1. For example, the design of the d.c. amplifier may be any of the conventional, well-known layouts for this stage of the instrument. Likewise, the electronic voltmeter circuit may be chosen in accordance with individual requirements from any one of the many suitable circuits now available. The entire set-up frequently is a combination of a standard d.c. amplifier connected to a standard, manufactured electronic voltmeter of suitable voltage range.

Similar arrangements have been employed in industry both to measure small temperature changes, small values of temperature, and to provide highly-sensitive thermostatic control. In certain chemical and biological laboratory processes, temperature changes amounting to a few hundredths of a degree are readily detected. Also, in electrical and physical research, instruments similar to the system shown in Figure 1 have found full acceptance.

When higher temperatures are to be measured, the amplifier gain may be reduced proportionately. When very high temperatures are to be measured, the amplifier may be dispensed with entirely, the electronic voltmeter serving as an indicator with high input impedance. An obvious ad-

vantage in the latter application is the fact that the temperature indicator may be placed at a considerable distance from the point of actual measurement, making it possible to maintain a constant watch from a remote point. An example of this application is the monitoring of temperature at a central supervisory point, of the furnace or oven temperature levels at particular internal points.

#### Illumination

Measurements of the actual amount of illumination generated by certain devices or materials, or of the illumination present at a particular point are of value in numerous instances. For example: illumination in correct amounts is essential to worker efficiency and eye health, and in determining the efficiency of lamps, reflectors, and other optical devices. The amount of light given off by certain materials is, likewise, a good indicator of the progress of certain processes.

For such measurements, there are available light meters of various types; illumination meters, color meters, foot-candle meters, exposure meters, etc. For simple, direct measurements, the simple light meter takes the form illustrated in Figure 2. In this arrangement, a self-generating photocell is connected directly to a sensitive d.c. microammeter so that currents generated by the action of light upon the cell will cause meter deflections proportional to the amount of light. The meter scale may accord-

ingly be calibrated and graduated directly in light units to provide a direct-reading illumination instrument. This arrangement is employed in the popular exposure meters.

Although a self-generating cell is indicated, and this type of unit will provide the utmost in simplicity and portability, any other type of photocell might be employed if means are provided for supplying the polarizing voltages required by other types.

The meter sensitivity and its calibration in illumination units will be governed by the current output of the photocell employed. A calibration curve showing current output values obtained with a manufactured self-generating cell working into various circuit resistances is given in Figure 3. From these curves, it may be seen that a photocell of the dimensions given will produce a full-scale deflection of approximately 190 foot-candles when it operates (as shown in Figure 2) directly into a 0-100 d.c. microammeter with approximately 1000 ohms meter resistance. Other foot-candle values may be marked off on the meter scale according to corresponding current values, in accordance with the curve.

When it is desirable to employ an indicating meter having a higher current deflection at full-scale, a larger capacity cell may be employed. This arrangement will also permit the measurement of higher values of illumination, as shown by the curve of

(Continued on page 46)

Fig. 5. Beat-frequency oscillator adapted for use in measuring thicknesses of material.

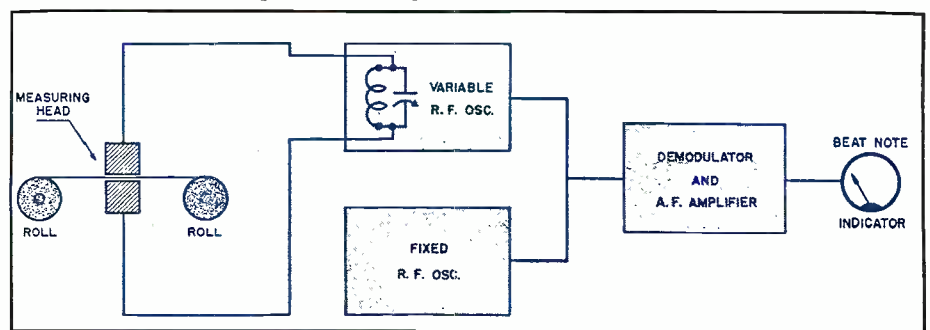



Grading of eggs is an important operation in that industry. Electrically controlled equipment automatically sorts them as to size and quality.

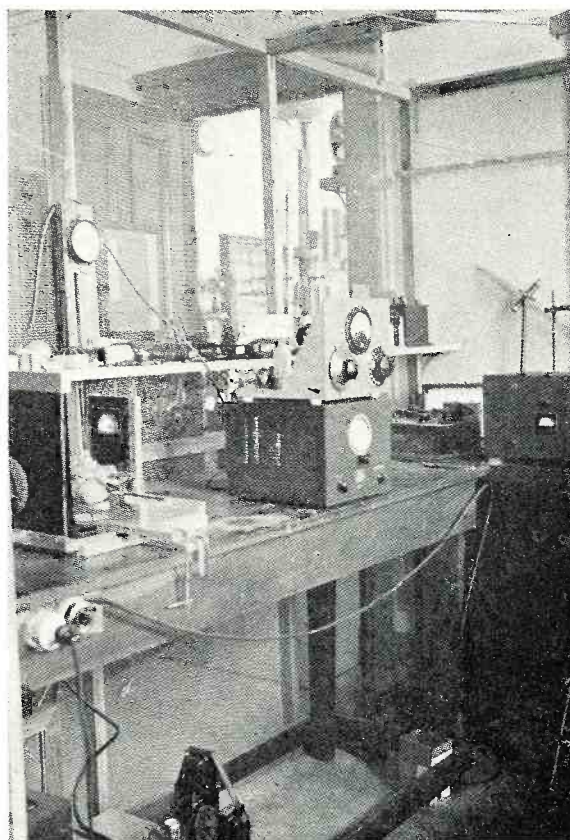

New radionic egg tester in use in the Laboratory of Experimental Embryology, Cornell University.



An electronically controlled trap, with light as bait, reduces the number of tobacco destroying insects in a warehouse.

# SCIENTIFIC

by S. R. WINTERS

**T**HE importance of radionics on the farm is proving to be a vital factor in supplying sufficient food to our many war fronts, not to mention the civilians of our Allied nations. There is an extreme shortage of manpower on the farms today, and radionic engineers, coping with these problems, have made available numerous devices as aids to agriculture. Many of these devices are not new, as it was originally intended to devise some means to aid the farmer in eliminating many of his daily monotonous chores. However, with the advancement of scientific knowledge has come new and more elaborate equipment so that ultimate vitamin content and maximum quantity of all agricultural products can be obtained.

Perhaps the greatest contribution that radionics has made to the farmer has been in the many devices which contribute to a saving in manpower.

Photoelectric lighting control for yard and barn lights automatically operates when daylight falls below the desired level.

Automatic operation of poultry houses, whereby lights are turned on at prearranged times to stimulate laying of more eggs, is an accomplished fact. Doors are opened when it is desired to allow the chickens to leave the hen house for food and exercise.

The dairy barn can be equipped with a germicidal lamp, for destroying airborne bacteria. Screens charged with



Through the use of electric heaters and electronically controlled lighting systems, an increase in egg production has been obtained.

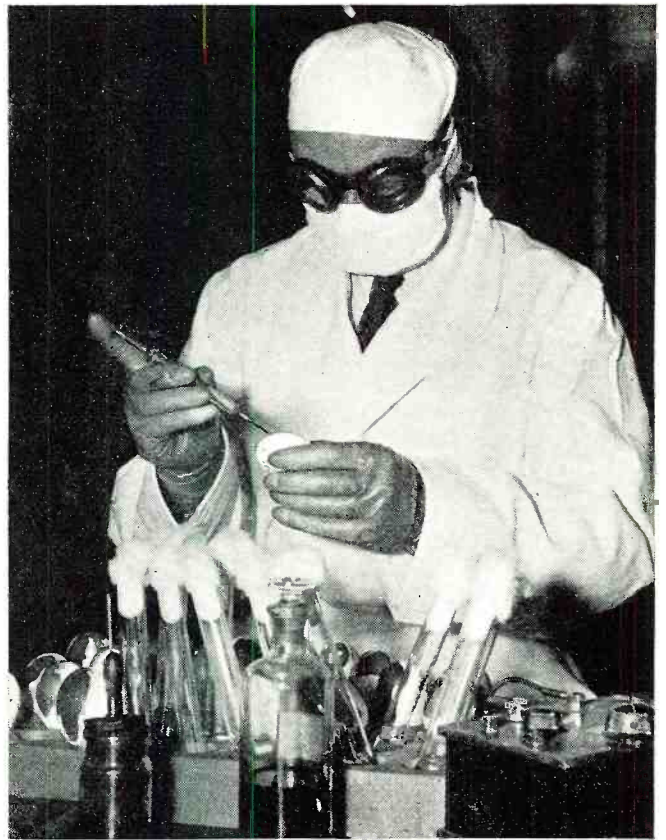

Electronic microscope makes it possible to study animal diseases. The live 10-day-old embryos are used in place of laboratory animals.

# FARMING . . .

**The advent of radionic devices has made possible the vital increases in quantity and quality of food production.**

electricity, for destroying flies and other insects before they enter the milking quarters, are available.

Sterilization of milk bottles by means of ultra violet light has proven very successful. In the past, hot water solutions and germ destroying chemicals have been used, but when the bottles are rinsed with water from municipal sources, much bacteria remains; although harmless, they cause milk to sour. Intended primarily for dairy farmers, this "sterilamp" may be adapted to bottling operations in the manufacture of soft drinks, canning plants, and in the production of drugs.

From the above it can readily be seen that a great saving in manpower is resulting from the use of these radionic aids to the farmer—a saving that will no doubt continue to grow as more and more of these devices are made available.

Equally as important as the manpower problem is that of increasing production. In this field also, radionics is playing a great part.

Much progress has been made in perfecting the use of X-rays for improving strains of plants and fruit trees. Experiments carried out at General Electric Co., using X-rays at 1,000,000 volts, have been undertaken with apple trees, berry bushes, tomato seeds, and string beans, to determine the genetic effect of electrons on growing things.

*(Continued on page 70)*

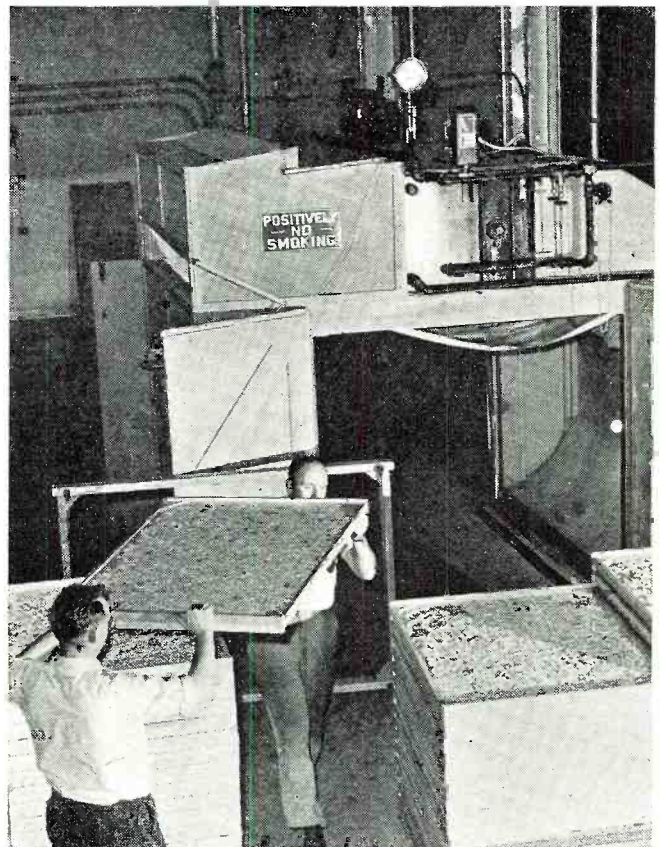

Blanched shredded cabbage, ready to be run through the dryer. Dehydrated fruits and vegetables are more compact for shipment.

# DELAY AND TIMING CIRCUITS

By **RUFUS P. TURNER**

Consulting Engineer, RADIO NEWS

**Practical data on electronic systems for time-delay and timing operations, presenting fundamental theory and applications.**

ALL present indications are that electronic devices will play a star role in the post-war world. Several well-known agencies have been at work for more than two years acquainting the general public with the wonders of modern electronics. And already, a large amount of non-radio tube equipment has graduated from the mere gadget class to find worth-while application today. Both the civilian technician and the military radio specialist will do well to learn everything possible about these things to come, in order to fit more securely into the peacetime technical picture.

This magazine has long followed the

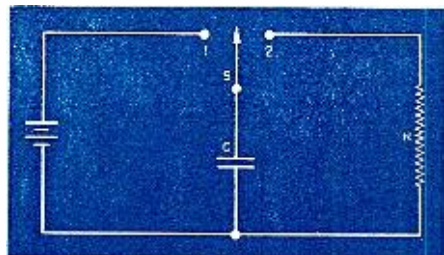

Figure 1.

avowed purpose of offering circuits and data to clarify the subject of electronics. This service, which has been carried on for the benefit of the enterprising technician, is extended this month to include delay and timing circuits.

These circuits make it possible to obtain delayed action of electrical or mechanical devices at predetermined instants, to control instruments or machinery over prescheduled time intervals, repetitious operation at selected rates, interval timing in a number of machines and devices, and many similar operations. While space does not

Figure 2.

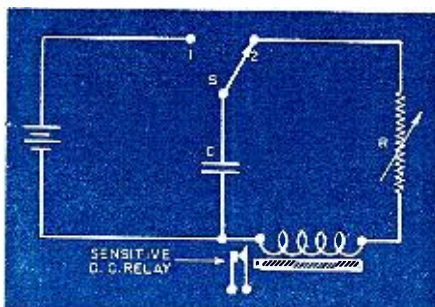
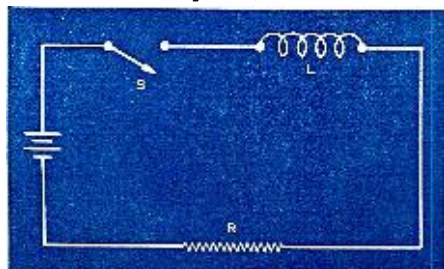

Figure 3.

permit the explanation of all the practical systems which are in present use, the rudiments of the most efficient delay and timing systems will be explained and a selected group of circuits described.

### Development

Prior to the introduction of electronic equipment, delay and timing actions of various sorts were obtained by means of mechanical devices. Most of the latter systems were based upon clockwork or motor-driven mechanisms. And, while some of them were highly successful and are still to be found in use, almost none of these arrangements was simple or inexpensive, and only high initial cost and continued maintenance could guarantee stability of operation.

In electronic delay and timing equipment, on the other hand, absence of moving parts in the actual timing mechanism precludes wear, sticking, and mechanical breakdown. And at the same time, the detrimental effects of inertia are removed, since there are usually no heavy moving parts in electronic systems.

### Basic Principle

Most electronic and simple-circuit delay and timing systems are based upon the time constant of simple resistance-capacitance or resistance-inductance networks, or a combination of the two.

The delay action in each case depends upon the R-C or R-L values and the attendant time required for a current to build up or decay in these simple circuits. The retarding action of these reactances and resistances is utilized to obtain either postponed control actions or to measure actual time intervals.

The underlying principle of each circuit is explained briefly in this manner: (1) In a circuit containing a resistor and a charged capacitor in series, the capacitor discharge current will be limited by the resistor to an extent depending upon its actual value and the amount of current available. The time required for the capacitor to discharge completely will thus be determined by both the R and C values. The *time constant* of this circuit equals R times C (where R is measured in ohms and C in microfarads) and is the actual number of microseconds required for the current to fall to 37 percent of its initial value. The time required for the current to fall to 10 percent of its initial value is equal to 2.4 R-C microseconds.

A basic R-C delay circuit is shown in Figure 1. In this arrangement, when switch S is in position 1, capacitor C is charged by the battery (or other d.c. source). When the switch is subsequently thrown to position 2, the capacitor discharges through resistor R at a rate determined by the R-C product. Either the decaying current through R or the accompanying voltage drop across this resistor may then be employed to control a d.c. relay or a tube grid through some predetermined time interval. The manual switch S might be replaced with a vacuum or gaseous tube which would be arranged as an electronic switching device.

(2) In a simple resistance-inductance circuit (see Figure 2), the reactance of the coil retards the building up of current in the circuit. Thus, when switch S is closed, the battery forces a current through coil L, this

Figure 4.

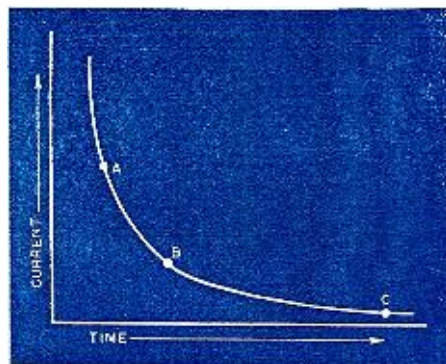



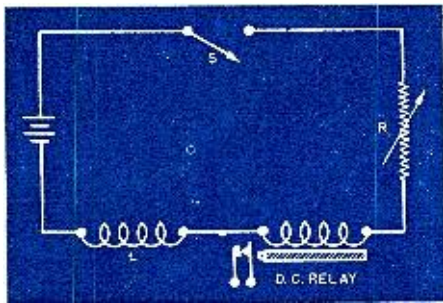

Figure 5.

current increasing in value at a rate determined by the values of R and L. The time constant of the R-L circuit is equal to  $L/R$  microseconds, which is the time required for the current to rise to 63 percent of its final value. Either the increasing current in the circuit or the accompanying voltage drop across the coil or resistor might be employed to control a d.c. relay or tube grid during the predetermined time interval. Here, as in case 1, the switch S may be replaced with a vacuum or gaseous tube as an electronic switching medium.

From the foregoing explanation, it is seen that operation may be obtained at practically any instant desired after a circuit is closed or interrupted. The technician needs only to choose the proper circuit constants from the equations to suit his requirements.

### Delay Circuits

It is often desirable in the control of electrical devices or machinery to have complete action occur at some stated time after a switch has been closed, or to have action continue for some time after a switch has been opened. For these purposes, delay circuits are employed, and descriptions of several such circuits follow.

**SYSTEM 1.** This system, most rudimentary of delay devices, is illustrated by Figure 3. The circuit embraces a capacitor C, d.c. source, double-position, single-pole switch S, timing resistor R, and sensitive d.c. relay. With the switch in position 1, the capacitor is charged. In switch position 2, the capacitor discharges through the circuit containing the resistor and relay, the decaying current following the general shape of the curve shown in Figure 4. At first, the current falls rather rapidly and then tapers off to a

slower rate of decay, until it is completely spent, although by proper choice of R and C values the curve may be made more gradual throughout or steeper at will. Likewise, if a single capacitance value is chosen, the resistor may be made variable, as shown in Figure 3, and a large number of time curves obtained by setting R at various values.

Depending upon the minimum current requirement of the relay, the contacts will be controlled over a portion of the time-current curve, such as between A and B in Figure 4. After reaching a minimum value (as at B), the armature of the relay will be released. If the relay contacts are normally open, the relay will close an external circuit during the delay interval. If, on the other hand, the contacts are normally closed, the relay

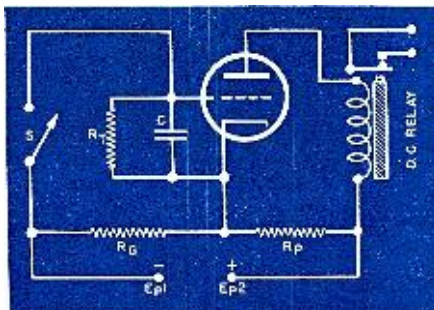

Figure 7.

will open an external circuit during the delay interval.

A highly-sensitive relay is required for operation in this circuit, in order that the armature may be actuated by the very low capacitor discharge current. At the same time, the inductance of the relay coil must be taken into consideration in the selection of R and C values, since this inductance will exert some influence upon timing.

**SYSTEM 2.** Almost the exact reverse of the operation just described may be obtained with the circuit shown in Figure 5. Here, timing is controlled by inductance and resistance components.

When switch S is closed, current flows through the circuit, building up slowly to a maximum value because of the inductance present, in a manner similar to that shown in the curve in Figure 6. The shape of this curve may be altered considerably by the

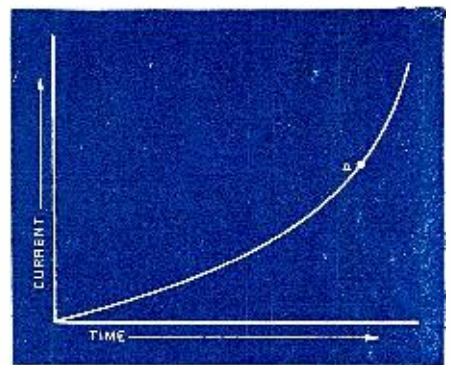

Figure 6.

actual value of the resistance with respect to a given value of inductance; hence by making R variable, as shown in Figure 5, various time intervals may be obtained.

When the current in the circuit rises to the minimum holding value required by the relay, as indicated by point A on the curve in Figure 6, the relay picks up and remains actuated until the circuit is again interrupted by opening the switch. In this system, control action occurs at some instant after the switch has been closed and continues until the switch is subsequently opened.

Very often, it is possible to dispense with coil L entirely and utilize the inductance of the relay coil exclusively as the L element of the timing circuit.

**SYSTEM 3.** The sensitive d.c. relay required by system 1 is relatively expensive and is frequently susceptible to vibration. More rugged relays require higher operating current than

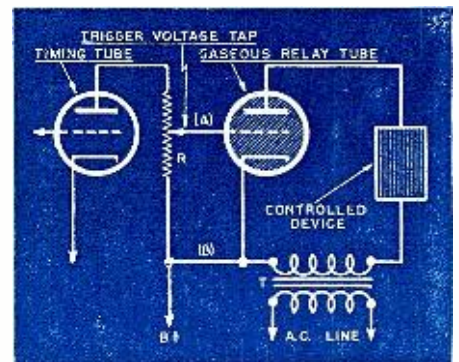
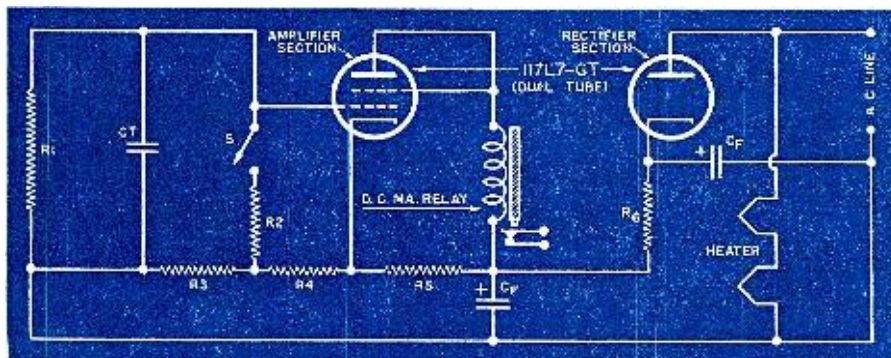

Figure 9.

may be supplied by the capacitor discharge. In order to utilize the low current level and accompanying low voltage drop in circuits of this type, the higher current relay may be interposed in the plate circuit of a tube, the latter's grid being actuated by the low-level delay circuit. Such a system is illustrated in the schematic diagram (Figure 7).

In this system, the type of tube is not important, as long as its normal plate current resulting from voltage impressed at terminals E1 and E2 is sufficient to actuate the d.c. relay. Plate voltage is obtained from the drop across resistor Rp, while grid bias voltage is obtained from the drop across resistor Rg. The latter is pro-

Figure 8.



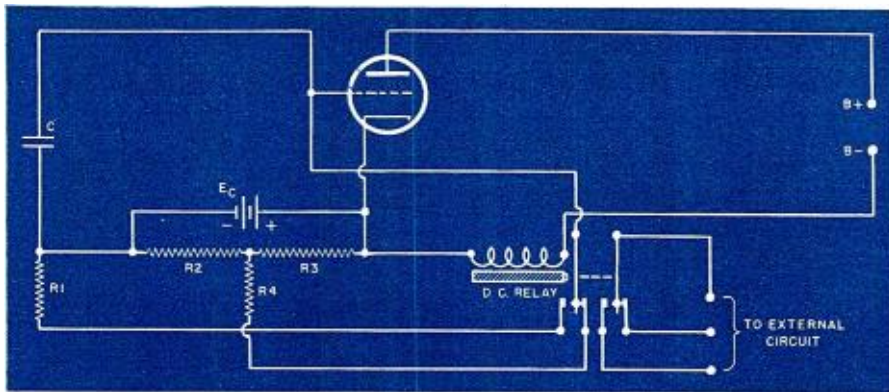

Figure 10.

portioned so as to make the grid highly negative, reducing the plate current below the level necessary to close the relay. When switch S is closed, this high negative bias is applied to the grid and the relay drops out.

Capacitor C is charged by the grid voltage when the switch is closed. When S is opened, however, the capacitor discharges slowly through its shunting resistor  $R_t$ , lowering the voltage of the grid. As the bias continues to fall, the plate current accordingly rises, finally reaching a value at which the relay will be automatically actuated.

The time delay obtained in this circuit is approximately three seconds per microfarad (in C) per megohm (in  $R_t$ ) for a d.c. voltage (at E1 and E2) of approximately 100 volts. The values of  $R_p$  and  $R_g$  will depend upon the type tube employed in the circuit:  $R_p$  will be large enough to develop a plate-cathode voltage (as measured with a very high-resistance d.c. voltmeter) such that the grid voltage developed by  $R_g$  will reduce the plate current sufficiently to drop out the relay. By making  $R_t$  variable, various time delays other than that stated above may be obtained at will.

**SYSTEM 4.** The circuit of Figure 8 shows a compact tube-type delay circuit requiring only one tube for both power supply and timing functions. A 117L7-GT is employed.

In operation, closing the switch permits capacitor  $C_t$  to charge through the resistor  $R_2$ , 100 to 200 ohms. The grid bias voltage is thus the drop across  $R_4$ , a value sufficiently low to permit the relay to be picked up.  $C_t$  discharges through  $R_1$  when the switch is opened, increasing the bias voltage

Figure 11.

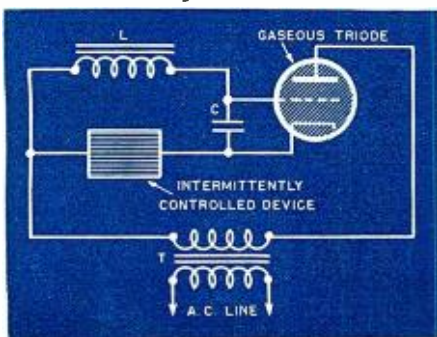

until the reduced plate current causes the relay to be dropped out.

$R_3$ ,  $R_4$ , and  $R_5$  are sections of a 50,000-ohm 75-watt wirewound resistor. The taps are adjusted to obtain a value of plate-cathode voltage (developed across  $R_5$ ) of such value that the bias voltage (developed across  $R_4$ ) is not quite high enough to drop out the relay.  $R_6$  is a 2500-ohm 25-watt filter resistor, and the capacitors  $C_f$  each 8- $\mu$ fd. 450-volt electrolytic filter units. This unit is a.c. operated requiring no transformers, or it may be operated directly from a direct-current power source.

**SYSTEM 5.** In some control operations, it is desired to make and break

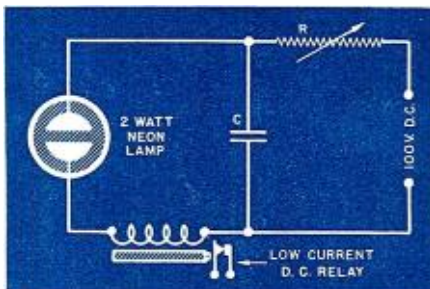

Figure 12.

a load circuit at a definite rate. Such operations include the flashing of advertising lights, signal systems, life tests of machinery and devices, and similar applications. Figure 10 illustrates one circuit for accomplishing this intermittent action by means of delay action.

Here the actuating switch shown in the preceding schematics is replaced by a pair of auxiliary contacts on the relay, so arranged that when the relay is released, the timing capacitor is automatically switched back into the charging circuit.  $R_4$  is the timing circuit resistor, and the battery  $E_C$  represents the d.c. charging voltage source.

**SYSTEM 6.** Thyatron tubes may be employed to control an electrical device directly without the intermediary of a relay. The gaseous tube selected need only pass sufficient anode current to operate the device, its grid voltage being obtained from a resistor in the plate circuit of the timing tube. A suggested arrangement is shown in Figure 9.

The timing tube is assumed to be

included in a circuit of the type described in the foregoing paragraphs. The customary d.c. relay is replaced in its plate circuit by the load resistor R. A portion of the voltage drop across this resistor is selected by means of a tap and applied as bias voltage to the gaseous tube grid. The value of this voltage and its polarity will depend upon the type of gaseous tube employed as an electronic relay, since various types of Thyatrons require various trigger voltages, some being positive and some negative. Figure 9 indicates a positive trigger voltage applied to the gaseous tube grid. If the actual tube employed by the reader requires a negative triggering voltage, the leads (a) and (b) need only be reversed.

Plate voltage to the gaseous tube is supplied by the transformer T. The controlled machine is connected directly in the Thyatron plate (anode) lead, as shown.

Operation of the circuit follows the scheme of the system adopted for the timing portion of the circuit and may be any of the systems described up to this point. The only difference in the arrangement is the substitution of an electronic relay for the usual electro-mechanical relay. Whether the circuit starts or stops the controlled device depends upon the R-C timing circuit actuating the grid of the timing tube.

**SYSTEM 7.** Gaseous triodes may likewise be employed in intermittently-operated systems, such as flashers and interrupters, completely eliminating the relay specified in Figure 10. Such a circuit is shown in Figure 11. Here, the Thyatron chosen passes sufficient anode current to operate the intermittently-controlled device directly, and is powered directly by the transformer T.

Action of this circuit is based upon the retarding effect of the inductor L upon charging current flowing into capacitor C. The rate at which the intermittent control occurs may be set by choice of L and C values.

When current is passing through the controlled device, the capacitor charges at a rate determined by the

(Continued on page 78)

Figure 13.

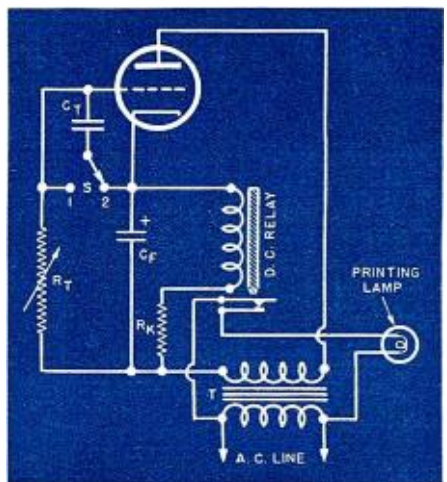

# ELECTRO-MEDICAL APPARATUS

by JOHN KANE

*A study of service problems encountered in electronic-controlled units.*

THE radio serviceman sometimes finds it necessary or desirable to be able to make minor repairs on X-ray or other electro-medical equipment. This may be due to an emergency or when the regular maintenance service of the manufacturer is too slow or the manufacturer has gone out of business. This article is intended to acquaint the technician with the basic principles of equipment used in the medical field.

X-rays were discovered by Roentgen in 1895. Here was one of the foremost developments in the electronic art before the catchword of "electronics" had been coined. The X-ray tube is much like a high voltage radio tube. It has two elements, a cathode and a plate of special shape. Roentgen found that when high velocity electrons from the cathode struck the tungsten plate X-rays were generated. In some tubes a platinum plate is used. The hard X-rays extend

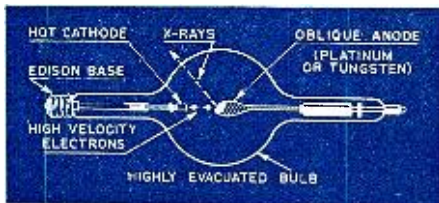
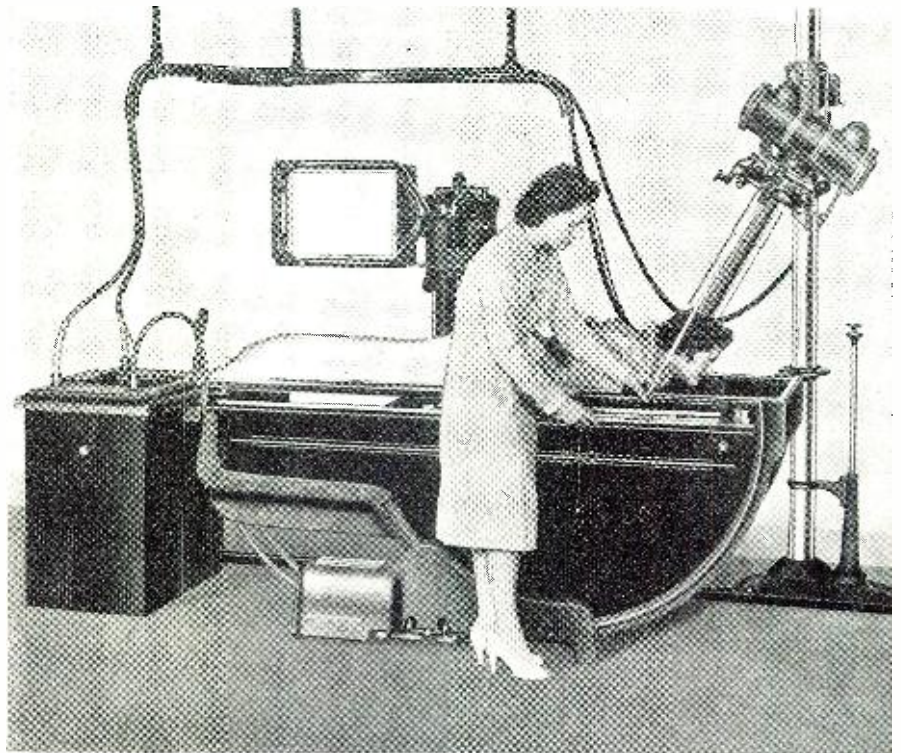

Fig. 1. Coolidge X-ray tube.

up to  $10^{20}$  cycles per second, the soft to  $10^{19}$  c.p.s., while the highest radio frequency signal produced electrically is about  $10^{13}$  cycles per second. The frequency of visible light is about  $10^{15}$  cycles per second. The frequency of ultra-violet light is from  $10^{15}$  to  $10^{17}$  c.p.s., infra-red from  $10^{13}$  to  $10^{14}$ , approximately.

In connection with X-ray apparatus we find that there are three rather imposing names given to the applications of the equipment. The first is Roentgen Therapy. The word therapy signifies a treatment for disease. Thus, we may have occupational therapy for mental cases and in X-ray work we have Roentgen Therapy for physical ailments. But this is a matter for the X-ray technologist and medical terms need have no great concern, as far as the electrical expert is concerned, beyond understanding the requirements



Modern type of combination X-ray and fluoroscope equipment. Extreme flexibility of the table and equipment makes it possible to examine thoroughly any part of the body.

of the device. His job is to repair apparatus.

The kind of X-ray equipment used for therapeutic use, exposure of body parts to radiation, depends upon the region that is to be treated. Remembering that 1 meter equals  $10^{10}$  Angstrom units, we may convert frequency in cycles to wavelength in meters and then convert to Angstrom units (A). For skin treatment it has been found that Grenz rays are useful, having a radiation wavelength of 2 to several hundred A units. The X-ray tube voltages range from 135,000 to 300,000 peak. A filter is placed between the source of rays and the patient. It consists of a few millimeters of aluminum, a few tenths of a millimeter of copper or some combination arrangement. The filter absorbs a great deal of the low frequency radiation that otherwise would be absorbed by the skin. The rays that get through the filter are applied to the area to be treated. In treating cancer, gamma rays have been used successfully but so far the use of X-ray tubes for producing gamma radiation has not been proven an absolute success. Experiments have been carried on with tubes worked at 300,000 to 1,200,000 volts.

Radio amateurs and commercial operators, as well as others having familiarity with high power, will find the circuit of Fig. 2 recognizable. Usually a half-wave rectifier is employed using a tube for changing the a.c. wave into d.c. and in many cases volt-

age doubling is used. The half-wave voltage doubling arrangement shown in Fig. 2 is typical and widely used in the medical profession.

The weight of a typical, complete installation may range from 990 to 1760 pounds which is not unusual considering massive equipment necessary.

As is well known, X-rays are detected by photography. It was in fact accidental that Roentgen discovered the rays, observing the peculiar effect on a photographic plate connected with some other experiment on which he had been working. X-rays also have the power to excite fluorescence. They are not affected by a magnetic field. They are reflected to some extent and slightly refracted by prisms and lenses, indicating the optical qualities of the radiations, but also have the well known and remarkable power

Fig. 2. Half-wave voltage-doubler X-ray therapy apparatus.

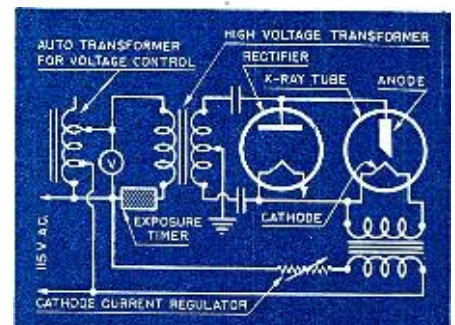

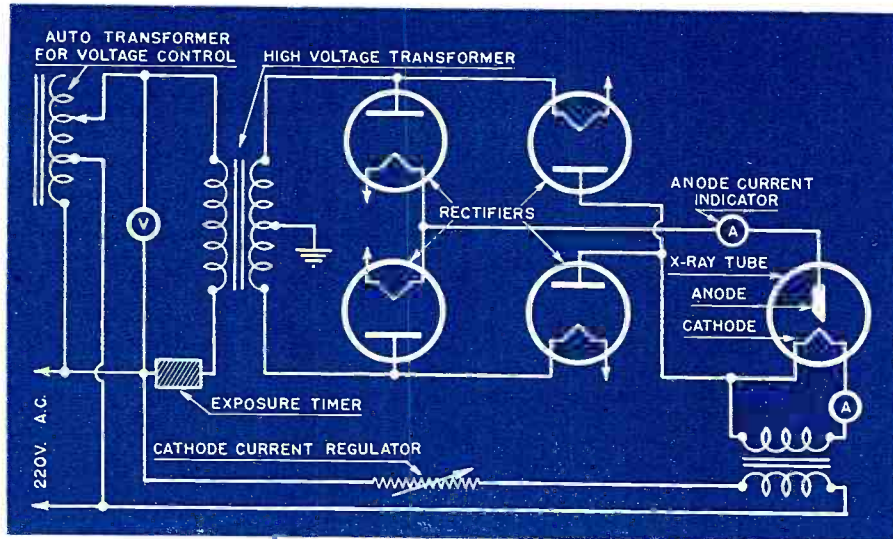

Fig. 3. Schematic diagram of full-wave single-phase Roentgenographic machine.

of penetration of substances of small density, such as wood, pasteboard or body tissue which are all opaque to ordinary light. They penetrate metals to a lesser extent, considerable attenuation being observed in the more dense metals such as platinum and lead. Nevertheless industrial uses for X-rays in analysis of steel and iron have been found.

Fine crystals of barium platinum cyanide or calcium tungstate may be deposited upon a piece of pasteboard and if brought in a dark room before an X-ray beam, the pasteboard will glow. Body tissue, being transparent to the rays, will show but faintly while the bones will cast a strong shadow. By substituting a photographic plate

for the fluorescent screen we can obtain an X-ray photo, showing broken bones, etc., of any part of the body.

### The Coolidge X-ray

This tube (Fig. 1) is a highly evacuated type with a hot cathode, the voltage which may be applied being limited only by the spark-over characteristic of the tube, large tubes being operated on voltages as great as 200,000 and even higher. The high potential tubes have electrons in them traveling at extreme velocities and produce X-rays of great penetrating force. This necessitates careful screening of the apparatus with sheet lead, or an equivalent material, which absorbs radiation and prevents X-ray burns

which are serious and dangerous to the operator of the equipment.

### Classes of X-ray Apparatus

The three forms of roentgenographic machines may be arranged categorically in the following way: single-phase, three-phase and condenser discharge. The first part of the word roentgenographic is of course taken from the inventor's name, Roentgen, while the second part indicates a written record. The apparatus which records is thus a roentgenographic and that which permits a visual inspection is roentgenoscopic. The science of X-ray seeing is roentgenoscopy (fluorescent action).

A complete dental apparatus of the self-rectification type may weigh about 265 pounds. It may occupy a space of about 24 x 24 x 80 inches. The film used is generally contained in a light tight cassette (box used by photographers as a plate holder) having a front plate of thin bakelite or thin aluminum. Two intensifying screens are used in the cassette, one on either side of the film and maintain close contact with it when the cassette is loaded. The X-rays pass through the screens and produce a fluorescent effect in the calcium tungstate or zinc sulfide contained and the resultant light radiation acts upon the film. About 5% of the density is caused by the absorption of X-rays in the film and the screens produce the other 95% in modern equipment. To control contrast in the roentgenograms, the X-ray tube voltage is varied. For roentgenography of the chest and heart, exposures of  $\frac{1}{120}$  to  $\frac{1}{5}$  second are used, while other parts of the body may be X-rayed at exposure times of  $\frac{1}{2}$  to 20 seconds. The X-ray tube current is measured by a standard milliammeter for exposures longer than 3 seconds. The X-ray tube voltage is generally measured by means of a sphere gap and calibrated for the given value of used current, being checked against the primary voltmeter reading.

For exposures of very short duration, a ballistic milliamper-second meter is used to measure the total value of current passed through the X-ray tube and the timer is arranged to make and break the contact controlling primary current at zero points of the first and last cycle of exposure. The distance between the target of the tube and the film generally ranges from about 18 to 80 inches. The anode current indicator shown in the plate circuit (Fig. 3) of the X-ray tube is a ballistic milliamper-second instrument. The X-ray tube current for general roentgenoscopy may range from 5 to 10 ma., while in roentgenography the current may range from 50 to 1000 milliamperes average.

One of the most spectacular and at the same time one of the most useful applications of radio technique is in connection with electrosurgery. One large electrode is applied to the body and the other electrode is a large

(Continued on page 58)

Fig. 4. Wiring diagrams of several most widely used types of diathermy apparatus.

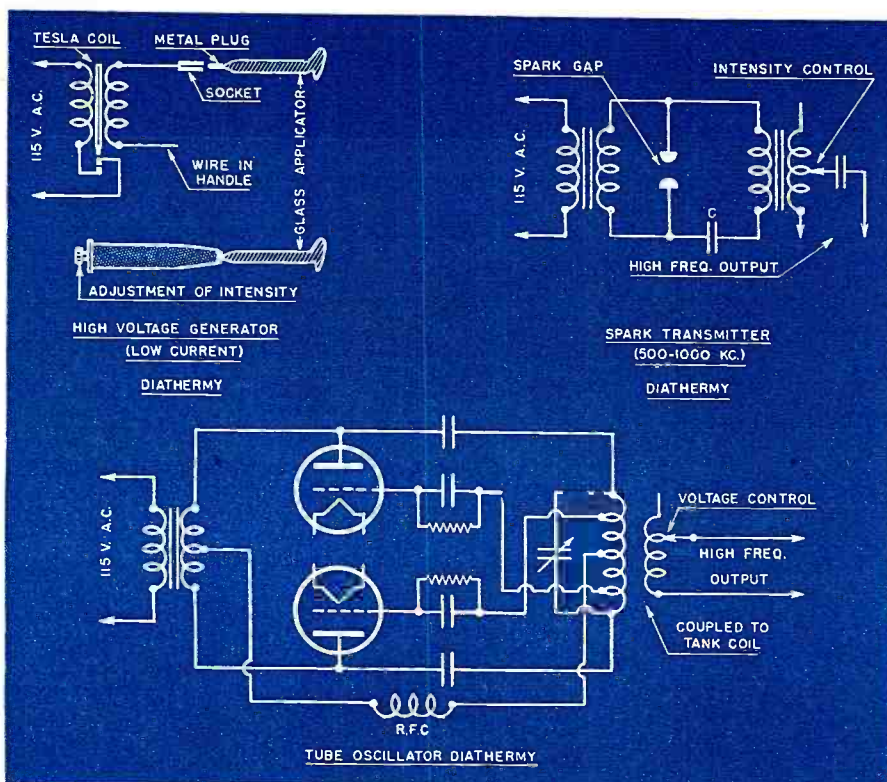

# Manufacturers' Literature

Our readers are asked to write directly to the manufacturer for this literature. By mentioning RADIO NEWS and the issue and page, we are sure the reader will get fine service. Enclose the proper sum requested when it is indicated. This will prevent delay.

## STANCOR'S NEW TRANSFORMER CATALOG

The Transformer Encyclopedia of the Radio and Electronic Industry contains detailed specifications covering Stancor's complete line of transformers and chokes for replacement and general purpose use. A handy classified and numerical index and price list permit instant location and cost estimate of the item you want. Many pages are devoted to transformers designed for special shop, laboratory, and industrial applications. Catalog is illustrated throughout with mounting types available. Send your request for a copy of Catalog No. 140 to the Standard Transformer Corp., 1500 N. Halsted, Chicago, Ill.

## WAR TIME TUBE SUBSTITUTION CHART

The Sales Engineering Department of National Union Radio Corporation at Newark, New Jersey released this week for distribution through National Union distributors a War Time Tube Substitution Chart which includes a functional cross index.

The compilation indicates substitutions of approved Government types for 288 types available prior to the Government limitation order.

Preferred substitutions are shown in each instance and types are coded to indicate necessity of changes such as changing sockets, changing bias, using external shield, using filament shunt, rewiring sockets, etc.

In addition to the interchangeability listing a functional cross index shows the replacement with regard to functional considerations vs. heater considerations.

A copy of the chart may be obtained by recognized servicemen and technicians on request to National Union distributors in local areas.

## MANUAL OF SIMPLIFIED RADIO SERVICING

By Lieut. Col. J. G. Tustison, U. S. Army Signal Corps. Published by Allied Radio Corporation, 833 West Jackson Boulevard, Chicago, Illinois. Forty pages, pocket-size, 5" by 3¼". Price, 10c.

This booklet describes practical field-tested short-cut methods for servicing Electronic and Radio devices with only the simplest equipment and tools. Many methods described are those used by our armed forces for servicing

(Continued on page 66)

# WAR—BY RADIO

by S. L. SOLON

ON THE morning of May 30, 1916, an observer in the Royal Navy bent over his wireless direction-finding equipment. He twirled the knobs of the somewhat clumsy apparatus, listening carefully to the staccato crackling of the ether.

Had the time come? He must be certain before he reported.

Again he checked his results. More than a new technique of direction-finding was in the balance. The Grand Fleet strained at anchor waiting to engage the Kaiser's armada.

The observer lifted his phone. "Beg to report, sir, there is unusual signaling activity among the German ships at Wilhelmshaven." All that morning the reports poured into the office of the First Sea Lord, Sir Henry Jackson. In the afternoon wireless direction-finding observers reported that a German battleship had moved a few miles northward.

This was the final link in the chain of evidence built up during the day by wireless direction-finding. The German Fleet was about to put to sea.

Sir Henry ordered the Grand Fleet to sail at once. It sailed into history by the victory over the German Fleet in the Battle of Jutland. And it was the first elementary steps in wireless location that made this smashing blow to German sea power on the high seas possible.

The fuse of the great Battle of Jut-

land was lit by a tense young man, listening to the electrical pulse-beat of the German Fleet crackling through the ether. The instrument he depended on—the tangled web of wire coils, luminescent valves, sputtering electrodes like the living organs of some mechanical Scylla—was the grandfather of modern radiolocation. It is radiolocation, sturdy shield to the R.A.F. lance, that shares the glory of the Battle of Britain.

Greatest achievement in wireless warfare in the Second World War, radiolocation is but one of many developments in war by radio which have kept the experimental laboratories on a 24-hour daily working schedule since the Nazi Panzer colossus rumbled over Poland in the fall of 1939.

The full story of the Battle of Science cannot be told until the war is won. The endless quest for new techniques, new weapons, new means for attack and defense is, like the story of any battlefield, a record where success alternates with failure, heroism with disaster, heartbreak with achievement.

Men die in agony, are maimed and shattered in the secret Battle of Science as inevitably as the soldiers on other battle-fronts of the world.

In every phase of warfare—mechanization, aircraft, ordnance, communications, munitions and morale—science presses forward. Perhaps the most sensational developments, however, have taken place in wireless warfare—the use of the invisible air waves as a vehicle for attack and defense.

It is in radio warfare that the most startling and interesting possibilities lie. I have talked to men who are working in this field—the explorers of invisible worlds and the experimenters in invisible matter—and as far as it was possible I have watched what they are doing. Here are the notes of this brief glimpse into the Battle of Science and some of the accomplishments of the men who are fighting it.

Writing of "War in 2030," the Earl of Birkenhead a few years ago



# PRACTICAL RADIO COURSE

by ALFRED A. GHIRARDI

**Part 16 of the series, covering the present day design characteristics and circuit application of power amplifier tubes.**

THE operation of all practical forms of loudspeakers in common use in radio receivers and sound amplifier systems (see Fig. 1) depends upon the fact that a varying current flowing through their actuating windings produces motion of some sort of diaphragm which results in the production of sound waves. This varying signal current flowing through the loudspeaker winding constitutes a supply of *electric power* that is being delivered to it for its operation.

It is important to remember that the amplitude of the *variations* in the current, not the *total* amplitude of the current itself, determines how great the amplitude of the diaphragm vibrations produced will be and, consequently, how intense the resulting sound waves will be. In other words, the greater the amplitude of the variations in the signal current, the louder the reproduced sound will be. (These variations or fluctuations are the useful portion of the total plate current of the tube or tubes feeding the loudspeaker, and are referred to as the *a.c. component of the plate current*.)

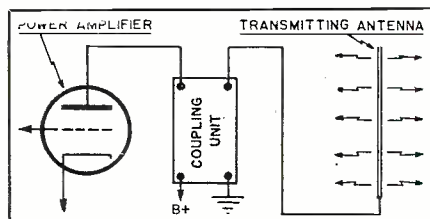

Fig. 2. Power transfer into antenna.

Since the impedance of a loudspeaker is constant at any particular frequency, it is evident that by increasing the amplitude of the signal current flowing through its actuating winding a larger amount of electric power will be delivered to the loudspeaker and the sound will be louder.

Since it is the *electric power* of the amplified signal fed to it that actuates the loudspeaker, the function of the tube or tubes immediately preceding the loudspeaker is to deliver the maximum possible amount of *undistorted signal power* to the loudspeaker. For this reason they are called the *power amplifier tubes*, or simply the *power tubes* of the amplifier (Fig. 1).

The case of the tubes employed in the radio-frequency amplifier of a ra-

dio transmitter is similar. In order to radiate signal energy from the transmitting antenna electrical signal power must be delivered to the antenna circuit (Fig. 2). Consequently, it is the signal *power* output obtained

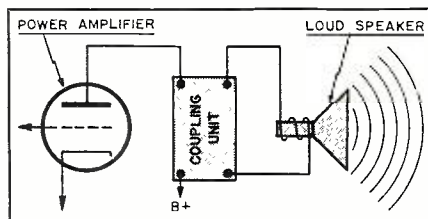

Fig. 1. Tube used to operate speaker.

from the radio-frequency amplifier tubes feeding the antenna circuit that is important here, and these tubes are called the radio-frequency *power amplifiers*.

When vacuum tubes are employed as amplifiers in an electronic circuit where a relay, solenoid, electromagnet, lamp, etc. (see Fig. 3), is to be operated directly from the plate circuit of an amplifier tube, the tube is being called upon to deliver electrical *power* to the device it is to actuate. In such applications it is usually desired to obtain the maximum *power* output from the tube, consistent with conservative operation of the tube within its ratings. Signal distortion here is usually of no consequence.

### Difference Between Voltage and Power Amplifier Tubes

The question that now arises is what determines whether a tube is a *voltage* amplifier or a *power* amplifier. First of all, it is the circuit constants of its coupling network and, to some extent, the voltages applied to its various elements. Thus, a tube is called a *voltage* amplifier when the circuit constants of its associated coupling network are so adjusted that the tube will deliver as much signal *voltage* as possible to the following device (which is usually the grid circuit of another tube). On the other hand, if the circuit constants of the coupling network are so arranged that the tube will deliver as much *power* as possible to the succeeding device (such as a loudspeaker, etc.) it is called a *power* amplifier. (An exception arises when a voltage amplifier tube is used as a *driver*, in which application it must

also deliver *power*.) It is evident from this that *any* amplifier tube may be used either as a voltage amplifier or as a power amplifier by making the proper circuit constant adjustments. However, certain tubes such as the types 50, 2A3, 6K6, 6L6, etc., are designed to operate more advantageously as power amplifiers than as voltage amplifiers when used in suitable circuits, so they are called *power amplifier tubes*. Similarly, when properly used, other tubes such as the types 56, 6F5, 6J7, etc. perform more advantageously as voltage amplifiers than as power amplifiers, hence they are known as *voltage amplifier tubes*. Nevertheless, regardless of this distinction, the same fundamental theory of vacuum tube amplifier action applies equally well for all tubes whether they are voltage amplifiers or power amplifiers. Also, power amplifier tubes produce some voltage amplification as well as power amplification, as we shall see later.

### Power Tube Construction Features

There are several considerations in the design of tubes intended specifically for power amplification duties which makes them differ in construction from the voltage amplifier tubes. Since they must deliver signal power to the load and have large plate currents, the *plate resistance* must be low so there will not be too much power dissipated and wasted within the tube itself. Remember that, in general, power dissipation is a function of  $I^2$  and of  $R$ . All power dissipated in the internal plate resistance of the tube ( $I_p^2 \times R_p$ ) produces only heat within the tube, and is therefore a total waste of a portion of the power supplied to the plate circuit by the plate supply source. Furthermore, this wasted power produces heat which raises the temperature of the internal parts of

Fig. 3. Plate current relay operation.

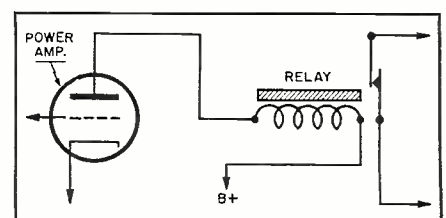

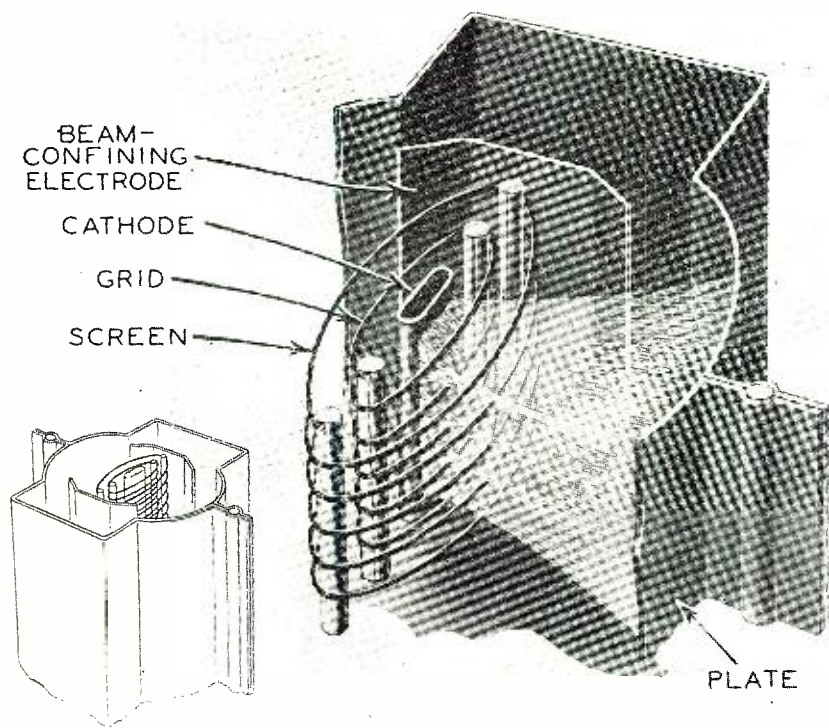

Element arrangement of beam power-output tube. Concentrated electron stream, free from secondary emission, makes possible the high power sensitivity of such tubes.

the tube and so limits the useful power handling capabilities of the tube.

Since the signal voltage has been amplified by preceding voltage amplifier tubes before it reaches the grid circuit of the power tube, this tube must be capable of handling, without distortion, quite large variations of signal voltage. This means that its  $E_g - I_p$  characteristics curve must be straight over a comparatively large range of grid potential. This is accomplished by using a widely spaced grid.

Since a widely spaced grid must be used, the amplification factor of the tube becomes comparatively low because such a grid has a comparatively small amount of control over the electron stream moving from cathode to plate. Thus, most power tubes have a fairly low amplification factor (for example the  $\mu$  of a 6A3 power amplifier triode is 4.2, that of a 6A4 power amplifier pentode is 150, etc.).

The amount of power that a tube can handle is determined by the plate voltage that may safely be applied to the tube, by the electron emission of the cathode and by the amount of

heat that can be dissipated within the tube without overheating its parts. The large plate current required in power tubes (so that they may deliver large power to the load) necessitates the use of cathodes having a large surface area so that they may emit the copious stream of electrons necessary.

plate of the tube. Consequently, the plate has to be large enough so it is capable of radiating all the heat generated at its surface, and also the heat radiated to it by the cathode and other elements, without damage or adverse results such as secondary emission, etc. The size of the plate and the glass envelope of air-cooled tubes is proportional to the power capacity.

In tetrode or pentode type beam power tubes, because of the effective suppressor action provided by the space charge, and because of the low current drawn by the screen (see Part 10, Feb. 1943 issue), the advantages of high power output, high power sensitivity, and high efficiency are obtained.

### Power Amplifier Circuit Consideration

In radio receiver applications, for a given signal input the power tube is required to release the maximum amount of undistorted signal power in its plate circuit which, of course, is subsequently transferred to the load. Even though a particular tube may be especially designed to operate as a power amplifier, it will only perform satisfactorily in that capacity when used in properly designed circuits, having the proper circuit constants, and when the correct potentials are applied to the various tube elements. The power tube, together with its associated circuit components, constitutes one complete power stage.

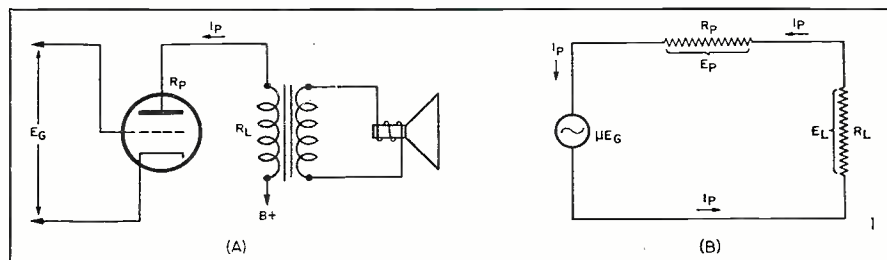

Fig. 4. Triode output tube used to actuate a speaker, and its equivalent circuit.

In some power tubes such as the 6A3, two cathodes in parallel are used.

In order to withstand the high plate voltages employed with some power tubes, it is necessary to provide ample insulation between the plate and other electrodes. In glass envelope type power tubes, the plate, grid, and cathode leads are commonly brought out through separate parts of the glass envelope in order to provide the maximum possible insulation.

The total power dissipated within the tube itself consists of the internal plate and grid circuit power losses plus the power used for heating the cathode. All of this heat must be carried away from the elements, principally through the envelope of the tube. A major proportion of the energy which is to be dissipated is produced at the

The power output of any given vacuum tube is dependent on the direct operating voltages applied to the various electrodes, on the external load impedance connected in the plate circuit, and on the magnitude of the exciting (signal) voltage applied to the control grid. In any case, the operating conditions are subject to the maximum safe limiting values placed by the manufacturer on electrode voltages, electrode power dissipation, and space current drawn from the cathode (these values may be obtained from the tube characteristics charts published by the manufacturer). The power output obtainable under actual operating conditions in audio amplifiers also depends upon how much distortion from second and higher-order

(Continued on page 60)

Fig. 5. Pentode power output stage.

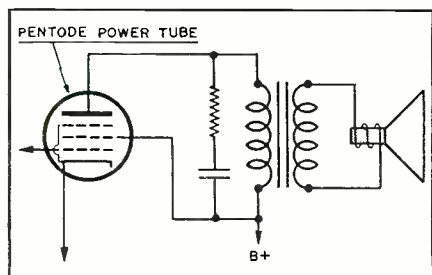

## TECHNICAL BOOK & BULLETIN REVIEW

**"BASIC ELECTRICITY FOR COMMUNICATIONS,"** by W. H. Timbie. Published by *John Wiley & Sons, Inc.*, 440 Fourth Ave., New York City. 590 pp. plus index. Price \$3.50.

This book presents basic electrical principles used in the communications and industrial electronic fields. The plan followed is that which has proved successful in the author's *Elements of Electricity*. Facts and theories are presented by simple direct statements. The book contains an adequate amount of information concerning electrical laws and communication practice in an immediately usable form. Furthermore, it applies the information contained to real situations and modern equipment and not to abstract theory and the jungle of mathematical formulas. It confines itself to adequate treatment of a few fundamental ideas, rather than to a discursive treatment of many. It includes only the elementary electrical principles and their application to modern communication practice and to the rapidly growing field of industrial electronics.

**"FIRST PRINCIPLES OF RADIO COMMUNICATIONS,"** by Alfred P. Morgan. Published by *D. Appleton-Century Company*, New York-London. 353 pp. Price \$3.00.

This complete, simple practical course for either individual or group instruction will give the novice a thorough knowledge of radio communications. It starts with basic electrical principles and unfolds each and every subject in simple and logical style. The beginner is given a complete basic understanding of the principles that make each part of a radio transmitter and receiver work, and gradually develops the subject of radio practice. Mathematics has been almost entirely avoided. A few important electrical calculations are explained but they require only ordinary arithmetic or simple algebra for their solution. The book contains approximately 183 diagrams, making all subjects clear to the student. It is a most valuable publication for use in pre-induction courses in radio fundamentals for those who are entering the armed forces and want to specialize in radio communications.

**"ALLIED'S RADIO DATA HANDBOOK,"** by Nelson M. Cooke, Lt. U.S. Navy. Published by *Allied Radio Corporation*, Chicago. 47 pp. Price 25c.

This book fills the need for a comprehensive and condensed handbook of formulas and data most commonly used in the field of radio and radionics. It serves as a convenient source of information and reference. The handbook consists entirely of formulas, tables, charts and data. These are  
*(Continued on page 88)*

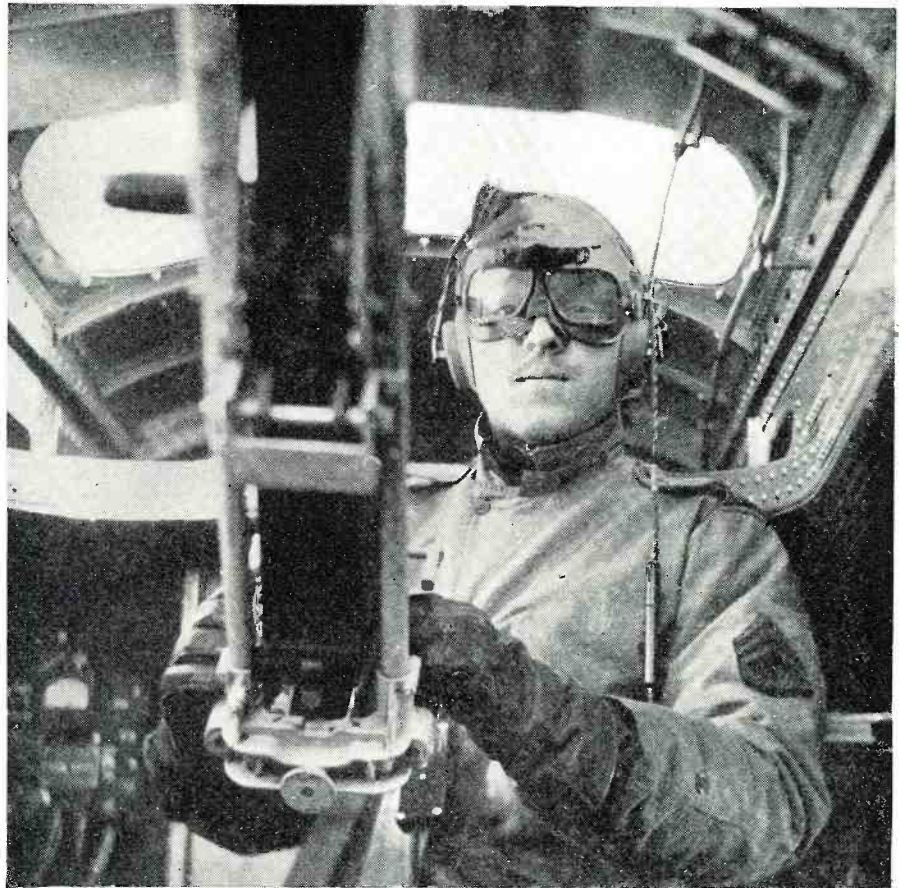

Radio operator-gunner Wm. Garrett, stands by for action in Flying Fortress.

# RADIOMEN IN COMBAT

**RADIOMEN** have to have what it takes, as their duties include everything from repairing the equipment and brass pounding to transmitter operation. As an added chore they man the guns to beat off enemy attacks. Whether high in the air in a Flying

Fortress or in a bouncing, jolting tank on the roughest terrain in the toughest outfits, radiomen are doing their jobs according to the highest traditions of the service, and making radio one of the major contributions to early victory and future world peace.

Radio-equipped Marine tanks in action over rough terrain.





# HOW COLOR COMPARATORS WORK

by JOHN KEATING

## A review of the fundamental electronic equipment used for the comparison of colors in industry.

IN several industries, photocells now examine, sort, or match colors with greater precision and less chance of disagreement than has hitherto been possible with trained specialists. Radionic color comparators evaluate colors in quantitative terms, exhibit excellent retrace characteristics, and experience no fatigue. Organizations employing these instruments now include textile mills; fitters of auto-

sents a considerable frequency band, even when we concede that the visible spectrum is relatively narrow. Most colors are of complex waveform.

The color comparator, in order to be an effective instrument, must evaluate all colors presented to it in terms of hue, saturation, and brilliance. When the instrument is employed for matching purposes, failure to take one of these attributes into cognizance will entail faulty indications. A skilled inspector may experience little difficulty in matching similar colors by eye when viewed together. However, when examined separately, even under identical lighting conditions, sharp differences of judgment arise between different inspectors. This is chiefly because the eye cannot differentiate sharply between small differences in hue, saturation, and brilliance contained in psychological color stimulus.

The most rudimentary type of color meter is illustrated in Figure 1. In this arrangement, monochromatic light delivered by an appropriate optical system penetrates a transparent or translucent color material (or is reflected from an opaque colored material) and impinges upon a self-generating photocell. The latter, in turn,

actuates a sensitive d.c. micrometer. An identical circuit has previously been shown as a turbidity meter for use in chemical analyses.

Obviously, the limitations of this simple instrument are severe, chiefly because of its lack of selectivity. If transparent materials, such as solutions in test tubes, are examined, they must necessarily be of constant turbidity, otherwise identical microammeter deflections are apt to be obtained for different colors.

Introduction of primary-color filters between the light source and the test sample will introduce a degree of selectivity. In a color comparator, due to Barss, Knobel, and Young and manufactured some time ago by General Radio Company (see Figure 2), these further refinements have been introduced without unduly complicating the instrument.

In this unit, the colored material receives light directed from a monochromatic, constant-intensity source through primary color filters and reflects this light to a self-generating photoelectric surface which is connected directly to a sensitive d.c. meter. Three light frequency bands, corresponding to the red, blue, and green

(Continued on page 50)

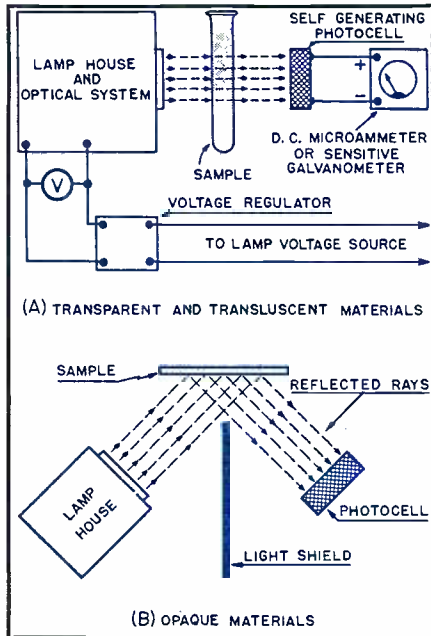

Fig. 1. Fundamental type of color meter.

mobile upholstery; chemical plants and laboratories; paint, dye, and ink factories; various industries which make use of color as an indication of the progress of certain processes; and many others.

To appreciate fully the degree of exactness afforded by the color comparator, we must first examine briefly the nature of color. Color, as a quality of visible phenomena, possesses three attributes: *brilliance*, which enables the observer to distinguish light, medium, or dark shades of the same color; *hue*, which differentiates one color from another and is what is ordinarily meant when the term color is used; and *saturation*, which expresses the vividness of a particular hue. When the eye receives a color stimulus, it evaluates each of these attributes to some extent. To be identical, two colors must match in brilliance, hue, and saturation.

The visible spectrum extends from 7800 angstrom units (red) to 3800 angstrom units (violet). The angstrom unit, standard for expressing the wavelength of light, is equal to 0.0000000001 meter, or one hundred-millionth of a centimeter. This repre-

Fig. 2. Diagram of a test unit, introducing color filters between light and test sample.

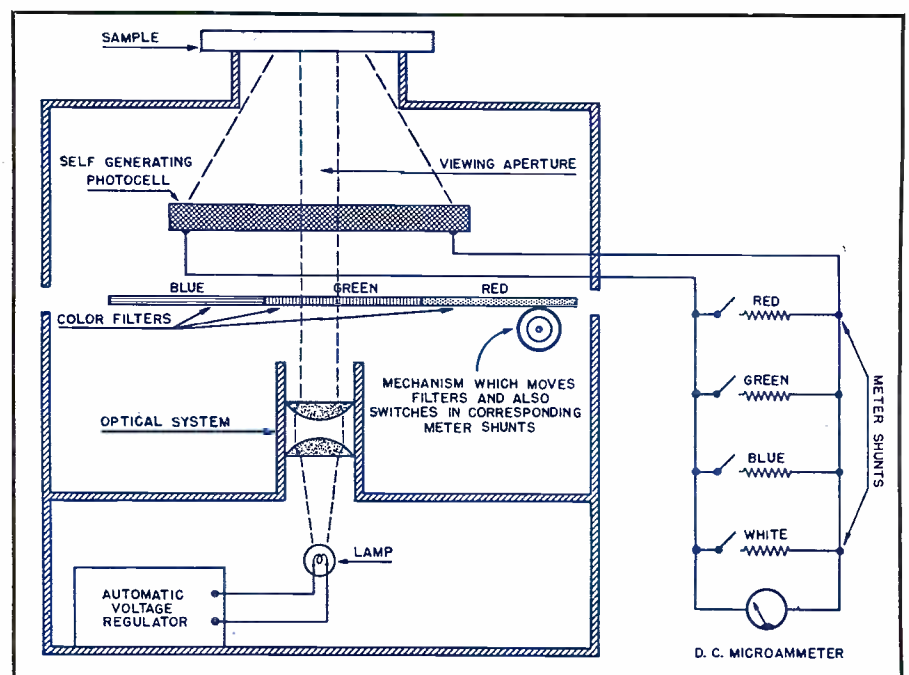

# WHAT'S NEW IN RADIO

New products for military and civilian use.

## NEW FEED-THRU TERMINAL BLOCK

A new multiple terminal block, for sub-panel and chassis construction, with feed-thru terminals, has just been announced. This new terminal block is designed to meet present-day demands of electronic and electrical



design, which require external terminals, because of their wiring simplicity and other advantages.

Terminals have ample clearances and leakage distances for circuits carrying up to 300 volts, 20 amperes. Center to center distance between terminal units is  $\frac{5}{8}$ ". No. 8 screws are used on each side of terminal units for securing connection. The two mounting holes at each end of the terminal base take No. 8 machine screws. These new blocks, known as *Curtis Feed-Thru Terminal Blocks* are offered by *Curtis Development and Manufacturing Co.*, 1 N. Crawford Avenue, Chicago, Illinois. Descriptive literature is available upon request.

## NEW 5-INCH OSCILLOGRAPH

Larger screen size together with the inclusion of a Z-axis amplifier to modulate the beam with any signal applied to its input terminals, or with a return trace blanking impulse produced by the linear-time-base generator, distinguishes this new Type 241 *Du Mont* 5-inch cathode-ray oscillograph from the previously announced 3-inch Type 224.

A development and product of *Allen*

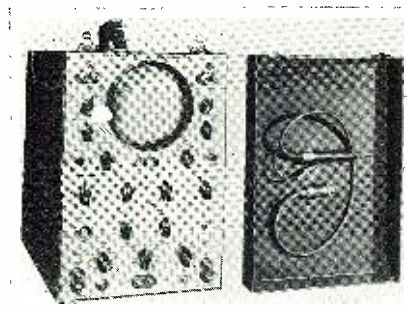

*B. Du Mont Laboratories, Inc.*, Passaic, N. J., this oscillograph has a uniform Y-axis or vertical deflection re-

sponse from 20 c.p.s. to 2 megacycles. It offers a comparably faithful square and sinusoidal wave response. The X-axis or horizontal deflection amplifier has a uniform characteristic from 10 c.p.s. to 100 kilocycles. Both amplifiers have distortionless input attenuators and gain controls. Provision is made to connect signals directly with the deflection plates when frequencies to be observed are beyond the useful limits of the amplifiers. Manufactured by the *Allen B. Du Mont Laboratories*, Passaic, N. J.

## NEW SELENIUM RECTIFIER

An important addition to the *I. T. & T.* Selenium Rectifier line was recently announced by Henry H. Scudder, Manager of the Selenium Rectifier Division of *Federal Telephone and Radio Corporation*, manufacturing subsidiary in the United States of International Telephone and Telegraph Corporation. The outstanding feature of this new

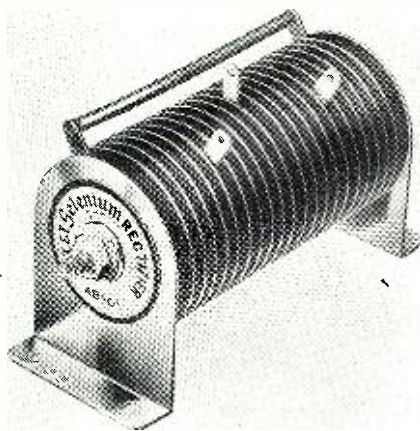

rectifier is the protection provided against excessive humidity and moisture conditions, encountered particularly in marine service. This improvement is made possible by a special assembly, which lends itself more readily to moisture-proofing. The standard petal-shaped brass contact washer and pressure-limiting fibre washer are not used. Instead a single metal washer is employed, making it possible to apply the protective coating to all exposed surfaces.

Production of this special type of rectifier for the armed services is already under way, according to Mr. Scudder, and will be turned to the filling of commercial needs following the war. Manufactured by the *Federal Telephone and Radio Corp.*, 67 Broad St., N. Y.

## TANDEM CONTROLS

A plurality of circuits—up to two dozen if desired—can be controlled by the single shaft of the "42" Series Control developed by *Clarostat Mfg. Co., Inc.*, 285-7 N. 6th St., Brooklyn, N. Y.

This new control was developed to

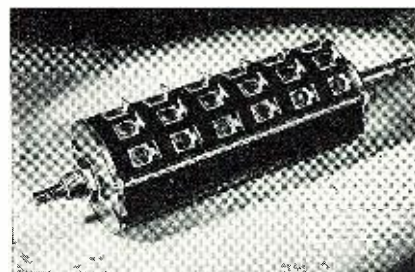

meet certain radio and electronic requirements calling for the single control of several circuits. To produce maximum rigidity in such tandem assemblies, as well as positive rotation of all units without the slightest backlash, the "42" Series construction has been worked out.

"42" Series Controls are necessarily made on special order only, since the number of sections and the values vary from one application to another. Units with as much as 20 sections are being produced for critical applications. Manufactured by the *Clarostat Mfg. Co.*, 285-7 N. 6th St., Brooklyn, N. Y.

## NEW TIME-DELAY RELAY

A new time-delay relay, specifically designed for aircraft applications where time-delay drop-out is required, has been announced by the *General Electric Company*. It is available in two sizes, one providing up to 0.4 second time delay, and the other up to 0.3 second time delay. On many applications, this relay can be used directly to control the desired device, while on others it may be desirable to have the relay actuate a contactor.

Designed for use in a wide range of ambient temperature—from plus 95° C to minus 40° C—both sizes are compact, suitable for mounting in an position, and corrosion proof, withstanding 95 per cent humidity at 75° C on 48-hour test and operating successfully immediately thereafter.

The normally closed, double-break, silver contacts of the relays will carry 20 amperes continuously at altitudes up to 40,000 feet above sea level. Also, the operating coils can be furnished for operation on either a 12- or a 24-volt circuit. Mfg. by the *General Electric Co.*, Schenectady, N. Y.

—50—

**I** RESENT shortages of equipment are taking us back to the ingenious earlier days of radio when experimenters, having less manufactured apparatus available at reasonable prices, devised satisfactory means for getting along without certain essentials. Added theoretical knowledge, amassed over almost two decades of radio progress, should bring forth a grade of ingenuity today superior to anything seen in the early days.

One very real present problem is the result of a growing shortage of variable condensers. The variable condenser long since supplanted other instruments for tuning radio circuits, and has become so firmly entrenched in modern circuit design that many technicians have almost entirely forgotten the L-C circuit in which capacitance is fixed and inductance variable.

The reasons for universal adoption of the variable condenser for tuning radio circuits were entirely logical. It is a compact, smooth-acting instrument in which considerable range of adjustment may be incorporated. As an air-dielectric device, its figure of merit may be maintained at a high value, and it is relatively simple in design in any of its many forms. At the same time, it lends itself admirably to ganged arrangements for single-dial control. These are paramount factors in modern design. But now that variable condensers are sorely needed for the armed communication and development services and the ci-

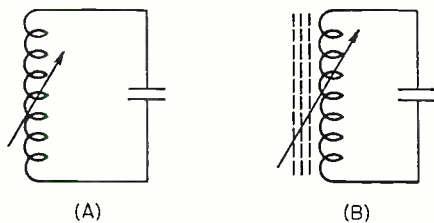

Fig. 1. Variable inductor symbols.

vilian supply grows slimmer, private experimentation can continue only if other means are embraced for the tuning of radio and radionic circuits.

The variable inductance offers a solution to the tuned circuit problem, an effective solution at that. There are several well-known methods of varying the inductance of a coil. Some are more adaptable to certain applications than others. All are effective. In general, it may be stated that any radio or radionic circuit normally tuned by means of a variable condenser may as readily be tuned over the same, or very nearly the same, range by means of a variable inductor, provided the designer selects the most efficient system for his particular application and provided, in some cases, that a somewhat reduced circuit Q may be tolerated.

In this article, there will be described several proven methods of constructing variable inductors. Actual tested examples will be presented. The writer has set up a series of these

# VARIABLE INDUCTORS

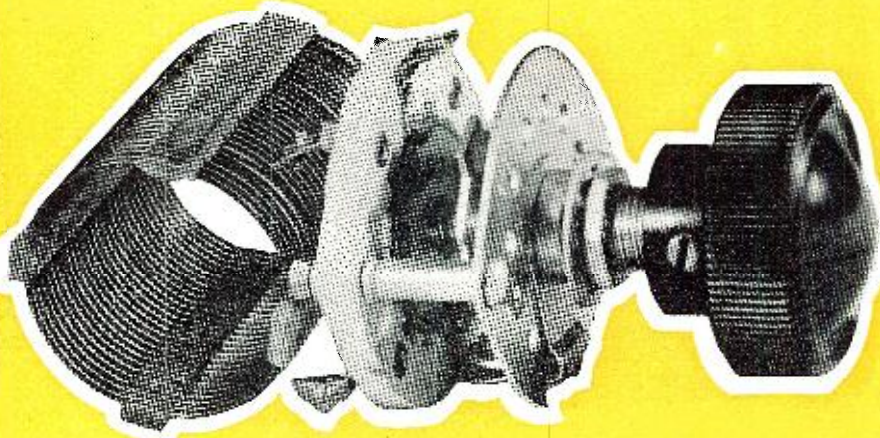

Fig. 3. Rotary switch used to vary the inductance of the coil.

by **GUY DEXTER**

**A study of variable inductance coils and their characteristics. Present shortages of tuning condensers point toward the use of these inductors in tuning circuits.**

coils expressly for treatment on these pages, and has performed those measurements which will establish the characteristics and relative merits of each type. Either of these coils may be employed in conjunction with a shunt-connected condenser to form a tuned circuit. There are many possible variations, electrical and mechanical, of each design, and the reader may make free use of his own ingenuity in applying these units to his individual needs.

Perhaps, it should be stated in the beginning that the variable inductor is no innovation. Many of the radio transmitters used during World War I and shortly thereafter employed tuned coils of one sort or another. And several commercial transmitters of comparatively recent design still incorporate them. Also, we have seen the re-introduction of the variable induc-

tor into broadcast receiver tuned circuits, since 1935, in the form of coils tuned by means of powdered-iron cores.

Variable inductor circuits are represented by the symbols shown in Figure 1, which indicate the presence of variable L and fixed C. Symbol A specifically designates a circuit in which the coil is varied in inductive value by some adjustment upon its number of turns or the inductive relation of its separate parts. Symbol B specifically designates a circuit in which the inductance is varied by means of some external component, such as a metallic slug or powdered-iron core, moved within the field of the coil. In either of these arrangements, the fixed condenser may be of the air dielectric type or may embody some solid dielectric. However, in order to keep the circuit Q as high as possible, mica condensers are universally employed in the absence of air-tuned units.

Fig. 2. Slider-tuned inductance.

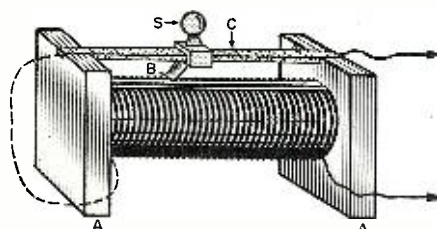

## Types

Of the several well-known types of variable inductors well known to radio technicians, the writer selected for test: (1) the slide-tuned coil, (2) tapped coil, (3) variometer, (4) powdered iron-core-tuned coil, (5) metal-slug-tuned coil, (6) metal-disc-tuned

coil, (7) shield-tuned coil, and (8) metal-ring-tuned coil. These particular types were chosen because they may readily be duplicated with simple tools by any experimenter. Considerable latitude is possible in adapting any of these types to individual applications of tuned circuits.

### Slide Tuner

The slider-tuned inductance is perhaps one of the oldest practical variable inductor. Its history dates back to the electrolytic and crystal detectors and early *soft* tubes. It is based upon the simple principle of varying the number of turns in the circuit by selecting a desired portion of the coil by means of a sliding blade-type con-



Fig. 4. The variometer.

tact. This type of variable inductor is shown in Figure 2.

The coil itself is wound, preferably with enamelled wire, closewound on an insulating form of bakelite, polystyrene, fiber, cardboard, or ceramic. The coil L is supported between insulating end supports, A-A, to which is

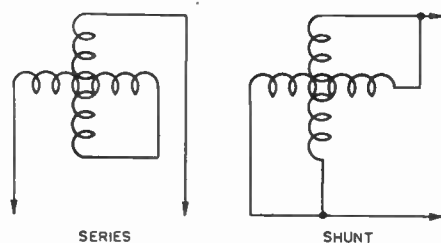

Fig. 5. Symbols used for variometer.

also attached the slider rod or bar, C. Contact is made between the rod and the coil by means of a sliding contactor, composed of metal sleeve, S, and blade, B. The entire sliding contactor is free to move along the bar, its blade making contact with various turns of wire along the coil, as it moves along. The enamel insulation is scraped from the wire along the path of the blade to enable efficient contact to be made.

One side of the circuit is connected to the slider bar; the other side to the end of the coil (either end). Thus, it is seen that the actual amount of coil connected into the circuit is chosen by appropriately setting the sliding contact. The inductive value may be varied between that of a single turn and that of all the turns in the coil.

Actually, this wide range of induc-



Fig. 6. Iron-cored inductors.

tance is not obtained in practice because a considerable portion of the coil remaining unused is still in inductive relation with the used portion. This is known as *end effect*. The dead end acts to alter the inductance of the active portion of the coil, limiting the practical reduction of inductance. Somewhat better performance may be obtained by connecting the end of the unused portion of the coil to the open end of the slider bar to short-circuit the dead end, as shown by the broken line in Fig. 2. However, only a slight advantage is gained by this modification.

The dead end acts to reduce the Q of the slide-tuned coil drastically as its inductance is decreased. This effect becomes more pronounced as the maximum size of the coil is increased, being largest for large coils. It is not uncommon for the Q of slide-tuned coils of approximately 500 microhenries maximum inductance to drop from approximately 200 at full inductance to about 20 at nearly half inductance. Short-circuiting the dead end results in very little improvement in Q at this point, and further movement of the slider results in very little additional decrease in inductance. Performance is somewhat improved when the maximum inductance, and physical size of the coil, are lower. However, the Q curve exhibits a steep slope for any slide-tuned unit.

The leading disadvantage of the slide-tuned coil is the intermittent nature of its contact. The sliding blade tends to jump from one turn to another, being momentarily out of contact with the coil. This action gives rise to pronounced popping noises when attempts are made to incorpo-

Fig. 7. Variable shield sleeve inductor.



rate the slide-tuned coil in tube receiver circuits, and was chiefly responsible for the demise of its popularity when the crystal detector was abandoned. In transmitter tank circuits, where large values of radio-frequency current flow, this intermittent contact gives rise to heavy sparking which eventually wears away both the contact blade and the coil turns. In a number of experimental circuits, however, where the declining Q value and limited inductance variation may be tolerated, the slide-tuned coil offers a simple solution to tuning.

### Tapped Coil

Very similar to the slide-tuned coil is the tapped coil, illustrated in Figure 3. In this unit, a rotary switch takes the place of the sliding contact blade. The coil is wound with insulated wire, taps being brought out at appropriate points, in order that the switch may select various inductive

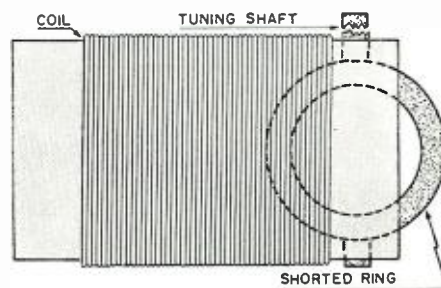

Fig. 8. Short-circuited ring type tuning.

values. In this type, as with the slide tuner, the actual coil size is adjusted.

The tapped coil, like the previously described type, possesses a Q curve that falls with decreasing inductance, however, the slope is not as steep as in the case of the slide tuner. The effect is particularly pronounced when the maximum inductance and physical dimensions of the coil are large. Nor is the effect reduced appreciably in large coils by shorting out the dead end. The most satisfactory and efficient tapped coils have low values of maximum inductance and small physical dimensions. However, these small coils are apt to be employed at high frequencies where switch contact resistance and other losses are apt to introduce additional difficulties to offset any advantage afforded by small size.

The following data was taken with a small tapped, air-wound coil. (Fig. 3): Full Coil; Q 278, L 0.014 mh. Three-Quarters Coil (Open Dead End); Q 280, L 0.013 mh. Three-Quarters Coil (Shorted Dead End); Q 238 L 0.0125 mh. Half Coil (Open Dead End); Q 205, L 0.0045 mh. Half Coil (Shorted Dead End); Q 173, L 0.0050 mh. One-Quarter Coil (Open Dead End); Q 188, L 0.0030 mh. One-Quarter Coil (Shorted Dead End); Q 161, L 0.0036 mh.

Like the slide tuner, the tapped coil introduces noisy operation in tube circuits, although this effect may be reduced somewhat by employing a wide  
(Continued on page 82)

# OHMITE

## RESISTANCE UNITS

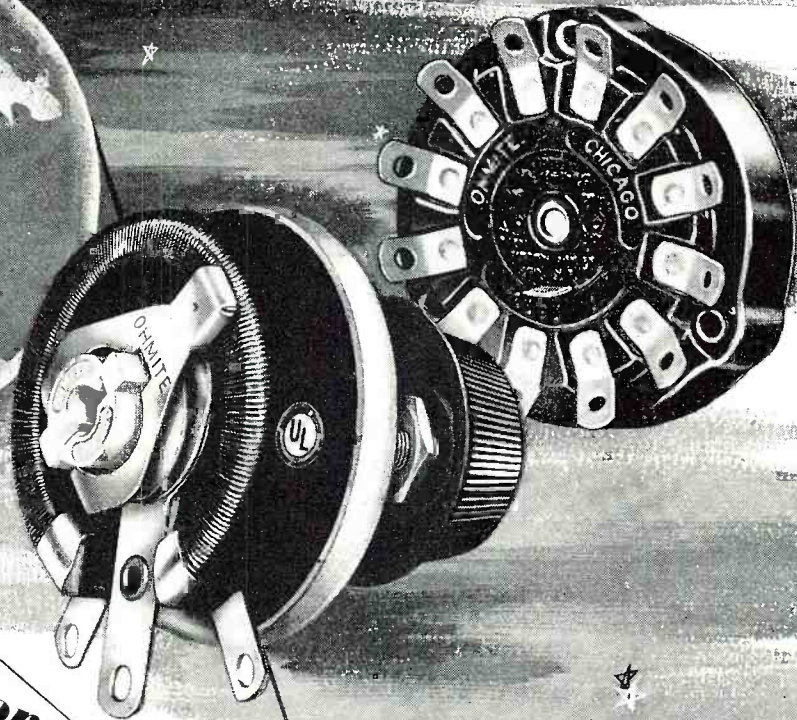

*Consistent Performance  
in Every Part of the World*

Years of world-wide service in all types of applications, under all kinds of operating conditions, have proved the sterling qualities of Ohmite Products. During this time, we have helped pioneer many applications of resistance units in electronic and electrical devices. As a result, we have developed and produced the widest range of types and sizes in power rheostats, resistors, and tap switches to meet every need.

Today, Ohmite Units serve in plant and laboratory—and on every battle front, from below the sea to the stratosphere, and from “down under” to the top of the world. Tomorrow, they will be ready and eager to meet new postwar requirements.

#### Send for Ohm's Law Calculator

Helps you figure ohms, watts, volts, amperes — quickly. Solves any Ohm's Law Problem with one setting of the slide. All values are direct reading. Send for yours — enclose only 10c in coin for handling and mailing.

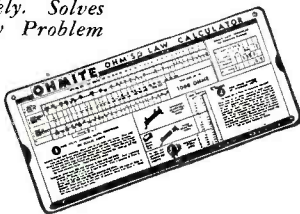

**OHMITE MANUFACTURING COMPANY**  
4884 Flourney Street, Chicago, U. S. A.



August, 1943



**I'LL SHOW YOU HOW TO GO PLACES IN RADIO MILITARY OR CIVILIAN TRAIN AT HOME . . . . or AT CAMP**

The greatest OPPORTUNITY that ever existed in Radio is open to you RIGHT NOW! Don't miss it! My practical Home Training will fit you quickly for a profitable Radio Repair business of your own . . . OR for a good-paying job in one of the Nation's Radio plants at work on equipment for planes, tanks, ships, etc. . . . OR for higher rating and better pay if you enter the Army, Navy or Marines.

**No Previous Experience Needed**

Sprayberry Training starts right at the beginning of Radio. You can't get lost. My tested and proved methods will get each subject across to you in simple, understandable style. Your success is my full responsibility. You learn Aviation Radio, Radio Set Repair and Installation Work, Mobile Radio (Auto-Tank), Television, Frequency Modulation, Signal Tracing, etc. You will be prepared to cash in on the coming great era of Electronics and Electronic equipment.



**Read What Graduate Says "Salary Has Increased!"**

"Since I have finished your Radio training I had to enlarge my laboratory with additional equipment, as I have all the Radio repair work that I can handle. My salary has increased to 50 to 75 dollars a week. I install transmitter equipment and public addressing systems. Money can not buy the training that I received through your Academy." Asa Smith, Post Box 528, Ft. Leavenworth, Kansas.

**Earn While You Learn**

Along with your Training, you will receive my famous Business Builders which can bring you in a nice profit shortly after you begin my Course. No matter if you remain a civilian or enter military service, my Radio Training will give you the background and knowledge to cash in on the marvelous future that lies ahead.

**EASY TO START . . .**

Remember it is not necessary for a Sprayberry student to have any previous experience in the field of Radio. You can master the Course in your spare time. It will not interfere in any way with your present duties.

GET THE FACTS ABOUT MY TRAINING—NOW! TAKE THE FIRST IMPORTANT STEP TOWARD THE MONEY-MAKING FUTURE OF YOUR DREAMS. ALL FEATURES ARE FULLY EXPLAINED IN MY BIG, ILLUSTRATED FREE BOOK. WRITE FOR IT AT ONCE.



**RUSH THIS COUPON for BIG FREE BOOK**

**DON'T DELAY! ACT NOW!**

SPRAYBERRY ACADEMY OF RADIO  
F. L. SPRAYBERRY, Pres.  
625-H University Place, N. W., Washington, 9, D. C.  
Please send me FREE copy of "HOW TO MAKE MONEY IN RADIO."

Name..... Age.....  
Address.....  
City..... State.....  
Tear off this coupon, mail in envelope or paste on penny postcard.

**Electronic Measurements**

(Continued from page 29)

Figure 4. Values in this illustration correspond to action of a self-generating cell with output of 450 microamperes per lumen. If such a cell is employed in the circuit of Figure 2 with a 0-1 d.c. milliammeter (average meter resistance of 33 ohms), response intermediate between the 3-ohm and 100-ohm curves will be obtained at 1000 microamperes (1 milliamperere). Full-scale deflection will thus correspond to approximately 140 foot-candles.

When extremely small values of illumination are to be measured, a d.c. amplifier (such as shown in Figure 1) may be interposed between the photocell and the indicating meter to provide higher sensitivity.

Aside from measuring actual illumination values as such, light meters have been employed in industry to determine the turbidity, and in some cases color of solutions to measure smoke density in stack and furnace control, and to measure the degree of surface polish in certain materials in terms of reflected light. It has also been employed in the testing, calibration, or adjustment of light-generating devices in line of production.

**Thickness of Non-Conducting Materials**

The thickness of non-conducting materials, such as paper, cellophane, and other sheet stock, may be determined by a double oscillator circuit, either continuously, as when the material is being automatically wound upon spools, or intermittently, as in sample testing. An arrangement for accomplishing this measurement is shown in Figure 5.

The apparatus includes a variable-frequency r.f. oscillator, a fixed-frequency r.f. oscillator, a mixer-audio amplifier circuit, and a beat-note indicator such as an audio frequency meter. In parallel with the frequency-determining L-C circuit of the variable-frequency oscillator is connected an external measuring circuit consisting of a two-element "measuring head." The head embraces two solid metallic members, a lower fixed electrode, over which the material passes in contact, and an upper movable electrode which rests upon the upper surface of the material but is free to move up and down as the thickness of the material changes. This measuring head is equivalent to an additional condenser, with the tested material as a dielectric, which is connected across the variable-oscillator tuned circuit.

As the material passes between the two electrodes of the measuring head, the changing capacitance will alter the frequency of the variable oscillator. If the fixed oscillator frequency is maintained near that of the variable oscillator, a beat note is set up and this is demodulated, amplified, and presented to the beat-note meter. Obviously, the capacitance of the

measuring head will depend not only upon the thickness of the material between its electrodes, but likewise upon the dielectric constant of that material. However, for a given material of uniform quality, the dielectric constant may be maintained fairly constant, so that the varying beat note, as the material passes through the measuring head, will depend most upon the amount of separation of the electrodes.

In operation, the material is fed into the measuring head, the portion actually resting between the electrodes being of the desired thickness. The variable oscillator is then set to zero beat with the fixed oscillator, whereupon the indicator reads zero. The material is then permitted to pass through the head, any change in its thickness causing a decrease in the head capacitance, a corresponding shift in the beat-note frequency, and a deflection of the meter. The meter may thus be graduated directly in thousandths of an inch or any other appropriate unit of measure.

Very often it is desired to show both plus and minus variations in thickness—that is, increases and decreases about a desired thickness. This may be accomplished by setting the beat frequency in the beginning to a value at mid-scale on the meter, rather than to zero beat. An increase in measuring-head capacitance will then cause an up-scale meter deflection, while a decrease in thickness will cause a down-scale deflection. The indicating meter may then be graduated in identical units of thickness on each side of a mid-scale zero, and the instrument will show whether the material is increasing or decreasing in thickness.

This same double-oscillator arrangement has been employed in other industrial measurements including the measurement of variations in dielectric constant of materials of uniform thickness, measurement of temperature coefficients of various conductors which are made a part of the measuring-head electrode assembly, and the determination of small weights. In the latter application, the lower electrode of the measuring head is rigidly mounted, while the upper electrode is supported by springs and is provided with a weighing pan. Increases in weight accordingly decrease the head-electrode spacing, increasing the capacitance of the assembly. By using a frequency indicator capable of showing a change of only a few cycles per second, and by employing highly-stable r.f. oscillators, weights and thicknesses of very small orders of magnitude have been successfully measured in industry. A few millionths of an inch has thus been detected.

**Detection of Metal Particles and Small Holes**

In the manufacture of certain insulating materials, such as condenser paper, insulating cloths and papers, and the like, the presence of small

ONE OF A SERIES OF ADVERTISEMENTS SHOWING DeJUR PRECISION PRODUCTS IN ACTION ON THE HOME FRONT

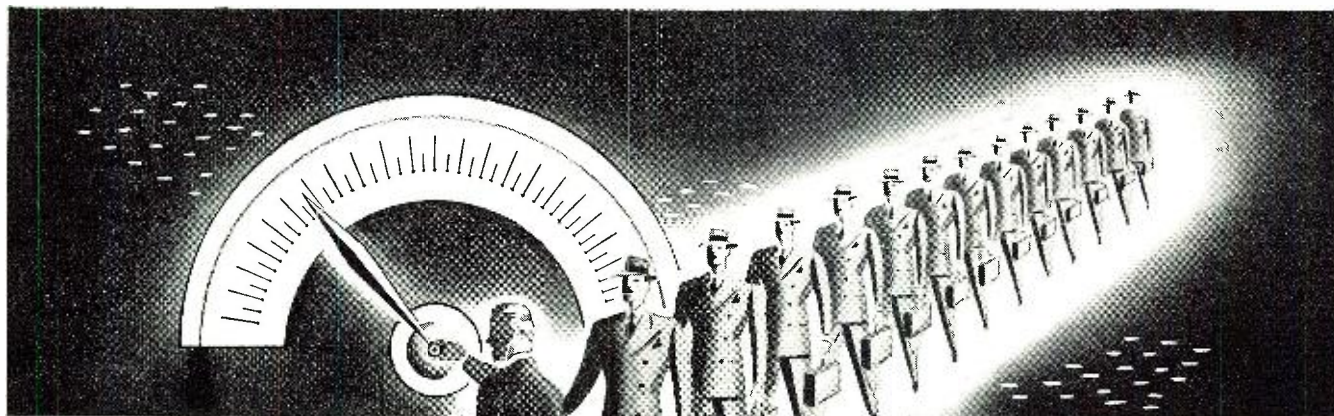

**IN GOOD WORKING ORDER...**

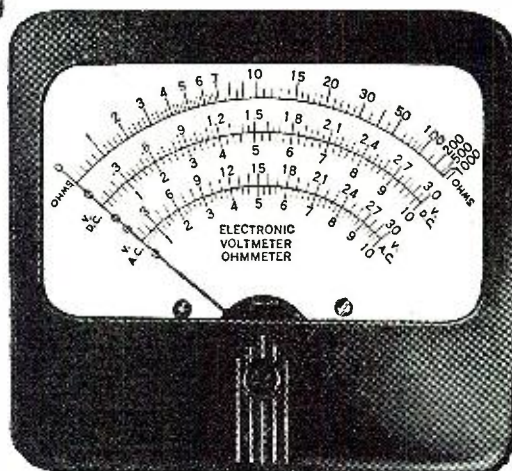

America is watched over by people... "little people" ... the policeman, the druggist, the shopkeeper, the repairman and so on. Bulking large in the life of the community these days is the radio serviceman... he's got to keep present sets operating for the duration.

Because his must be dependable equipment, you'll find that a DeJur Meter is the heart of his sensitive testing and checking apparatus. He has learned from long and constant use that this meter is consistently accurate, that it can take a lot of punishment, and that it can save precious time by enabling him to get to the bottom of the trouble immediately. For the fine job that the Radio Servicemen are doing in wartime America, the needle of the DeJur Meter points with pride.

*KEEP BUYING WAR BONDS AND STAMPS*



*Awarded for Excellence in Production and Quality of Material*

**DeJUR-AMSCO CORPORATION**

**SHELTON, CONNECTICUT**

**NEW YORK PLANT:** 99 Hudson Street, New York City • **CANADIAN SALES OFFICE:** 560 King Street West, Toronto



**“ABOVE  
and BEYOND  
the call of DUTY”**

Men of the Signal Corps are performing miracles in this war. Decorations are being presented to those valiant soldiers for performances “above and beyond the call of duty.”

And Murdock Radio Phones are their “ears.” Precision built “above and beyond” Signal Corps specifications, they are sensitive to scientific exactness, and dependable. See these unusual Radio Phones. Send to Dept. 45 for catalogue.

**Murdock**

**RADIO  
PHONES**

**Wm. J. Murdock Co.  
Chelsea, Mass.**

particles of metal in the material must be detected in routine inspection. These particles are very often so small as to be invisible to the eye of the inspector, or may be imbedded within the material.

An arrangement similar to the double-oscillator circuit of Figure 5 has been employed for this purpose. The presence of metallic particles in material of varying thickness (which passes between, but not in contact with the measuring-head electrodes) will cause abrupt changes in the meter deflection.

A simpler arrangement has also been employed. A radio-frequency detector circuit is set up near the passing material in such a manner that the material must pass very close to the frequency-determining coil. The circuit is usually adjusted to be on the verge of oscillation, so that the presence of a metallic particle will set the circuit into oscillation, trigger-fashion.

Opaque or dense translucent materials may be inspected for pinholes by means of a light source, photocell, and alarm circuit. The light source delivers a narrow beam which sweeps the material as it passes through processing machinery. The photocell is located on the opposite side of the material and is connected to an amplifier and a suitable alarm device, such as a bell, horn, or light. When a pinhole is located, the beam impinges upon the cell, setting off the alarm. By employing a rapid beam sweep and fast-acting cell, a maximum of area may be inspected as the material passes at a normal rate of speed.

This system is not so readily applicable to less dense translucent materials and may not be adapted at all to transparent materials such as celluloid, cellophane, etc. With dense materials, however, tiny apertures may be readily detected by employing a highly-sensitive photocell alarm circuit. For less dense materials, the sensitivity may be reduced somewhat by means of an appropriate gain control so that the alarm circuit will not be actuated by light seepage through the material instead of by direct rays through holes.

**Thickness of Surfacing**

The thickness of various surfacing materials on metallic surfaces may be checked electronically when the material is not readily checked by means of micrometers and similar gauges. An example is the thickness of paint or other insulating or protecting materials upon metal plates of large size.

The coated plate is made one electrode of a fixed condenser which is then connected in a suitable capacitance-measuring circuit of either the vacuum-tube, meter, or bridge type. A second exploring electrode, constructed of flatly-polished metal, is pressed tightly against the coated surface. From the active area of the exploring electrode, which is also connected to the measuring circuit, and the dielectric constant of the coating material, together with the capacitance



# TAYLOR TUBES



## *Efficiency in Action...*

As always, Taylor is building the finest tubes possible to produce. Every Taylor Tube is designed and engineered to deliver maximum service under strenuous battle conditions. Unfailing, "on the air" performance is their keynote—extra power for vital communications is their heritage. You can rely on Taylor Tubes. "More Watts Per Dollar" service in any situation.

*Taylor* HEAVY **CUSTOM BUILT** DUTY *Tubes*

TAYLOR TUBES INC., 2312-18 WABANSIA AVE., CHICAGO, ILLINOIS



# ON TO VICTORY!

**IT TAKES** stout, rugged men to fight a tank. The speed, the bucking and swaying, the paralyzing roar and shudder of gunfire continuously test stamina of both men and equipment.

Consolidated Radio is justly proud to be making headphones that are slugging it out with our fighting tank men...and coming through...the roughest, toughest battle conditions.



**Consolidated Radio's Modern Mass Production Methods Can Supply Signal Corps And Other Headphone Units In Quantities To Contractors.**

**CONSOLIDATED  
RADIO PRODUCTS CO.**

**SPECIALISTS IN MAGNETIC AND ELECTRONIC DEVICES**

**350 WEST ERIE STREET • CHICAGO, ILLINOIS**

obtained by measurement, the thickness may be calculated:  $t = kA/4.45C$ ; where  $t$  is thickness (inches),  $k$  is dielectric constant,  $A$  is area of exploring electrode (square inches), and  $C$  is measured capacitance (micro-microfarads).

The success of this measurement depends upon obtaining a tight bond between the exploring electrode and the surface of the coating material, in order to eliminate as much air dielectric as possible, and upon the maintenance of the shortest possible leads to the measuring instrument. The method may not be applied to surfaces having conductive properties.

-30-

## Color Comparators

(Continued from page 41)

regions are selected for measurement from the complex waveform and a measurement is made separately in each band of light reflected from the sample. The three readings give a complete account of the color.

The lamp at the bottom of the chamber is energized by the constant output of a voltage regulator. The light it produces passes through a lens system, one of the three color filters, the open center of the light-sensitive surface, through the viewing aperture, and strikes the test sample. The latter is "slightly out of focus" so as to receive diffused illumination over a relatively large area. The filtered light is reflected by the surface of the test sample to the light-sensitive surface which is so constructed as to integrate light arriving from a number of directions.

Separate meter readings are taken with the red, blue, and green filters in place. Two colors match precisely in hue, saturation, and brilliance when the meter deflections obtained successively with red, blue, and green filters are the same for the two samples.

In operation, the instrument is first standardized with a calibration sample of magnesium oxide, a white material; with the magnesia sample over the viewing aperture, meter shunts are adjusted for a reference deflection of the meter with red, blue, and green filters successively in place. Readings with each filter may then be taken with the test sample over the viewing aperture.

Still finer color inspection is possible by analyzing separately each of the components in a complex color waveform, evaluating each in terms of some satisfactory unit of intensity. A color analyzer for carrying out such an inspection has been designed by Hardy and manufactured by General Electric Company.

This instrument is comparable to the wave analyzer employed by radio engineers to explore a complex audio-frequency waveform and performs in an analogous fashion. The high degree of selectivity required for "tuning" to the various color wavelengths

# RONAME

## CAREFUL

LABORATORY CONTROL  
INSURES THAT EXTRA  
MEASURE OF QUALITY  
AND UNIFORMITY  
CHARACTERISTIC OF  
PARTS FABRICATED  
BY **GRONAME**  
A DEPENDABLE SOURCE

**CROWE NAME PLATE & MANUFACTURING CO.**  
PRINCIPAL OFFICE AND PLANT CHICAGO

NEW YORK  
ST. LOUIS

PHILADELPHIA

DETROIT

CINCINNATI  
LOS ANGELES



*Today this flag flies over*

**From this world headquarters for radio-electronic research flow new weapons, new discoveries and inventions vital to the winning of an Allied victory!**

**T**ODAY, over RCA Laboratories, flies a new distinguished battleflag—the coveted Army-Navy “E” Award.

One of the few laboratories in America to receive this award, RCA is at once proud of this distinction, and humbly aware of the responsibilities that it imposes. For much of the progress of the entire radio-electronic industry stems from the work done in these laboratories.

It was perhaps with this thought in mind that—at the dedication of the RCA Laboratories in Princeton—the Chief Signal Officer of the Army called them “The Hidden Battlefront of Research.”

**HIDDEN**—because, for the duration of the war, this magnificent building of 150 separate laboratories must be closed to all but the scientists and research technicians who are working on radio-electronic instruments important to our military effort.

**BATTLEFRONT**—because in the waging of modern warfare, radio-electronics is of first importance. It follows the flag and the fleet—locates the enemy—flashes urgent orders—safeguards the convoy—guides the bombers—directs the artillery—maneuvers the tank. This science fights on every front.

And when that certain day of Victory comes, RCA Laboratories will be devoted to the happier task of making our peacetime world richer, safer, more enjoyable and more productive—through new and finer products of radio, television and electronic research.

**OTHER SERVICES OF RCA WHICH HAVE EARNED OUR COUNTRY’S HIGHEST WARTIME AWARDS**



The Army-Navy “E” flag, with two stars, flies over the RCA Victor Division plant at Camden, New Jersey.



The Army-Navy “E” flag, with one star, has been presented to the RCA Victor Division at Harrison, New Jersey.



The Army-Navy “E” flag, with one star; also the U.S. Maritime Commission “M” Pennant and Victory Fleet Flag have been awarded to the Radiomarine Corporation of America in New York City.

*A Service of  
Radio Corporation of America*



**RCA**

**WORLD HEADQUARTERS**

**RADIO NEWS**

*America's Secret Battlefield*  
**RCA Laboratories**



*Laboratories*

**FOR RADIO-ELECTRONIC RESEARCH**

August, 1943

is provided by sharply-tunable optical filters.

The separate adjustments to individual wavelength components required in operating the color analyzer, and the time required to make these numerous settings make the analyzer unsuitable for rapid production tests such as color matching. And, for the latter type of inspection, the simple color comparator is highly satisfactory. The analogous condition is encountered at lower frequencies, where simpler distortion meters supplant the more complex audio wave analyzer for routine production operations demanding speed and economy with a minimum of operating skill.

-30-

### Army's SCR-299

(Continued from page 20)

found the 299 in trucks, fixed stations, and in other units which were broken down into components so that they could be flown over the "hump" (of the Himalayas) for use by our Air Forces in China under General Chennault. In fact, the General saw two of the SCR-299's being unloaded as his plane landed in China.

American radio engineers and military personnel will be interested to note some of the remarks made by various commands on this Signal Corps radio unit and its application.

The SCR-299 was used on five networks at the time our huge convoy landed in North Africa. These included circuits from Oran to England, Casablanca, Gibraltar, Algiers, and Accra.

General Olmstead, in a recent interview, said, "This set was picked as being outstanding because it performed admirably in applications other than those for which it was originally designed. It possesses much versatility and is so popular that the main difficulty is increasing orders to meet the demands from the various forces.

"The generator which goes along with the set in the trailer unit provides adequate power. We have seen cases where unusually long periods of continuous operating service have been had without failure."

Comments from a report made by Lieutenant Colonel A. A. McCrary, at a location which cannot be revealed, included the statement:

"The SCR-299 is a great set," by the Army Signal Corps Officer, 5th Army in North Africa.

Commanding General of one of the Infantry Divisions on the African front said: "It's a good set."

From the Commanding General of the 34th Division comes a report, "It is a mighty fine set. We have about all we need in this section."

The Chief of Staff of the 1st Armored Division has the following comment: "The 299 is a fine set. This set will give us all the range we need and more. Of course, at times we run into heavy static and can't get through—but no radio set would under those conditions."

In another report, the Signal Corps Officer of one of the Base Sections says the following: "The SCR-299 has been installed as a fixed radio station and is giving excellent results."

The Signal Corps Officer of the 1st Armored Corps, in a recent report included the following: "The 299 was used for a fixed point installation. It is an excellent set, very stable, and gives the necessary frequency range."

Major Pickett, prominent field officer, reports: "The 299 is a fine set and is giving excellent results."

These are only a few quotations from official reports. Military censorship does not permit any vital information to be released which would be of aid or comfort to our enemies. Therefore, until other battles are won and campaigns are completed, we cannot give "case histories" from other fighting fronts where this unit is giving superb service and where it is helping to win further "battles of communications!"

The American radio industry can well be proud that it and the Signal Corps have contributed an outstanding development comparable to that of the Flying Fortress, the Liberator, the Garand rifle, the "jeep" and the many other potent weapons which will inevitably aid in winning total Victory.

-30-

WHEN THE LIGHTS  
COME ON AGAIN...

MIRROR-TONE  
MIRROB-TONE

MADE BY THE MAKERS OF AUDIOGRAPH

FOR *Entertainment* IN THE HOME

Life again will be reasonably carefree and happy. When that time comes MIRROR TONE Recreating Phonographs will be available again, to entertain you in your home with music more faithfully mirrored than you have ever known. Thus, the hard lessons of today's experience will be translated into tomorrow's enjoyment.

JOHN MECK INDUSTRIES  
PLYMOUTH, INDIANA



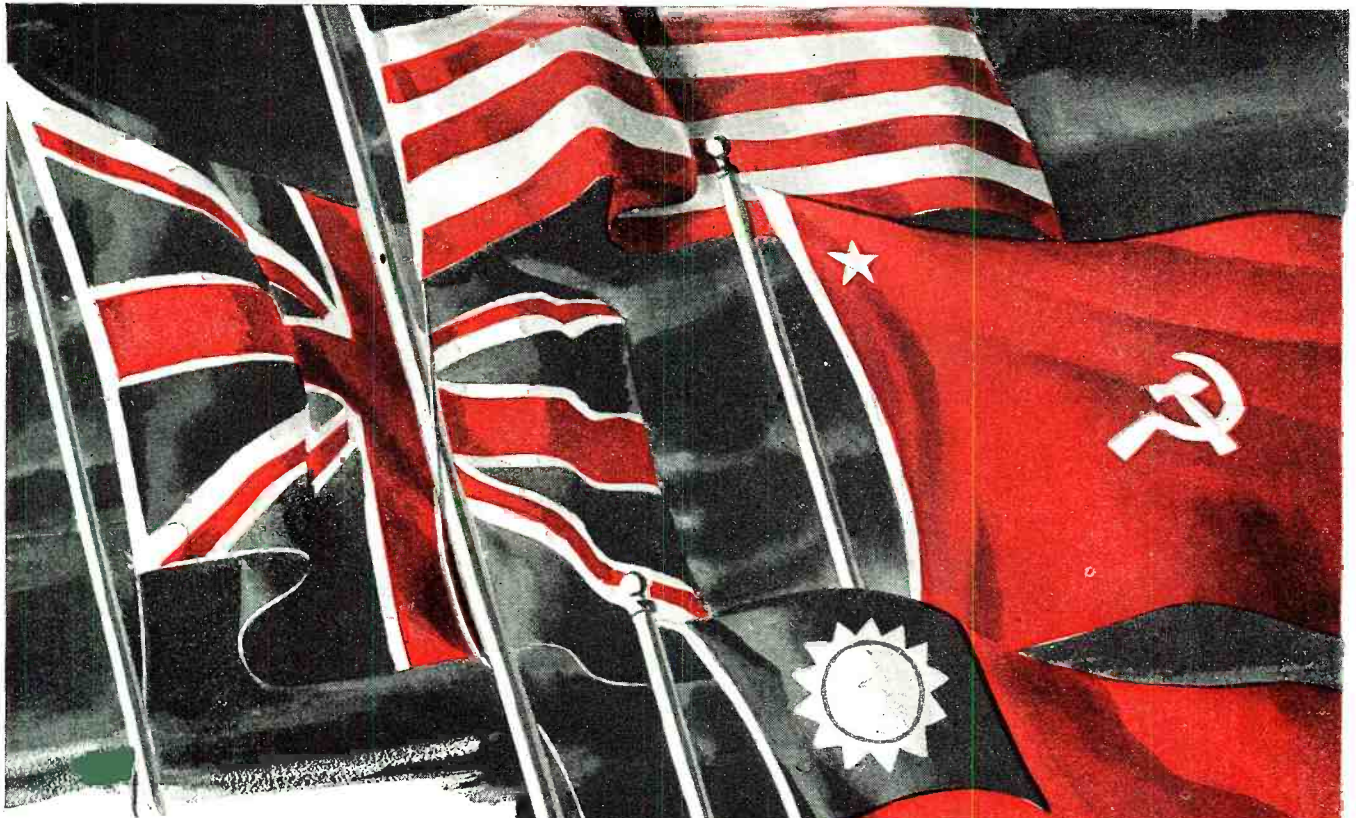

*the Hope*  
**OF THE WORLD**  
*today -*

**WILL BE THE REALITY  
OF TOMORROW**

American industry is working . . . and working hard . . . to keep the light of Liberty burning bright; not only for Americans, but for all men. Electronic Corporation of America realizes that the war is not yet won, but believes that it is not too early to make plans for the peace to come.

Electronic Corporation of America is now engaged in 100% war production of electronic devices and equipment . . . and is pledged to continue the all-out effort 'till the world is swept clean of Nazism. Then, but not until then, the whole world will know the direct benefits of American productive genius and engineering know-how in the field of electronics.

• *The engineering skill and modern mass production methods of ECA can supply electronic devices and equipment in quantities to manufacturers and government agencies. Your inquiries are invited.*

"Buy More—AND MORE—War Bonds"

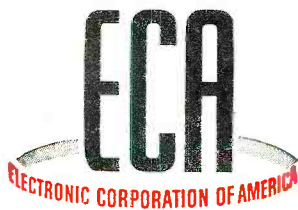

"LET'S WIN THE WAR NOW . . .  
WITH THE UTMOST IN PRODUCTION."

**ELECTRONIC CORPORATION OF AMERICA**

45 WEST 18th STREET, NEW YORK CITY . . . PHONE WATKINS 9-1870

# Winner OF COM

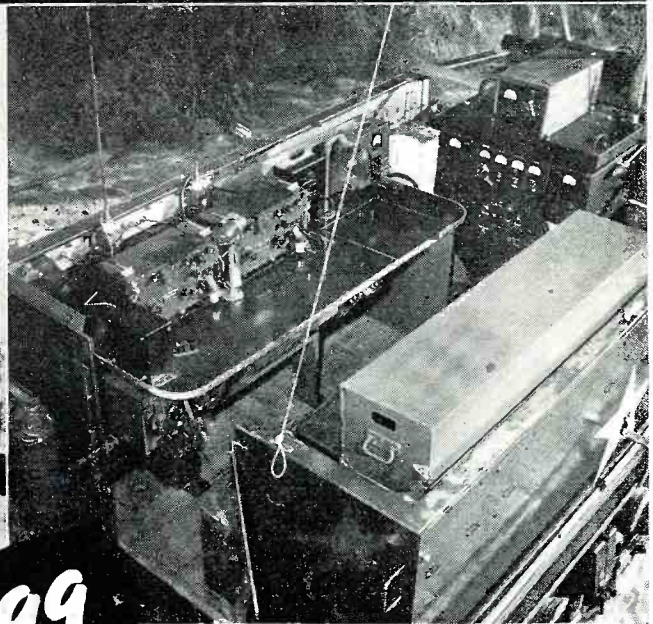
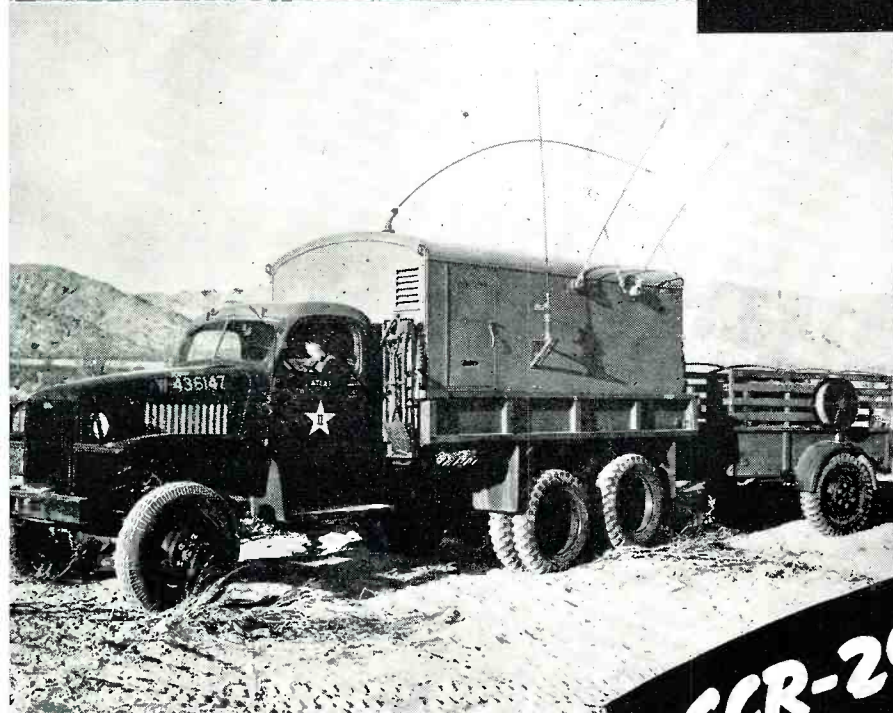

SCR-299

Mobile communications units assembled by Hallicrafters are helping to win the battle of communications on every fighting front. They are built to endure the rigors of modern warfare . . . The consistent performance of SCR-299 has been highly praised by lead-

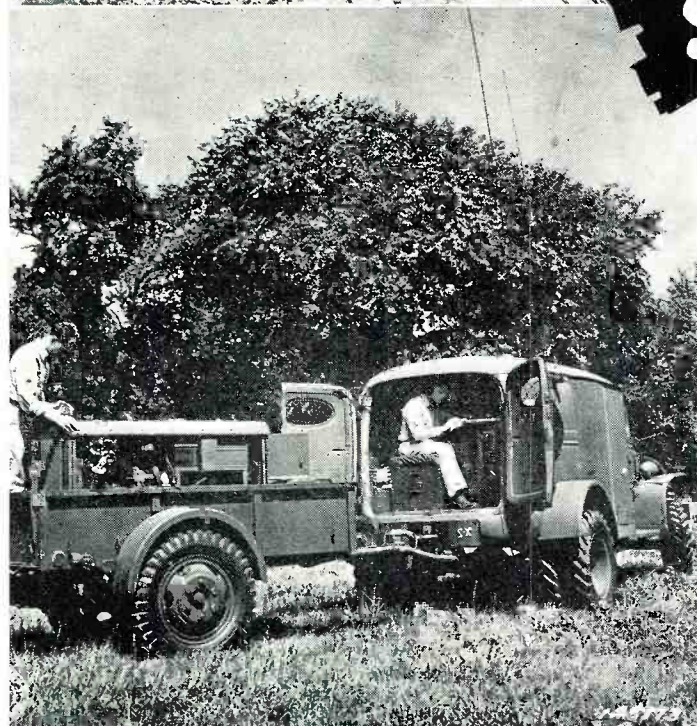

**hallicrafters**  
CHICAGO,

THE WORLD'S LARGEST EXCLUSIVE MANUFACTURERS



# *ing* "THE BATTLE MUNICIPATIONS!"

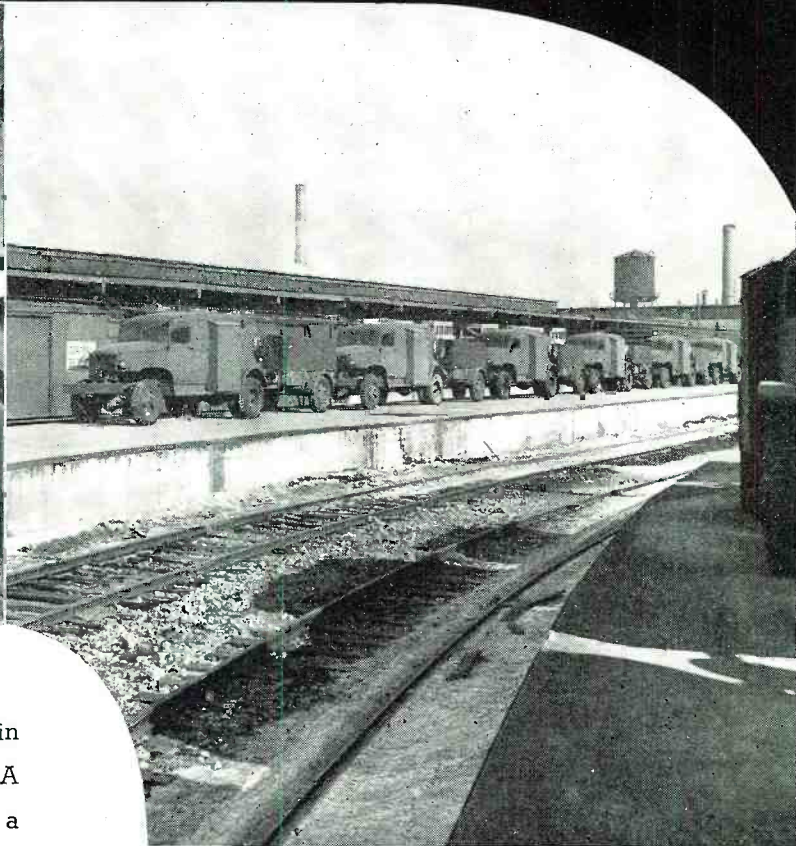
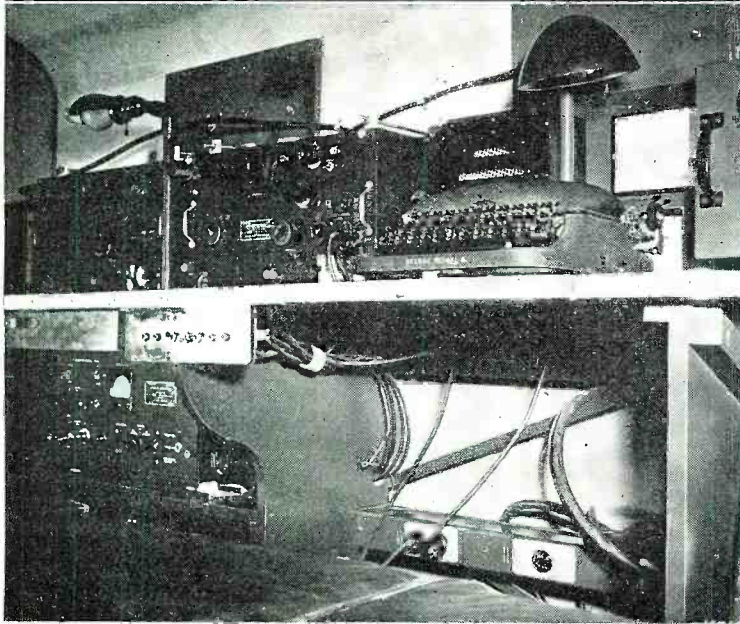

ing members of our armed forces for its adaptability in meeting all the requirements of combat duty . . . A phrase best describing the SCR-299 was given when a leading military authority said, "It is to communications what the jeep is to transportation."



**after**  
U.S.A.



BUY MORE BONDS!

OF SHORT WAVE RADIO COMMUNICATIONS EQUIPMENT

## Medical Apparatus

(Continued from page 36)

platinum needle that may be brought in contact with tissue. The extremely high current intensity at the point of needle contact is so great that considerable heat is produced and the tissue may be entirely destroyed. Small blood vessels, severed by such means during operations, are sealed normally by the heating action and considerable reduction in loss of blood is the result. There is no essential difference between the radio knife and diathermy equipment.

Above 10,000 cycles per second, the human being experiences only a sensation of heat when an electric current is passed through the body or parts of it. The value of current that the average person can stand at 60 cycles ranges from 3 to 10 milliamperes. At 10,000 cycles it may extend from 25 to 30 milliamperes, at 100 kc. it may range from 250-600 milliamperes. The frequencies widely used are 500 kc. to 1,000 kc. Diathermy apparatus must be licensed under new regulations of the government since such equipment can easily be converted into powerful sending apparatus. Its use in radio transmission is, of course, strictly forbidden.

Electrodes a couple of square inches in size are used to apply the treatment

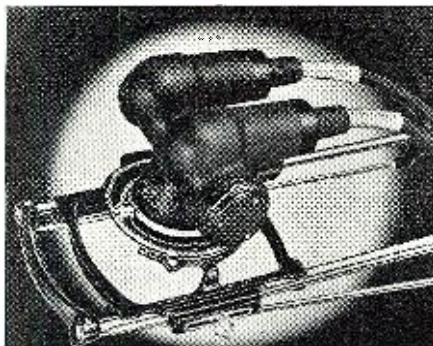

A Coolidge oil-immersed X-ray tube.

to an area uniformly. In clinical machines the patient may be placed in an electromagnetic field created by a powerful apparatus. It has been found that such treatment is beneficial in cases of syphilis, pleurisy and many other diseases.

### Types of High Frequency Medical Generators

The old spark coil transmitter used in the early days of radio represents one type and the other is a standard tube oscillator arrangement. In one type of diathermy apparatus a small, spark coil is mounted in a bakelite handle and electrodes of various sizes and shapes may be fitted into the end of the handle. Holding the handle in one hand, the electrode is touched to the body and then drawn off slowly. It is found that a bluish light is ob-

served and a sort of spitting, hissing noise is heard. The output of this type is varied by adjustment of the speed of the vibrator which is done by twisting a knob on the handle to the right or left depending on whether an increase or decrease is desired.

The usual service troubles that develop are: shorted or leaky condenser across the vibrator-contacts, open coil, broken leads or connections, dirty or pitted vibrator points which can be cleaned in much the same way as the interruptor of a car ignition circuit, or the contacts of a relay. The output of such a device may carry over a wide band of frequencies similar to a car's ignition system, having no tuned elements. In more elaborate apparatus tuned circuits may be used and the equipment is more bulky. Typical circuits are shown in Fig. 4.

The use of radio and electrical apparatus by men of medicine is continually increasing. The audiometer used in connection with fitting of hearing aids to deaf persons, the electrocardiograph for making a record of heart action, the encephalograph recently developed by Dr. Saxton Burr of Yale which permits measurement of brain currents and many other similar uses of electricity bid fair to make the world of tomorrow even more interesting and of greater scientific achievement than in the past.

-30-

# FADA Radio

## Now Fada Brings You Henry J. Taylor Over WJZ



As a public service to FADA owners, dealers and jobbers . . . as a service to all America . . . FADA brings you Henry J. Taylor five evenings each week over WJZ from 11:05 to 11:15 P.M.

Last American into Berlin . . . last American out of Germany before Pearl Harbor, Mr. Taylor is not only a successful industrialist . . . top-flight economist . . . famous war correspondent . . . world traveler . . . but author of current best-seller "Men in Motion."

Hard-headed, clear thinking comments are brought to you by one of the best informed men in America . . . completely personal and independent . . . his own views without restriction or censorship by FADA as his sponsor.

FADA takes pride in "going on the air" over one of America's leading stations . . . takes pride in bringing to you one of the clearest . . . most concise . . . hard hitting and direct interpreters of the news.

FADA brings you Henry J. Taylor purely as a public service . . . FADA has nothing to sell until the war is over. Today FADA men . . . machines . . . resources . . . priceless experience . . . are working 100% for victory for our Government and our Allies. When peace is won FADA will produce startlingly changed . . . simplified . . . improved radio/electronics . . . for you . . . post-war.

## FADA RADIO AND ELECTRIC COMPANY, INC. LONG ISLAND CITY, N.Y.

1920 SINCE BROADCASTING BEGAN 1943



# STANDING BY...

*to give our boys on submarine duty the "alert"  
warning... JENSEN marine speakers are  
living up to their quality tradition of consistent  
performance on missions that must not fail.*

**JENSEN**  **Jensen**  
JENSEN RADIO MANUFACTURING CO.  
6601 SO. LARAMIE AVE., CHICAGO



## GET NEEDED RADIO PARTS Quickly!

Don't allow *your* production lines to slow down for lack of essential parts. Lafayette Radio Corp. is headquarters for all radio and electronic parts and equipment of every nationally known manufacturer in the field. Let Lafayette help you keep your production humming and save *your* time—one single order to Lafayette will insure *prompt* delivery on all hard-to-get parts and equipment your program may require.

Thousands of manufacturers, electronic engineers and private and military training program directors know Lafayette's reputation for complete stocks and extensive procurement facilities. We can fill *your* needs too—*quickly!*

Write today for Free 130 page Radio and  
Electronic Parts and Equipment Catalog—  
Address Dept. 3E3



# LAFAYETTE RADIO CORP.

★ 901 W. JACKSON BLVD.  
★ 265 PEACHTREE STREET

CHICAGO, ILLINOIS  
ATLANTA, GEORGIA

### Practical Radio Course

(Continued from page 39)

harmonics is present, as we shall see later.

#### Conditions for Maximum Power Output

In order to analyze the operation of a power tube and ascertain the maximum power output obtainable (without regard to any distortion that may be produced) it is convenient to consider the typical output circuit shown at (A) of Fig. 4. Its equivalent electrical circuit is illustrated at (B). The power tube is shown supplying signal power to a load in its plate circuit when a signal voltage having an "effective" or r.m.s. value of  $e_g$  is applied to its grid circuit. While the load may be any kind of device to be actuated, in this case it is represented as the primary winding of an output transformer feeding a loudspeaker. In the equivalent electrical circuit shown at (B) the r.m.s. signal voltage acting on the grid is replaced by the a.c. signal generator whose voltage is acting directly in the plate circuit; where  $\mu$  is the amplification factor of the tube. The internal a.c. plate resistance of the tube is shown as  $R_p$  and the impedance of the plate circuit load is  $R_L$ .

The amplitudes of the current changes in the plate circuit are equal to the amplified voltage changes ( $\mu e_g$ ) acting in the plate circuit divided by the total resistance and impedance in the plate circuit, thus:

$$I_p \text{ (change)} = \frac{\mu e_g}{R_L + R_p}$$

This varying current  $I_p$  flowing through the load resistance  $R_L$  produces a change of voltage  $E_L$  acting across the load resistance, or

$$E_L = I_p R_L$$

Substituting the value  $I_p$  in the previous equation for  $I_p$  in the foregoing equation we obtain:

$$E_L = \frac{\mu e_g}{R_L + R_p} \times R_L = \frac{\mu e_g R_L}{R_L + R_p}$$

The power in watts ( $P = E \times I$ ) expended in the load impedance (considered as resistive) is equal therefore to the product of the r.m.s. values of this current and voltage. Hence the power output is:

$$\begin{aligned} \text{Power Output} &= \frac{\mu e_g}{R_L + R_p} \times \frac{\mu e_g R_L}{R_L + R_p} \\ &= \frac{R_L \mu^2 e_g^2}{(R_L + R_p)^2} \end{aligned}$$

This equation is fundamental for all vacuum tubes, assuming the tube to be operating on the straight part of its characteristic; i.e., that the plate and grid voltages are properly adjusted.

The power output for any given sig-



# You are going to be a bigger man

Keep this fact clearly in mind: *electronics* is the growing art of harnessing electron tubes—in many cases, familiar types of radio tubes—to new applications; and it means everything to your future.

Big as the radio and communications industry has been, it is only *one phase* of electronics. Hitherto your opportunities have been practically limited to that one phase—transmission of sound. At the start of the war, television—transmission of sight—was just opening up.

When the war is over, television will arrive—but *it won't be alone*. RCA electron tubes will be put to work on thousands of *new jobs*—new electronic devices.

As a Tube and Equipment Distributor and Serviceman *YOU* will service these devices—sell replacement tubes they will require.

*YOU* will draw income from this vastly widened field. You will be a *bigger man*—expanding, reaching out, grasping opportunity. RCA Engineers and RCA Tube and Equipment Distributors and Servicemen, working together, can help enormously to make electronics the biggest industry, and the greatest public service, this country has ever known!



## RCA ELECTRON TUBES

RCA Victor Division • Radio Corporation of America • Camden, N. J.



nal input voltage is a *maximum* when the a.c. plate resistance  $R_p$  and the load resistance are equal (that is, when  $R_p = R_L$ )\*. For example, a type 45 triode power amplifier tube which has an a.c. plate resistance  $R_p$  of 1,750 ohms will supply *maximum* power output for any given input signal voltage when the load resistance  $R_L$  is also 1,750 ohms. Under this special circuit condition, the power output equation just derived reduces to:

Maximum Power Output =

$$\frac{\mu^2 e_g^2}{4R_p} = \frac{(\mu e_g)^2}{4R_p}$$

If this equation is to be expressed in terms of *peak* signal voltages, then

remembering that the effective or r.m.s. value of a voltage or current equals 0.707 times the maximum or peak value, or equals the maximum value *divided* by the square root of 2, the expression becomes:

$$\text{Maximum Power Output} = \frac{(\mu E_g)^2}{8R_p}$$

where the *Maximum Power Output* is that obtainable when a signal voltage having a peak value of  $E_g$  is applied to the grid circuit of the tube.

This equation shows that the maximum output obtainable from a power tube depends not only upon the mu ( $\mu$ ) and a.c. plate resistance of the tube, but also upon the magnitude of

the a.c. signal voltage applied to its grid circuit. This, of course, demonstrates the necessity for the use of *voltage* amplifiers ahead of the power amplifier to build up the signal voltage before it is applied to the control grid of the power tube.

Since it is desired to obtain from a power amplifier tube the greatest possible amount of *undistorted* signal power output for a given applied signal voltage, it is convenient to compare the merits of power tubes on the basis of the relationship between power output and input signal voltage. This relationship is called the *power sensitivity* of the tube.

$$\text{Power sensitivity (mhos)} = \frac{\text{power output (watts)}}{\text{(r.m.s. input signal volts)}^2}$$

Thus, a power tube delivering 8 watts output when an input signal of 10 volts r.m.s. is applied, has a power sensitivity of  $\frac{8}{10^2} = \frac{8}{100} = 0.08$  mhos.

In general, pentode type power amplifier tubes have a much greater power sensitivity than do triodes. For example, when the 6L6 tube is operated as a pentode (strictly speaking, it is a screen grid tetrode so designed that the secondary emission is suppressed so it operates like a pentode), it consumes about 22 watts in its plate and screen circuit and, with a 14-volt signal applied to its grid, delivers 6.5 watts to the load. Now, when the screen is tied to the plate the tube becomes a triode. When so connected and the same value of plate voltage is applied, the 6L6 tube uses 10 watts in its plate circuit and, with a 20 volt signal applied to its grid, delivers only 1.4 watts. Even though the triode arrangement consumes but half as much power in the plate circuit, it requires about  $\frac{1}{3}$  more signal voltage to produce less than 25% as much signal power output. In other words, a pentode-connected 6L6 tube when employed in proper circuits will deliver more than four times as much power to the load with a signal voltage only  $\frac{2}{3}$  as great as required by the same 6L6 tube connected as a triode. This simply means that the power amplifier pentode tube has a greater power sensitivity than the triode. The practical advantage is that less voltage amplification is required preceding a power amplifier tube having high power sensitivity since it does not require as much input signal voltage for a given signal power output. Of course, other considerations such as allowable distortion, etc., might overbalance this advantage of the pentode for some applications.

## MEISSNER RADIO KITS ARE DESIGNED FOR QUICK TRAINING!

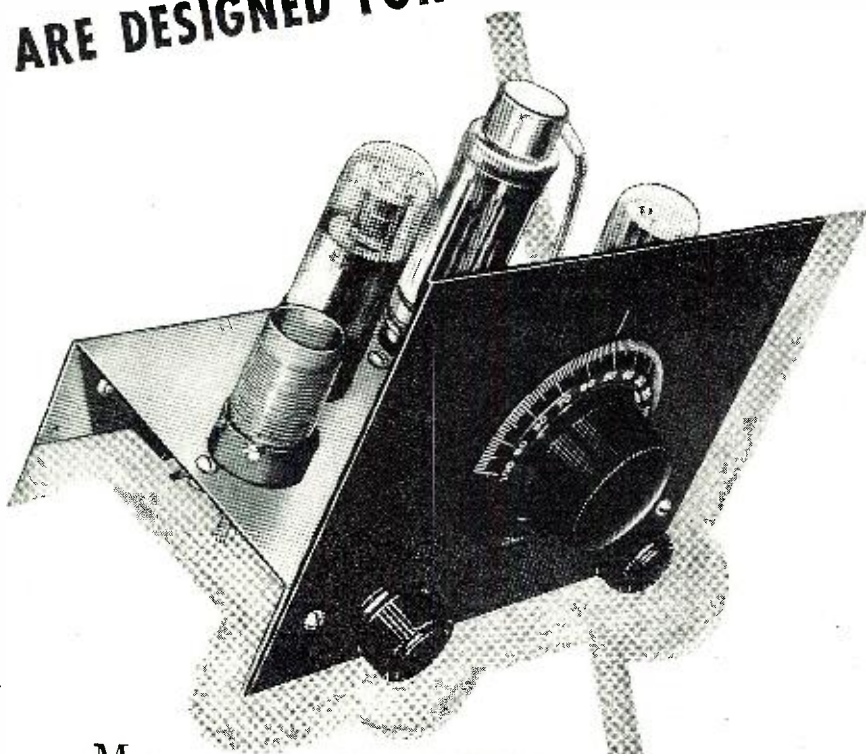

Meissner one, two and three tube Student "Midget" Kits solve the problem of quicker radio training. The Kits are especially designed for classroom use. The "add-on" feature permits the conversion of the one tube to a two tube and the two tube to a three tube receiver. Meissner Student "Midget" Kits are being widely used in schools for defense radio training.

**SIMPLIFIED CONSTRUCTION!** Meissner wiring diagrams enable the beginner to quickly assemble the Kit and give better results in basic radio instruction.

See your Meissner distributor or write.

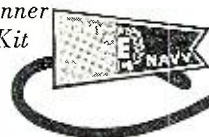

MT. CARMEL, ILLINOIS

**"PRECISION-BUILT ELECTRONIC PRODUCTS"**

\* For a mathematical proof of this, see any textbook on the fundamentals of radio, such as the author's Radio Physics Course.

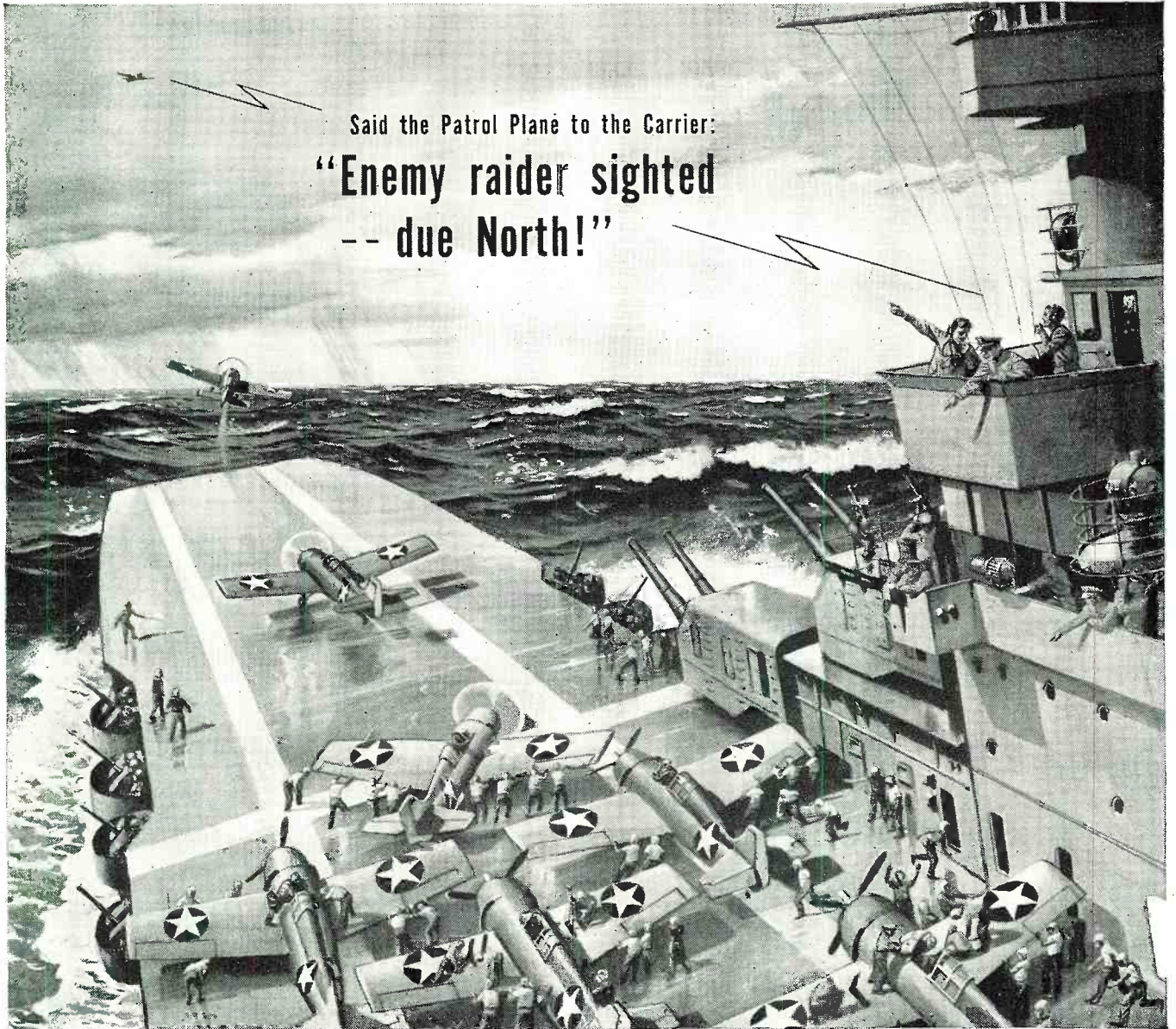

Said the Patrol Plane to the Carrier:  
**“Enemy raider sighted  
 -- due North!”**

They work together better . . .  
 because they can talk together

The streaking  
 Reconnaissance plane  
 Can't wait  
 Until its wheels touch  
 The lifting flat top  
 To tell its news . . .

While still  
 Only a growing shape  
 Over the horizon  
 This homing eagle  
 Calls to the mother ship . . .  
 Summons its brother warbirds  
 To the kill . . .  
*By radio.*

In a matter of minutes  
 The whole angry brood  
 Will swarm down  
 And polish off  
 The fleeing cruiser that

Just a few seconds before  
 Was a threat  
 To our bridge of ships . . .

Seconds count  
 In this thundering war  
 Of time and teamwork . . .  
 And seconds are saved  
 By the radiotelephone.

Today, modern radio equipment  
 Designed and manufactured  
 By I.T.&T. associate companies  
 Is helping Uncle Sam's fighting forces  
 Work together  
 On land, sea, and in the air . . .

Tomorrow, the broad experience  
 Of I.T.&T.  
 In the field of communications  
 Will help men build  
 A better world.

**INTERNATIONAL TELEPHONE AND TELEGRAPH CORPORATION** 67 Broad St., New York, N. Y.

**I T & T**

*Manufacturing Associate:*

FEDERAL TELEPHONE AND RADIO CORPORATION

## War by Radio

(Continued from page 37)

drew a picture of future battles where squadrons of tanks would roar into the attack, guns blazing, without crews. They would be controlled by wireless by operators in remote control dugouts far from the scene of battle. Television would enable the operators to follow the course of the battle and alter their tactics accordingly.

Lord Birkenhead's predictions were not based on fantasy. Shortly after

the last war the Great Powers had begun experimentation in *telearchics*—the remote control of mechanisms by wireless. The strides made in this field have been phenomenal.

As early as 1939 flights of more than a hundred miles had been made in the United States without the hand of a human pilot touching the controls. In France small planes went through complicated maneuvers guided entirely by wireless from the ground. It was a step from the use of the Sperry gyroscopic stabilizer—"automatic pilots"—to the wireless operation of the automatic pilot from the ground.

In 1935, the wireless-controlled Queen Bee, flying at more than 100

m.p.h., rising to a height of 10,000 ft., was introduced by the R.A.F. for gunnery practice. Seven white keys before the wireless operator on the ground was all that was manipulated in directing the plane. The "human factor" had been all but eliminated in flight.

The next step was obvious. If planes—and tanks and guns, for the principle of wireless control was the same in all cases—could be operated by remote control, why was it not possible for them to carry bombloads to targets, release them and fly back?

In September, 1940, Dr. Lee de Forest, brilliant American wireless experimenter, announced that a pilotless "television torpedo" plane was in the making. The plane would be made from plastics requiring no expensive armour-plating, as it would carry no personnel. Television cameras would be placed in the nose of the plane and a television transmitter would flash back to the control point a full picture of the changing scene as viewed from the plane. The operator could then maneuver the aircraft to perform its work of destruction.

Several months later, before America's entry into the war, American experts had achieved the pilotless bomber, a robot plane which could take off, fly to the target—the distance was limited only by the wireless frequency range and the fuel capacity of the aircraft—discharge its bombs and return to its base. For long-distance flights a fleet of robot planes could be "chaperoned" by a piloted aircraft which would control the movements of the robot squadron.

Meanwhile, wireless control of mechanized ground equipment, water craft, and artillery was rapidly being developed. Amateur experimenters, as always, made their valuable and distinctive contributions.

In New York I watched model ships maneuver into battle formation, aim their guns and fire at targets by remote control.

At the National Model Championship meeting held in Chicago in July, 1941, model aircraft went into power dives, pulled out, looped-the-loop and normally behaved as if they were being piloted by the most skillful of pilots.

A model plane climbed to 1,500 feet, power-dived to a few yards of the ground, climbed back in a steep ascent and went gracefully through a series of figures-of-eight before landing—all by remote control.

One of the chief problems confronting radio engineers in the development of wireless warfare was the interference which would be used by the enemy in frustrating our own wireless control.

Conceivably, enemy engineers would pit their wits against Allied design to "tangle" wireless controlled mechanisms. Highly complex mathematical battles could be fought over the radio waves for control of vast assemblies of robot tanks and aircraft operating in the No Man's Land of the ether.

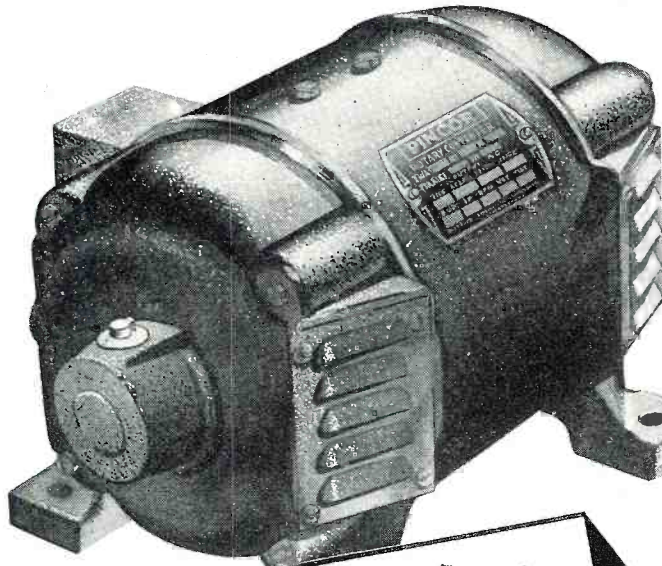

**Keep 'Em Running  
FOR THE DURATION!**

It is difficult to secure new Generating Sets or new Rotary Converters... Pioneer is devoting all of its resources toward winning the war... but we can, and will, help you keep your present equipment running for the duration.

Send your service problems, by letter, to Pioneer's Customer Service Department.

DYNAMOTORS • CONVERTERS • GENERATORS • DC MOTORS • POWER PLANTS • GEN-E-MOTORS

**PINCOR Products**

**PIONEER GEN-E-MOTOR**

CHICAGO, ILL. • EXPORT ADDRESS: 25 WARREN ST., NEW YORK CITY  
CABLE ADDRESS: SIMONTRICE, NEW YORK

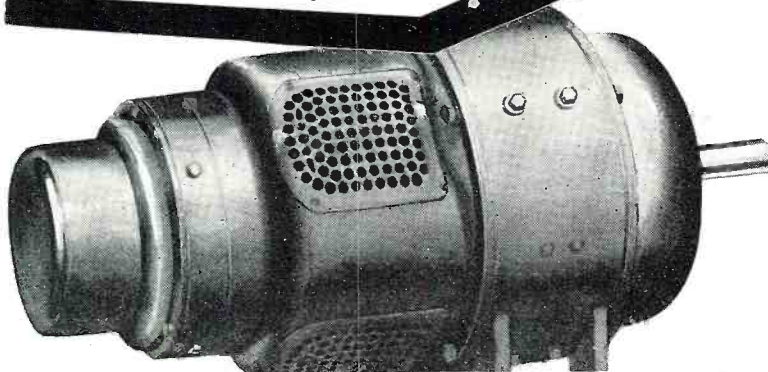



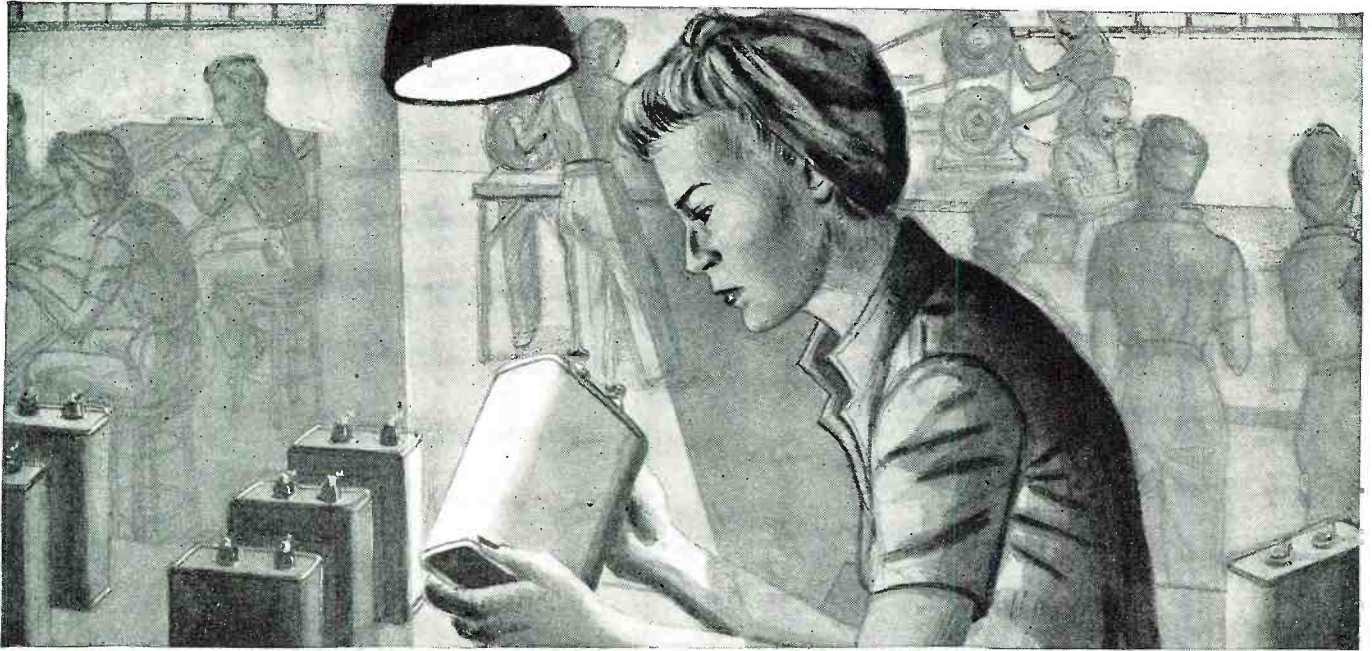

**MICAMOLD'S POSITIVE**  
*Leak Detector*  
**Assures Dependable**  
**Oil Impregnated Capacitors**

Manufacturers who use *Micamold Oil Impregnated Paper Capacitors* are assured that they are thoroughly leak-proofed at our factory. This is done by means of our *positive* "Leak Detector" . . . an ingenious silent watchman which definitely points out any leaks or defects. It must be "true" before it leaves the plant. *Micamold* dependability is a factor you cannot afford to overlook. Communicate immediately . . . and we'll send a representative to discuss your capacitor problems.

**MORE**  
*Keep buying War Bonds*



*Remember . . .*  
**There's a Micamold**  
**Capacitor for Every**  
**Communications and**  
**Electronic Application:**

- MOLDED PAPER CAPACITORS
- DRY ELECTROLYTIC CAPACITORS
- MOLDED WIRE WOUND RESISTORS
- OIL IMPREGNATED PAPER CAPACITORS
- RECEIVING AND TRANSMITTING MICA CAPACITORS

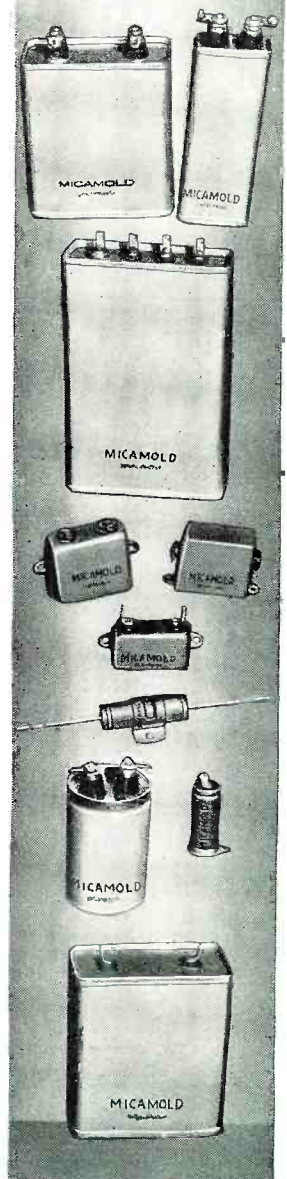

**MICAMOLD RADIO CORPORATION**      **1087 FLUSHING AVE.**  
**ION**      **BROOKLYN, N. Y.**  
 August, 1943

This problem of interference has been tackled with considerable success, and the danger of radio-controlled mechanisms turning against their creators has been partly solved, although insurance against "Frankenstein" disasters must still be perfected.

The guidance of aircraft by the radio beam has long been an established fact. The landing of aircraft in all kinds of weather has reached a high stage of perfection since 1938, when the radio beam method was introduced in American aviation.

At that time Mr. Louis Johnson, Assistant Secretary of Air, said: "We will be able to take off and land under conditions of zero visibility. In all kinds of weather we will be able to use the flying machine both as a military weapon and as a commercial carrier. Today 50 per cent of all air accidents are attributed to bad weather. Tomorrow, with the aid of this new automatic device, we will go far toward the conquest of the fog and the storm and the elimination of the hazards that the hostile elements carry."

Tomorrow is here. The air is interlaced with invisible roadways of radio beams as definite as if they were made of concrete.

-30-

**BUY  
War Bonds and Stamps**

## Manufacturers' Literature

(Continued from page 37)

equipment in the field of operations.

This handy booklet includes color code information on resistors, condensers, power and audio transformers, IF transformers, and speaker lead and plug connections. An additional feature is a conversion table of fractional inches to decimal and millimeter equivalents.

Immediate shipment can be obtained on orders sent to *Allied Radio Corporation*, 833 West Jackson Boulevard, Chicago, Illinois.

### RCA VICTOR ISSUES MORSE CODE ALBUM

A modern, streamlined system of instruction in the International Morse Code has been incorporated in a six-record album which Victor is releasing this week.

Prepared by John N. Cose, Director of Instruction at the *RCA Institutes*, the album and accompanying booklet are designed to acquaint students with the actual sound of the morse code letters as they would be sent over the air and to provide them with specially prepared practice transmissions which should develop the students' ability to copy regular code messages.

A novel feature of the morse code album is the incorporation of instruc-

tions on the records themselves, with the handbook as a check on all practice messages transmitted.

The first 8 lessons are devoted to alphabet instruction and special practice in letters introduced. Following intensive instruction and practice in the 26 letters, the album moves on to a study of coded five-letter groups, longer plain English words, sentence structure, "hard to memorize" English transmission, and winds up with a practice session of five-letter cipher groups using all the letters of the alphabet in unfamiliar combinations.

Vocal instruction disappears gradually throughout the album, leaving the last records almost completely devoted to code practice work. Two stumbling blocks in code instruction, memorization and anticipation of contents by the student, have been overcome by use of code and cipher groups which form unrecognizable words.

The war has created an unusual demand for code instruction, with the armed forces calling for trained signal men and the U. S. Signal Corps sponsoring training schools all over the country. The new Victor code album may be used as a valuable supplement to these code training courses.

### GHIRARDI RADIO TROUBLESHOOTER'S HANDBOOK

The tremendous popularity of the *Ghirardi Radio Troubleshooter's Handbook* has made it necessary to bring out a revised and enlarged 744-page edition—the third—of this practical and authoritative volume. It is new—complete—vital—a veritable gold mine of profitable information helpful in all phases of radio service work and designed to enable both new and experienced technicians to troubleshoot and repair all types of radio receivers faster and for greater profit under present "wartime" emergency servicing conditions.

Featured among its 744 manual-sized (8½" x 11") pages now are 404 pages of trouble "Case Histories" giving all the common troubles and their remedies for over 4,280 receiver and automatic record changer models—the largest authoritative "Case History" compilation ever published; a complete tabulation of I-F peaks and alignment data for practically every known superhet receiver; the most complete tube characteristics and biasing data chart ever published anywhere.

This big new Revised Edition is bound in handsome wear-resisting blue cloth with a stiff cover specially designed to stand constant handling in the shop. To really appreciate its completeness and merit, every service man should examine a copy for himself—page by page. The price is \$5 in the U.S.A. Copies may be obtained from your regular jobber or direct from Radio & Technical Publishing Co., 45 Astor Place, New York City, publishers of "*Ghirardi*" radio books.

-30-



Here, at Doolittle, we are coordinating every effort and skill to help provide the communications equipment so essential for Victory. This will mean better peace-time communications after our battles are won.



To Assure Victory  
Buy More U. S. War  
Bonds and Stamps

**Doolittle**  
RADIO, INC.

Builders of Precision Radio Communications Equipment  
7421 S. Loomis Blvd., Chicago, U. S. A.

*Their guns were loaded and aimed...yet*

## **ELECTRONICS FIRED THE FIRST SHOT**

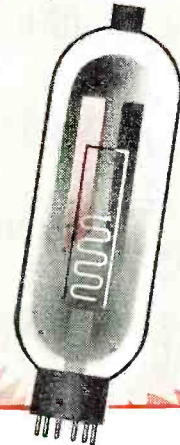

*On Sunday, November 8,*  
in North Africa, the sound  
which broke the peaceful still-  
ness of that eventful night was  
not the booming of allied guns,  
nor the throbbing engines of  
countless landing barges. It was  
a VOICE—the friendly voice  
of the President of the United  
States saying “We come among  
you to repulse the cruel invaders  
—Have faith in our words—  
Help us where you are able.”

*At many points where our boys landed along the North African coast there was little, if any, resistance because electronics had already won the day. By short wave radio America's motives had been made clear. Days of fighting were avoided. Thousands of lives were saved.*

This historic military achievement and many others on today's world battle fronts have won the electronic tube a place among the great weapons of modern warfare. Yes, electronic tubes can *fight!* And to supply these fighting tubes for our fighting forces the men and women of National Union have doubled and *redoubled* production. We know the day is coming when these tubes and the knowledge and

skill which build them will be reconverted to the needs of peace. In National Union's plans for this new age of electronics that lies ahead, your job, as a service engineer, will be more important than ever before. All that you'll need to gear up your business to this bigger job—tubes, test equipment, guidance in servicing and selling—National Union will have ready for you at the word “go”.

**NATIONAL UNION RADIO CORPORATION • NEWARK, NEW JERSEY • LANSDALE, PA.**

# **NATIONAL UNION RADIO AND ELECTRONIC TUBES**

Transmitting Tubes • Cathode Ray Tubes • Receiving Tubes • Special Purpose Tubes • Condensers •  
Volume Controls • Photo Electric Cells • Exciter Lamps • Panel Lamps • Flashlight Bulbs

# Now—A Tiny Power Supply Unit Weighing Only 34 Ounces

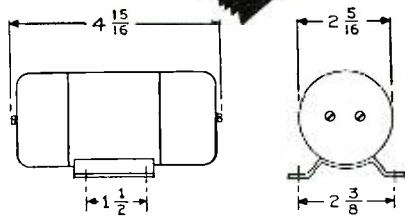

OUTPUT		INPUT		EICOR PART NO.
VOLTS	AMPS	VOLTS	AMPS	
200	.050	28	1.0	2316-21
		14	2.0	2316-22
150	.067	28	1.0	2316-23
		14	2.0	2316-24
100	.100	28	1.0	2316-25
		14	2.0	2316-26

Continuous duty. 50°C temperature rise.  
Regulation 20% from no load to full load.

Here is Eicor's answer to your need for a power supply that is much smaller, much lighter, and completely dependable. This tiny Dynamotor is now available to manufacturers of electronic equipment for critical applications where space and weight requirements are of utmost importance.

**SAMPLES AVAILABLE**  
Our specialized experience can be of help to you. Samples of this exclusive Eicor product in the types listed at left furnished quickly for development purposes on priority order.

Write, wire or phone

**EICOR INC.** 1501 W. Congress St., Chicago, U. S. A.  
DYNAMOTORS • D. C. MOTORS • POWER PLANTS • CONVERTERS  
Export: Ad Auriema, 89 Broad St., New York, U. S. A. Cable: Auriema, New York

## For the Record (Continued from page 4)

As this device is capable of removing all types of interference from radio receivers, the chief advantage of AM would be that of obtaining a higher fidelity for musical programs—which brings us to the second question: how many people really appreciate so-called high fidelity? We have talked to many of our friends and associates in recent months and find that, in most cases, the average listener will always make use of the tone control to reduce the normal range of the higher frequencies.

The first loud-speakers were over-abundant in highs. In later years there appeared on the market large console receivers which possessed an over-abundance of bass. Most people welcomed these new sets and found the listening a bit more comfortable and less irritable.

As time went on, a happy medium was found for the reception of treble and bass frequencies and a more even balance was found in the better receivers. There still was a tendency, however, to accentuate the bass frequency by artificially reducing the treble. Even today most people prefer their sets to operate in that fashion. Many become irritated from the extreme high treble notes received on FM sets. We do not seek to discredit the advantages of FM. However, with the new static eliminator the broadcasters of AM will be assured that their programs will be received satisfactorily, even by rural listeners. Furthermore, the greater coverage of AM will still be an advantage over FM transmissions.

Only time will tell just how successfully this new system will work and how far it will go to satisfy postwar radio listeners!

**HUNDREDS** of complimentary letters are being received on the recent *Aviation Communications* issue of RADIO NEWS. A few of them appear on Page 95. We are proud to have been able to make such a contribution to the war effort by presenting the complete story on the part that radio is playing in making possible the huge bomber attacks on our enemies and to show the many branches of service and other organizations upon whom rests the responsibility of "getting the message thru."

**WE** are happy to announce the addition of Mr. K. R. Porter to our RADIO NEWS staff. Mr. Porter, now an accredited correspondent, has left this country for Europe where he will gather factual information on the part that radio plays in winning the battle of communications. Formerly affiliated with the Office of Technical Information, *Special Activities Branch* of the U. S. Army Signal Corps, Mr.

# The SPRAGUE TRADING POST

EXCHANGE — BUY — SELL

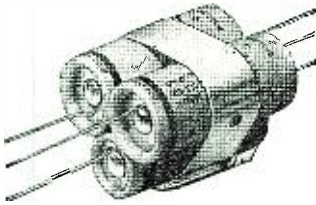

Ask for Sprague Atoms (midge dries) by name! Use them universally on EVERY electrolytic condenser replacement job!

**TUBES WANTED**—Will pay list price for new 50L6, 35Z5, 35L6, 12SA7 and numerous others. Have an over-supply of various other tubes for sale or exchange. Send 3c stamp for list. Dolan Radio Service, 187 Union St., Randolph, Mass.

**RIDER'S MANUALS WANTED**—Vols. 9, 10, and 11. Will pay cash. Also want an 0-1 Ma-meter in good condition. Jim's Radio Shop, Mankato, Kans.

**WILL SWAP OR SELL**—Seeburg automatic record changer, 12 record cap., good cond. with pick-up pro. model, commercial type multiple selection, \$35; also Readrite analyzer model No. 710-A, will take octal tubes, minus 0-10 ac voltmeter, measures dc v. & ma., 2 mtrs. inc., working cond., can be used as multi-mtr., sold new for \$35, only \$10. Askin Radio Service, 1107 S. Main St., Paris, Ill.

**WANTED**—A 32 v. D.C. to 110 v. A.C. converter or vibrapack, 75-150 watt, in good condition. Henry Bouw, Pepacton, N. Y.

**FOR SALE**—134 issues of SERVICE (radio magazine) from March 1932 to May, 1942, for \$25. All in good condition. A. Abrahamson, 2633 Johnson St., N. E., Minneapolis, Minn.

**WANTED**—30 juke box or phono amplifiers, new or used; 2A3 or 6L6 outputs; also Racor or University trumpets, units and horns. Cash. Engineering Associates, 410 Marian Avenue, Lima, Ohio.

**FOR SALE**—Rola G12—2500 field, 18-watts, \$4; 2 aluminum bells and enclosure for 10 in. speaker, \$3.50 each; 40 Meissner 1F transformer 465KC, \$10; one Atlas WX8 reflexed enclosure (like new) \$10. Francis Higgins, 14965 Bringard, Detroit, Mich.

**WANTED**—Thordarson 2A3 phono amplifier, or these Thordarson parts: T-15R05 power transformer, T-90A04 audio trans., T-90S13 output trans., T-15C54 choke, T-74C30 choke, T-67C46 choke, T-18C92 choke, T-14C70 choke. Cash or trade. Send for list. John Repa, Jr., Richlandtown, Pa.

**FOR SALE**—Supreme model 385 in A-1 condition; also Radio City CO tube checker model 303A, complete with test leads and instructions. Walter Grigaites, R-2, Granville, Ill.

**WILL BUY FOR CASH**—A V.O.M. of reputable make in excellent condition. Would prefer Hickok or Precision, 25,000 ohms per volt. Do not want a V. T.V.M. Write giving model number, full details of ranges, and price. Cook's Radio Lab., 1110 Prince St., Brunswick, Ga.

**FOR SALE**—Supreme tube tester type 145, used only a short time, in A-1 condition, in original carton, with instruction sheet. Refer to Rider's Manuals for hook-up and description. Will ship by C.O.D. mail or express for \$25—\$5 deposit, bal. \$20 on delivery. Truitt Radio Service, Novinger, Mo.

**IN THE MARKET**—For Ohmmeter, signal generator and tube checker. What have you? Send description and price. A. Fischer, 1529 White Plains Road, New York 60, N. Y.

**WANTED AT ONCE**—Tube-tester, oscillator and analyzer, or V.O.M., for testing latest sets. Give full description and price. Thompson Radio Service, 1700 River Rd., Port Blanchard, Pittston, Pa.

**RECORDER WANTED**—Professional or semi-professional, portable model. Would accept quality radio-recorder combination. What have you? Wm. V. Drinkard, General Delivery, Manette Sta., Bremerton, Wash.

**COMMUNICATION RECEIVER**

**WANTED**—Such as HQ-120-X in good condition with speaker. Give full details and price. Sgt. Alex O'Kulich, Co. A 2nd Arm'd Sig. Bn., East Garrison, Fort Ord, Calif.

**FOR SALE**—Two type B5 Bliley Xtals, new sealed holders, frequencies 7212 and 7224, never used. WANT National One Ten receiver, R.M.E. Dm30XA or DM36A Browning converter; Abbott TR 4 MRT 3 or a S 29 Sky Traveller. V. Howerdel, 102 Hancock Ave., Jersey City, N. J.

## Your own ad run FREE!

The "Trading Post" is Sprague's way of helping radio servicemen obtain the parts and equipment they need, or dispose of the things they do not need during this period of wartime shortages. Send in your own ad today—to appear free of charge in this or one of the several other leading radio magazines on our list. Keep it short—WRITE CLEARLY—and confine it to radio items. "Emergency" ads will receive first attention. Address it to:

SPRAGUE PRODUCTS CO., Dept. RN38  
North Adams, Mass.

**WANTED**—Volt-ohm-mil. meter; signal generator, also Rider's Manuals. State price in first letter and give full description. Wm. J. Schwallier, 514 Ninth St., Henderson, Ky.

**FOR SALE**—35-watt amplifier, 12-in. P.M. speakers and carrying case; Racor giant units. National Sound Equipment Co., 625 Main St., Worcester, Mass.

**WILL PAY CASH**—For Hickok 155 Tracometer or Rider chanalyst; also want appliance tester such as Hickok model 900. Must be in A-1 condition. Clyde Smith, Samson Radio Shop, Samson, Ala.

**FOR QUICK CASH SALE**

Complete radio servicing laboratory, as follows: Complete set of Rider's Manuals, Vols. 1 to 11; up-to-date Supreme instruments, oscilloscope, analyzer, signal generator and frequency modulator, audolyzer, tube and set tester; Triplett signal generator and multimeter; Crosley manuals; Mallory-Yaxley Encyclopedias; eight-drawer metal parts cabinet; strong chassis cradle; workbench; 275 resistors; 40 jars filled with nuts, screws, washers, lugs; 30 condensers; complete set high-speed drills; drill gauge, wire gauge, screw gauge; dozens of drills, taps, dies, etc.; 100 vacuum tubes, all good; hundreds of small parts too numerous to mention; Philco manual; tube manuals; 250 radio magazines. Leaving for service. Will close out for \$400 for immediate cash sale. Edwin A. Seeburg, 143 Washington St., Long Branch, N.J.

**WANTED**—British Admiralty Handbook of Wireless Telegraphy, Vols. I and II, in good condition. Will pay cash. G. A. Soderlund, Box No. 40, Sturgis, Sask., Canada.

**FOR SALE**—Readrite No. 710-A set tester, three meters — D.C. voltmeter, A.C. voltmeter, D.C. milliamperes—price \$20. Set includes accessories and instruction sheet, and has been used only 3 times. Jacob Husak, Center Moriches, N. Y.

**WANTED**—B.R. 151 Jensen speaker cabinet (for 1.5-in. speaker) new or used. Give full particulars and price. Robert E. Woolf, 406 E. University, Gainesville, Fla.

**FOR SALE**—Stancor model 125 6-volt power pack; Janette CH25, 75 watt, 115DC-110AC converter; Green Flyer automatic, 2 speed record player; 8-in. Jensen peri-dynamic speaker and case; tubes; resistors; and condensers. Kenneth Stoll, 512 5th Ave., Asbury Park, N. J.

**FOR SALE OR SWAP**—Hickok AC49 tube tester mutual conductance type up to 30 volt; adaptors for some metal tubes, \$15; P.P. parallel 50's amplifier Western Electric parts, \$30; Peerless speaker, \$2; 2 MF paper condensers 200 v. 15c; woodlathe, \$12. Want gas generator. Al. R. Dayes, 1418 81st St., Brooklyn, N. Y.

**FOR SALE**—One GE No. AZ-133A phonograph motor complete with turntable; one Motorola 8-tube push button auto radio No. 969; one Jewel pattern No. 54 0-3 DC ammeter; one Jewel pattern No. 54 0-7 and 0-140 combination DC voltmeter. Write for prices and details. Louis E. Farrell, 316 Pine St., Burlington, Vt.

## THEIR LITTLE ADS BROUGHT BIG RESULTS!

### A Few Typical Comments From Among Hundreds We Have Received

"I have had excellent requests from my Trading Post ad—seven requests in three days, and they're still coming." W. T. N., Illinois.

"Thank you for my advertisement in the Sprague Trading Post. Received 4 replies to my request for an oscilloscope." G. B., Brooklyn.

"I made a trade on a Rider Manual for the micrometer. Thank you again." C. D. L., New Jersey.

"Thanks for running my ad—I sold two meters right off the bat." A. R. D., New York.

"I received an answer to my ad two days after the magazine came out, and a week later I had the oscillator I wanted." F. L., Conn.

"Received several replies and purchased the condenser tester I needed. I gave the other replies to other servicemen who also needed such equipment." J. A. S., New York.

"Please accept my sincere thanks. I was literally swamped with replies to my Sprague Trading Post ad and had no difficulty in disposing of the apparatus at a good price. This is a splendid service you are rendering—and just one more reason why we servicemen will continue to buy Sprague Condensers." R. B., New York.

**Send in Your Ad TODAY!**



SPRAGUE  
PRODUCTS CO.  
North Adams, Mass.

# SPRAGUE CONDENSERS AND KOOLOHM RESISTORS

Obviously, Sprague cannot assume any responsibility, or guarantee goods, services, etc. which might be exchanged through the above advertisements.

Porter possesses a keen knowledge of radio communications and equipment that is being used so successfully by our troops. He is well known in Washington and contributed greatly in the preparation of the November, 1942 Special U. S. Army Signal Corps issue of RADIO NEWS. Our readers will be given exclusive material and photos direct from our various fighting fronts. American manufacturers of radio equipment will welcome this addition to our staff as Mr. Porter will be able to get first hand information as to the performance of their units in combat. We know that our readers join us in wishing Mr. Porter bon voyage and a happy return.

**MAJOR GENERAL DAWSON OLMSTEAD**, formerly Chief Signal Officer of the United States Army, retired on June 30 to take over his new position as Military Representative on the Telecommunication Board. The new Chief Signal Officer is Major General Harry E. Ingles of Lincoln, Nebraska, formerly Deputy Commander of American troops in the European theater under the late Lt. General Frank M. Andrews. The editors of RADIO NEWS are proud to have been able to present the story on the part that the SCR-299 (developed as a result of Gen. Olmstead's original idea for a fast-moving mobile radio unit) has played in maintaining our communications on our many fighting fronts, particularly during the recent African campaign. This story was

based on a recent interview with General Olmstead whom we have had the pleasure of knowing personally for many months. We know that our readers join with us in extending our congratulations to General Olmstead, and to General Ingles, our new Chief Signal Officer. 73 . . . OR

**Scientific Farming**  
(Continued from page 31)

These experiments have advanced sufficiently to give validity to the idea that improvement of strains of fruits and vegetables is possible through the use of electrons.

Soil scientists of the U.S. Dept. of Agriculture have determined by pioneering experiments that radio waves have great value in adding extra fertility to some soils. The Westinghouse Electric & Manufacturing Company has designed an electronic eye for measuring the radiation of the sun in different sections of the country. These radionic devices resemble an oversized radio tube. At its upper end is a flat metal button about the size of a fifty-cent piece, surrounded by a circular wire electrode. As a sun meter, the metal button in its refined state is sensitive only to that portion of the ultraviolet light in sunlight which produces sunburn. Sun rays, hitting the surface of the disc, cause the metal to release a stream of photo electrons which pass to the electrode. So small is the current passed that it must be expressed

in micro-watts. These electrons, by means of proper circuits, cause a small condenser to charge up. After a period of several seconds the condenser discharges, actuating a sensitive relay trigger. These discharges can be very accurately counted by means of a recording device and are then used by the scientist and the agricultural colleges in making crop studies and surveys for the benefit of the farmer.

Perhaps one of the most startling accomplishments credited to radionics, which will result in greatly increased production, is the discovery of the exact nature of the tobacco mosaic virus. By means of the radionic microscope scientists have been able to see, for the first time, this virus of the plant disease which for many years has cost tobacco growers untold millions of dollars. While it is too early to announce any definite results from this discovery in the way of a cure, the future holds promise of complete success. This microscope will be used more and more in the discovery and cure of other plant diseases.

Pasteurization is the process of exposing liquids to a temperature of 131 to 158 degrees Fahrenheit for a definite period of time in order to kill all bacteria which cause fermentation. However, this process, in the light of present day knowledge, leaves much to be desired since this high temperature destroys some of the vitamins present. A new process of sterilization without the use of heat or chemicals has been announced by the inventor, Herbert S. Ogden, of Los Angeles, California. This process uses electron streams to accomplish the desired result. The use of this process does not exercise a contaminating influence by the presence of ozone or other chemical odors. It affords an agent having uniform action, literally bombarding the milk or other fluid with millions of electrons. The flow of liquid through the system is at a predetermined rate, this being determined by the density of the fluid, the intensity of the sterilizing agent, and the minimum number of bacteria to be tolerated. More simply, the process consists of forming a film of milk or other liquid on a moving surface and then directing a stream of ultra violet rays through this film for a specified length of time. The time element is governed by such factors as the number of bacteria to be destroyed, the intensity of the electronic ray and the density of the liquid.

The apparatus has a supporting frame which somewhat resembles an automobile motor hood. Contained within the supporting framework is a gas-tight, enclosed hood, sealed against a section of the main support by sealing material and a wing nut. Resting on this section, or member, is a ball-bearing, which is a journaled shaft of a closed cylinder.

A portable outfit could be made for dehydrating soybean, fodder, alfalfa, clover, and grass. More nutritious hay, with greater carotene and vitamin content is promised by such a machine,

GONE ARE THE DOODABS!  
TODAY THE ACCENTS ON

**RUGGED CONSTRUCTION**  
of

- CABINETS
- CHASSIS
- PANELS
- RACKS

for ELECTRONIC APPARATUS

Send specifications, or write for our Catalog No. 41A.



**PAR-METAL PRODUCTS CORPORATION**  
32-62—49th STREET . . . LONG ISLAND CITY, N. Y.  
Export Dept. 100 Varick St., N. Y. C.

# "Position X evacuated!" TRAINED MEN advance now!"



(Draft Age Men: TRAIN Before Entering Service)

GET READY FOR YOUR OPPORTUNITY . . . It's HERE! Radio technicians are needed everywhere; afield in action, and at home in industry! Trained men are needed in the Army, Navy and Air and Signal Corps, Government Defense Service and Civilian fields. Now, in answer to repeated demands for Trained Radio Technicians, National Schools has extended its famous Shop Methods so you can qualify right at home. You can quickly prepare to be of greatest service to your Country and yourself. Yes, right at home, in your spare time. National's time-tested plan of Home Training will definitely establish you, in a short time, so you can hold a good job in this fascinating field. Furthermore, you become equipped for an even bigger career in the years of reconstruction after the war. Learn Radio in all its practical branches by National's proven methods.

## Get into RADIO now

### QUALIFY FOR THESE TOP PAY JOBS

Radio Expert  
Broadcasting

Aircraft—Marine

Indust. Electronics

Studio Technician

U. S. Govt. Service

Re-Manufacture

#### NATIONAL GRADUATES WIN GOOD POSITIONS

Thousands of graduates of National Schools are employed throughout America and in many parts of the World—strong testimonials of successful Training.



"National Schools has done wonderful work for the man who wants to get ahead in life. Your trained man can get a job at a much higher salary."

O. K. Ivey  
Washington, D. C.



"Your schooling helped me obtain a swell job now, in the Navy. I am following the profession I learned at National. It will help my chances for rapid advancement."

E. Schroeder  
U. S. Navy

### FREE Trial Lesson & Opportunity Book

You'll be amazed when you receive our Free Trial Lesson, Opportunity Book and full details. No obligation: no cost. Investigate.



#### MEN SUBJECT TO MILITARY SERVICE AIDED BY TRAINING

Many men in military Service have enrolled. This self-improvement means rapid advancement now and high pay after the war.

2  
BOOKS  
FREE



### TESTED HOME TRAINING BY PROVED SHOP-FIELD METHOD

Unlike any other course of Home Training, National Schools brings you a personalized, instructor-to-student series of assignments—an actual extension of the same study and training you would receive if you attended the School in person. National's Victory Training Plan speeds up your radio progress right from the start, yet omits absolutely nothing vital to your preparation for entering Radio in any of its branches. Squarely behind your Home Training are the modern, completely-equipped training shops of National Schools where we develop and prove every shop method assignment sent to you. Every phase of your training is personally supervised by an established faculty of practical, experienced instructors and engineers who have the knack of imparting knowledge, ways and means of guiding you, so that with each succeeding lesson you become more and more enthusiastic.

#### FASCINATING WAY TO LEARN RADIO

You learn by the most practical shop-laboratory methods—using the same instructions and technique as employed in radio shops, studios, production plants and U. S. Govt. services. Your training assignments grow more fascinating as you progress, step by step, through fundamentals of radio, construction, layouts, operating routine, etc. Amazing as it may seem, you acquire this useful workable training AT HOME. Quality for good pay job with assured success not only in war-time but later after the war ends when Radio will continue its vast expansion.

#### GET INTO THIS BOOM INDUSTRY NOW

The Radio industry is part of the Electronics group of over 10,000 establishments which design, manufacture, purchase and sell a BILLION dollars' worth of equipment annually. National instructors keep abreast of all these developments in order to prepare you *today* for the future. It's a BIG FIELD and it's smart to plan NOW to train yourself to reap the rewards that will come after the war to the National Schools' Trained Radio Technician. A penny postal on the coupon below brings you free, complete information that may change your entire life's work. Mail it right away.



## NATIONAL SCHOOLS

Los Angeles  
California

ESTABLISHED  
1905



### MAIL OPPORTUNITY COUPON FOR QUICK ACTION

National Schools, Dept. RN-8 (Mail in envelope or  
4000 So. Figueroa, Los Angeles, Calif. paste on penny postal)

Mail me FREE, without obligation, one Lesson and Opportunity Book, with full details about how I CAN become a RADIO Technician.

NAME \_\_\_\_\_ AGE \_\_\_\_\_

ADDRESS \_\_\_\_\_

CITY \_\_\_\_\_ STATE \_\_\_\_\_

— THE START TO SUCCESS COUPON —

## Will YOU



### Be "Let Out" ... When The "Let Down" Comes?

#### PREPARE NOW FOR THAT PERMANENT RADIO JOB!

After the war . . . what? Will you be lucky enough to carry on in your present job? Probably not! When the "let down" comes, sudden changes will take place as America goes back to peacetime production, and millions of men come back from the Armed Forces to take up their old jobs.

**Don't be caught unprepared!** To put it frankly, the job you hold today is temporary at least. The important, career jobs that provide you with a secure future . . . the positions with the good-paying salaries, still belong to the technically qualified men, and must be won and held on ABILITY!

Now is the time to look into the future . . . to make sure of the road ahead. Now is the time to devote your spare hours in creating a secure future for yourself and family. Now is the time to invest a small portion of your present earnings in a proven program for advancement.

**CREI home-study courses** in Practical Radio Engineering have been studied by more than 8,000 professional radiomen. Today, hundreds of ambitious men, just like yourself, are taking our specialized spare-time training to give them the technical skill to supplement their present ability . . . to earn a better living . . . and to create a secure place for themselves in the great postwar world of radio and electronics.

**Don't say YOU haven't the time.** CREI courses are designed to be studied in the most crowded schedules. You can study a few hours a week without interfering with your present work. In the years to come, you will "cash in" on your increased knowledge and ability gained from spare-time study. So, write for all the facts now—for this is the time to make sure that your preparation for postwar success shall not be "too little, too late"!

#### • WRITE FOR FREE 32-PAGE BOOKLET

If you have had professional or amateur radio experience and want to make more money—let us prove to you we have something you need to qualify for a better radio job. **To help us intelligently answer your inquiry, PLEASE STATE BRIEFLY YOUR BACKGROUND OF EXPERIENCE, EDUCATION AND PRESENT POSITION.**



## CAPITOL RADIO ENGINEERING INSTITUTE

E. H. RIETZKE, President

Home Study Courses in Practical Radio  
Engineering for Professional Self-Improvement

Dept. RN-8, 3224—16th Street, N. W.  
WASHINGTON, 10, D. C.

Contractors to the U. S. Signal Corps—U. S. Navy,  
U. S. Coast Guard, Producers of Well-trained Technical  
Radiomen for Industry.

which separates the leafy portions from the woody stem and crushes the sappy parts, the electric eye being the expert grader. This dehydrator would combine several functions into one operation. It would feed green fodder or other material intended for livestock onto an endless belt, cut the plants into suitable lengths, separate, electronically, the leafy portions from the sappy stems, crush the stalks, pick up the layer of drying material, turn it upside down and deposit it loosely along the traveling conveyor. Soybeans, alfalfa or clover are loaded onto this slowly moving conveyor belt. After passing through crushing rollers which pulverize the sappy stems to a more rapidly drying status, they are then carried through a heating chamber where moisture is expelled. During the process of drying, the temperature is adjusted correctly, thus avoiding scorching or burning the material, a common complaint with some driers. There are a succession of heat zones each supplied with low humidity air, heated to exactly the right temperature, to attain the maximum evaporative effect for each stage of the dehydrating process. The drying is conducted, in part, in an oxygen-free atmosphere and in a chamber wherein all products of combustion are burned completely without smoke.

The units of this community dehydrator consist of a supporting framework; a continuous belt of two flexible steel bands mounted on the framework; a main boxlike structure, extending the length of the conveyor belt and forming an airtight housing for the conveyor screen; another chamber which has a metallic tube and an oil burner for heating the material to be dehydrated; electronic tubes; and other equipment. The interior of the drying chamber has eight cross openings with an air intake opening controlled by a door. This series of hot-air discharge chambers provides an accurate control over the amount of hot gas admitted to chambers.

The above mentioned examples of various applications of radionics to modern farming, serve to show to a certain extent what progress has been made and something of what may be expected in the future. No article of this nature would be complete without mentioning the future possibilities of maintenance and repair in this field. The many radionic devices, which are now available, and those which will be available in the future, will require the services of a great many trained technicians. Men presently engaged in radio servicing, or kindred maintenance, will find this a profitable and timely field to enter. The servicing of the devices should do much to build a splendid post war business for these men, particularly in rural areas.

It is important that the serviceman bring his knowledge up to date on these new devices in order that he can take full advantage of these new opportunities.

## Saga of Vacuum Tube

(Continued from page 27)

the tube, and hence might not be considered to be within the scope of the de Forest patents. On December 31, 1918, U.S. Patent No. 1,289,981 was issued to Weagant on a tube of this type.<sup>117</sup> (See Figure 30.) The Weagant Valve, as the device was called, was never applied commercially to any great extent, probably because the decision in the Marconi-de Forest suit was favorable to the Marconi Company. Figures 31, 32, and 33 show various forms of the Weagant Valve, that of Figure 33 being a proposed commercial form of the device. The circuits to be used with this valve were similar to those used with the conventional three-electrode tube, and were published in a magazine article about the time the patent was issued.<sup>118</sup>

With the development of the multi-electrode tubes of the late 1920s and early 1930s communications engineers had available a method of obtaining substantial amplifications at radio fre-

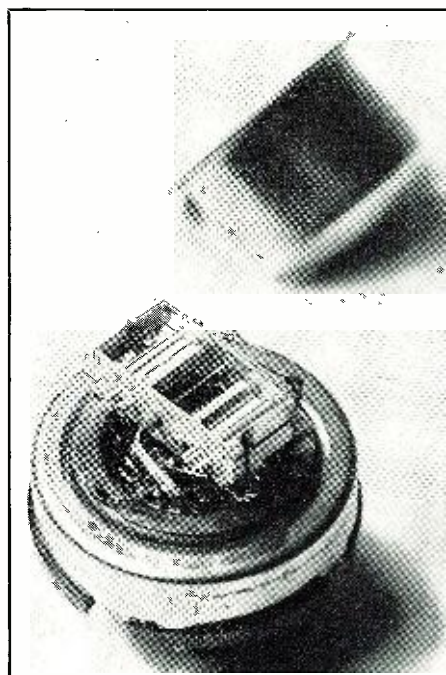

Figure 34.

quencies. This resulted in a second revival of the diode for use as a detector. When the signal input to the detector can be made of the proper value, this type of detection presents certain advantages in the way of freedom from distortion. Hence many modern radio receivers use such detectors. A typical detector tube of this sort is the RCA 6H6, which is a double diode detector. Study of Figure 34 will clearly show the changes which differentiate this modern diode from its progenitor, the Fleming valve. These advances are in the nature of engineering refinements, the principle of operation is still the same. The output, however, is utilized not only



**"IT'S A SWELL PLACE FOR MY  
ECHOPHONE EC-1 AND BESIDES,  
SHE LIKES TO GET POLICE CALLS"**



**Echophone Model EC-1** 6 tubes, 3 bands. Tunes from 550 kc. to 30 mc. Beat frequency oscillator. Bandsread logging scale. Self-contained speaker. Electrical bandsread on all bands AC/DC. 115-125 volts ECHOPHONE RADIO CO., 201 EAST 26TH ST., CHICAGO, ILLINOIS

to provide the audio waveform which was superimposed on the carrier at the transmitter, but also to provide energy for other purposes, such as automatic adjustment of the gain of the preceding radio frequency amplifier. This provides an audio frequency output which is reasonably constant and independent of the variations in the received signal over the operating range of the circuit.

There is still another use of the diode on which we have not yet touched. This is in the field of power frequency rectification. In the early wireless receivers, even well into the broadcast era, dry cells or small storage batteries were used as a source

of plate potential. Their use had its disadvantages. The cost was high for the energy which they furnished. The plate potential always existed, even though the set was not in operation, and might be dangerous. If heavy duty batteries were used, in an attempt to reduce the cost per energy unit, the space required for them might be as great as for all the rest of the receiving equipment. These disadvantages became more important with the trend to the higher voltages required for the power output tubes needed for satisfactory loud-speaker operation.

In the case of tube transmitters, the plate potential was at first supplied

by generators. High voltage d.c. generators are difficult and expensive to build and, like all rotating machinery, require expert maintenance. A static source of power for the transmitting tubes was much to be preferred, hence the power rectifier was developed.

The first power frequency rectifier of the thermionic type was due to Dr. Arthur Wehnelt of the University of Erlangen, the inventor of the Wehnelt, or oxide-coated, cathode.

In 1903 Wehnelt published a paper<sup>119</sup> describing a method of obtaining "negative ions" in great quantities from incandescent metallic compounds. He used a platinum wire, or platinum strip, coated with calcium or barium oxide, as the cathode in a discharge tube and found that there was a strong emission of negative ions from the

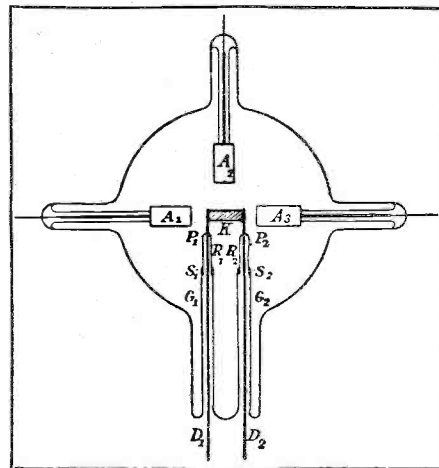

Fig. 35.

cathode when it was made incandescent. He further described experiments which he made on these phenomena in other papers in 1903<sup>120</sup> and 1904.<sup>121</sup>

On January 15, 1904, he applied for a German patent<sup>122</sup> for the use of such a discharge tube, containing a heated cathode with these metallic oxides, as a rectifier for transforming single phase and polyphase alternating currents into direct currents. No mention was made of any application to high frequency oscillations or wireless telegraph use.

In 1905 he described the use of this device in an article<sup>123</sup> entitled "An Electric Valve Tube" and suggested its use for charging storage batteries, and for supplying potential for the direct operation of Roentgen tubes. This paper was a short summary and was followed by a more complete exposition in 1906.<sup>124</sup> In this last paper he showed that this valve-tube could also be used as a rectifier of high frequency currents. However, it should be noted that this was subsequent to the papers published by Fleming on the use of his valve as a rectifier of high frequency oscillations, and in fact Wehnelt refers to Fleming's work in a footnote in his article. The tube as constructed by Wehnelt is shown in Figure 35.

There appears to have been little

# 9 out of 10

## BUSY RADIO TECHNICIANS SAID

"HERE'S THE WAY TO LEARN RADIO RIGHT!"

**724 OUT OF 817!** When you want the facts about something—go to the men who know! When you want to know what is the best Radio Training for YOU—ask Radio men! That was exactly our idea when we went to a mixed group of 817 radio men, including radio instructors and students, repair men, radio men in the armed forces and in big manufacturing plants, and asked them exactly what they think of various books and courses for the study of Radio and Electronic fundamentals. NINE OUT OF TEN of these men wrote back that Ghirardi's RADIO PHYSICS COURSE book is their choice as the best buy on the market—far better than any other book or course they have ever seen!

### HERE ARE THE REASONS WHY:

1. "Its simple, clear way of explaining every detail makes it the most easily understood of all Radio books"
2. "Teaches Radio fundamentals more quickly and interestingly than any other"
3. "Gives the most complete coverage of Radio and Electronic subjects"
4. "Is the most inexpensive complete Radio training available. Easily worth \$50 to \$100 if bought as a course"

RADIO PHYSICS COURSE is a big, 972-page book—larger than any other of its type. Actually, it gives you the scope of 36 courses in one—for only \$5 complete—combined into nearly 1000 pages, with more than 500 special illustrations, and containing 856 self-testing review questions.

### ELECTRONICS, TOO!

And don't forget—the basic instruction in this big book is your introduction to the vast, rapidly expanding field of Electronics—your "Open Sesame!" to this amazing new industry you've been reading so much about!

Mail the coupon today—without assuming any risk. Get started now for a well-paying Radio-Electronics future!

Radio & Technical Publishing Co.  
Dept. RN 83, 45 Astor Place, New York 3, N. Y.

Rush me a copy of your big 972-page RADIO PHYSICS COURSE book, \$5 enclosed (\$5.50 foreign).

Send C. O. D. for \$5 (\$5.50 foreign) plus postage.

In either case, I may return the book within 5 days for refund.

Name.....

Address.....

City..... State.....

**COMPLETE BASIC RADIO TRAINING in one big volume!**

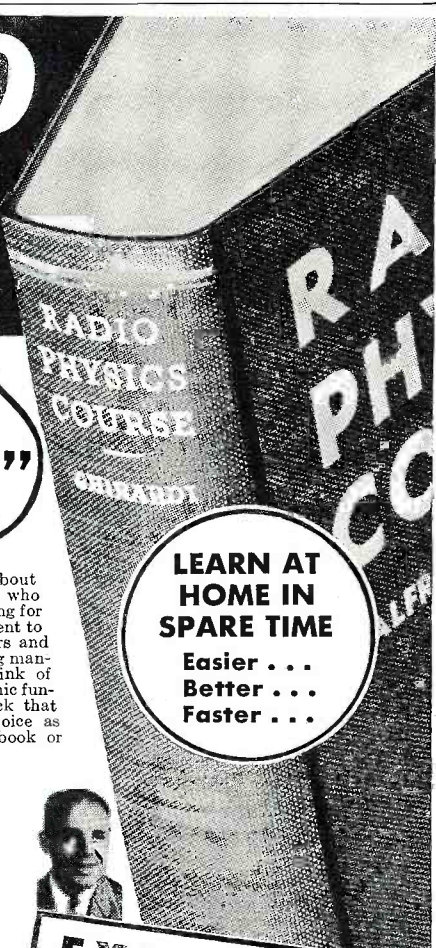

**EXAMINE IT FOR 5 DAYS!**  
**You be the Judge!**

We don't ask you to take any risk. We only ask an opportunity to PROVE what Ghirardi's RADIO PHYSICS COURSE book can do for you. Send for it today! Our 5-day Money-Back Trial Offer is your absolute protection.

**ONLY \$5 COMPLETE**

# DO YOU KNOW THE **UTAH** PARTS USED IN THESE PRODUCTS? (ANSWERS AT BOTTOM OF PAGE)

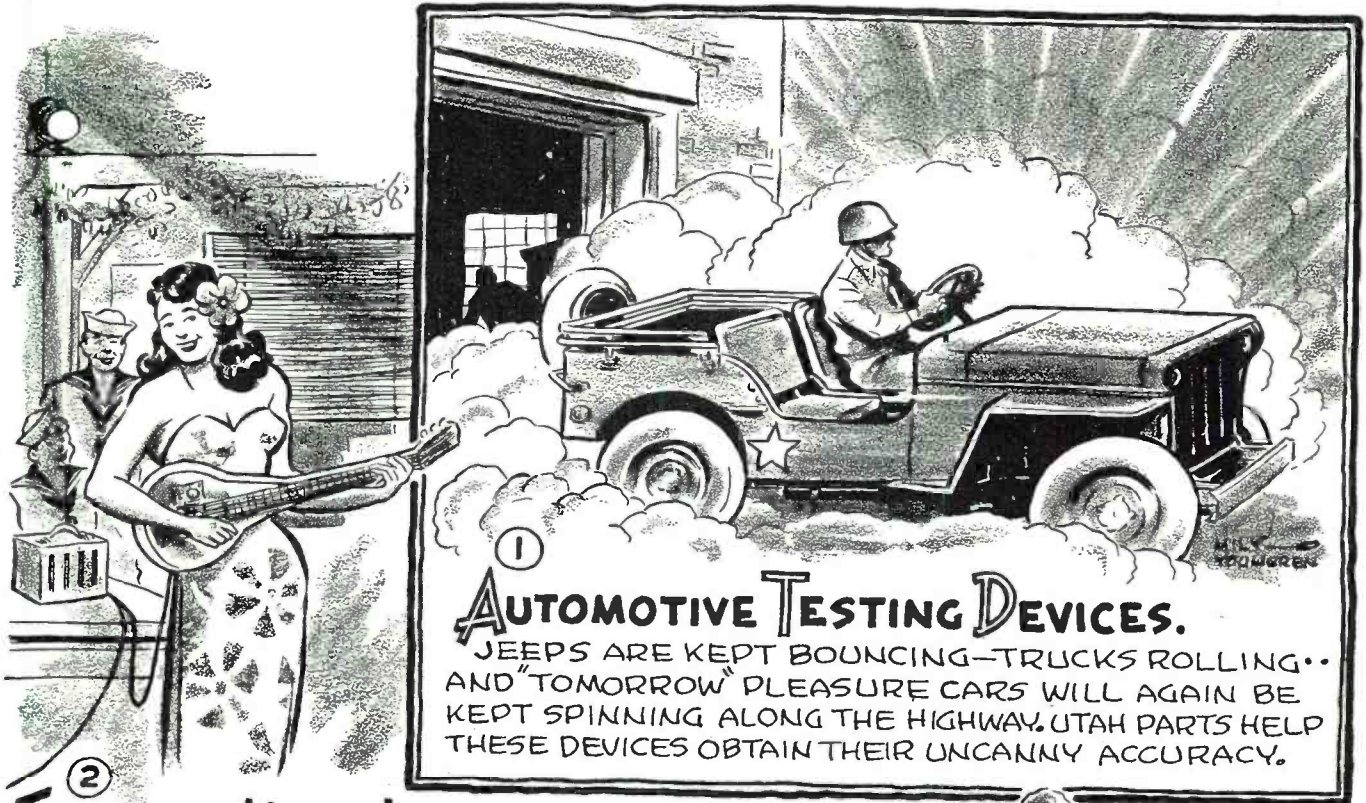

## ① **AUTOMOTIVE TESTING DEVICES.**

JEeps ARE KEPT BOUNCING—TRUCKS ROLLING— AND "TOMORROW" PLEASURE CARS WILL AGAIN BE KEPT SPINNING ALONG THE HIGHWAY. UTAH PARTS HELP THESE DEVICES OBTAIN THEIR UNCANNY ACCURACY.

② **ELECTRIC MUSIC INSTRUMENTS.** SOFT LIGHTS AND SWEET MUSIC—AND IT'S RELAXATION FOR SERVICEMEN IN THEIR OFF-DUTY HOURS. UTAH PARTS AMPLIFY THE TONES, AS THEY COME FORTH GOLDEN AND VIBRANT

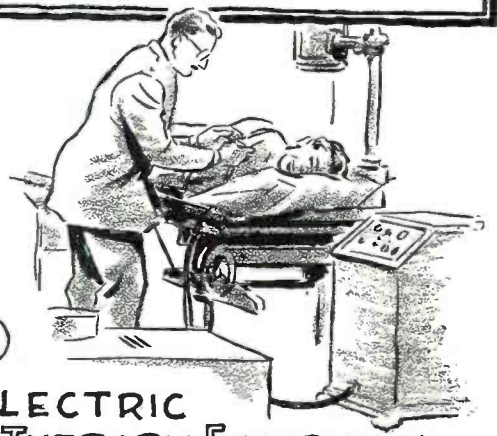

## ③ **ELECTRIC THERAPY EQUIPMENT**

LENDs ITS MAGIC HEALING POWERS TO SOLDIER AND CIVILIAN ALIKE. IN THIS APPARATUS WILL BE FOUND PARTS BY UTAH...ASSURING MAXIMUM DEPENDABILITY AND LONG LIFE.

**THESE** COMPRISE BUT A SMALL CROSS-SECTION OF THE VAST NUMBERS OF PRODUCTS EMPLOYING UTAH PARTS. IT MAY BE THAT YOUR ELECTRICAL PROBLEM, TOO, CAN BE SOLVED WITH A PRECISION-MADE UTAH PART. REMEMBER THAT UTAH ENGINEERS HAVE HAD WIDE EXPERIENCE IN SOLVING WARTIME ELECTRICAL PROBLEMS...AND THERE IS A COMPLETE LINE OF UTAH PRODUCTS AVAILABLE, INCLUDING WIREWOUND CONTROLS, JACKS, RESISTORS, SWITCHES, TRANSFORMERS, SPEAKERS, ETC. WRITE TODAY FOR ALL THE FACTS.



UTAH RADIO PRODUCTS COMPANY, 824 Orleans Street, Chicago, Illinois • Canadian Office: 560 King Street, West, Toronto  
 In Argentine: UCOA RADIO PRODUCTS CO., S. R. L., Buenos Aires • Cable Address: UTARADIO, Chicago

Power Resistors, Switches, Potentiometers, Phone Plugs & Jacks, Potentiometers, Switches, Resistors, Switches, Potentiometers

**PERFECTION**  
from a  
**HUNDRED PAIRS**  
**OF HANDS**

The "human element" so consistently mentioned as a necessary part of every great accomplishment, is exemplified in the high quality of Thordarson transformers. From engineering laboratory to final inspection, countless pairs of hands and minds work in harmony to bring about in each complete transformer a coordination of effort that makes for superb performance.

**THORDARSON**  
ELECTRIC MFG. COMPANY  
500 WEST HURON ST., CHICAGO, ILL.  
*Transformer Specialists Since 1895*  
ORIGINATORS OF TRU-FIDELITY AMPLIFIERS

Only a few copies left of the

Special U. S. Aviation Communications  
Issue of RADIO NEWS, June, 1943

*Better Get Yours Now!*

**ONAN**  
ELECTRIC PLANTS

*Electricity for Any Job Anywhere*

ONAN GASOLINE DRIVEN ELECTRIC PLANTS provide electricity in locations where it is not otherwise available, and for emergency and standby service for all communications work.

Thousands of these reliable, sturdy Plants are doing a winning job on all the fighting fronts by providing electricity for communication and other vital war tasks. Ratings from 350 to 35,000 watts. A.C. 50 to 800 cycles, 110 to 660 volts. D.C. 6 to 4000 volts. Also dual A.C. and D.C. output models. Air or water cooled.

Details gladly furnished on your present or post-war need for Electric Plants.

**D. W. ONAN & SONS**  
1881 Royalston Ave., Minneapolis, Minn.

done in this phase of diode development for a number of years thereafter, until the necessity arose for obtaining very high direct current potentials for x-ray work. The initiative in the subsequent development work along this line appears to have been taken by the General Electric Company, whose work will be described in a subsequent article.

### References

113. Willows, Dr. R. S. and Hill, S. E.: "Vacuum Oscillation Detectors." *Electrician*, Vol. 48, No. 8, December 1, 1911, pp. 302-303.
114. Dietzen Vacuum Tube: See advertisement in *Radio News*, Vol. 5, No. 5, November 1923, p. 659.
115. Electrad Diode: See advertisement in *Popular Radio*, May 1923, p. 22.
116. Margo Detector: See advertisement in *Radio News*, Vol. 5, No. 2, August 1923, p. 206.
117. Weagant, Roy A.: U. S. Patent No. 1,289,981, application date April 2, 1915, issued December 31, 1918.
118. The Weagant Oscillation Valve: A striking improvement on the original Fleming oscillation valve. *Wireless Age*, March 1919, pp. 24-25.
119. Wehnelt, Arthur: *Sitzungsberichte der Physikalische-Medecin Societat zu Erlangen*, 1903, pp. 150-158.
120. Wehnelt, Arthur: *Verhandlungen der Deutsche Physikalische Gesellschaft*, Vol. 5, 1903, pp. 150-158 and 423-426.
121. Wehnelt, Arthur: "Über den Austritt negativer Ionen aus glühenden Metallverbindungen und damit zusammen hangende Erscheinungen." *Annalen der Physik*, Vol. 14, 1904, pp. 425-468. See also *Physikalische Zeitschrift*, Vol. 5, No. 31, 1904.
122. Wehnelt, Arthur: German Patent No. 157,845, Klasse 21g, application filed January 15, 1904, issued January 13, 1905.
123. Wehnelt, Arthur: *Sitzungsber. der Physik-Medic. Soc. zu Erlangen*, Vol. 37, 1905, pp. 264-269. This is an abstract of the paper referred to in reference 124.
124. Wehnelt, Arthur: "Ein Electricische Ventilrohr." *Annalen der Physik*, Vol. 19, 1906, pp. 138-156.

### Figure Captions

Figure 28. Fleming's Later United States Patent, showing use of biasing potential on plate.

Figure 29. Left and Center, Electrad Diode. Right--Margo Detector.

Figure 30. Weagant Valve Patent.

Figure 31. Left--Weagant Valve with outside electrostatic control element in position. Right--Weagant Valve with control element removed. Photograph Courtesy *Radio Corporation of America*.

Figure 32. Group of experimental Weagant Valves.

Figure 33. Proposed Commercial Form of Weagant Valve.

Figure 34. Modern Diode. RCA 6H6 with cover removed. Photograph Courtesy *Radio Corporation of America*.

Figure 35. Wehnelt Rectifier for Three Phase Operation. Reproduced from *Annalen der Physik*—1906.

# The Need for Civilian Radio Service Men is Great...

## Will You Help?



**E**nlistments and drafting of radio service engineers has cut deeply into the ranks of the service men whose job on the home front is to "keep 'em listening."

In some communities, home set servicing is seriously crippled because of lack of service skill. The need for developing new radio service engineering skill is acute. Yet there are thousands of "old timers"—old "radio bugs" if you please—as well as youngsters who have a technical turn of mind, who will be eager to help—if told of the existing need.

Here is a patriotic chance for those of you who remain on the home front. You have the facilities, the know-how, the sources of information to organize radio servicing classes, secure competent instruction and provide the knowledge that will enable set owners to receive help.

You have a big opportunity to help "keep 'em listening" in your community. It is an important service in wartime. And Mallory will be glad to help, with technical information and answers to the questions you may pose.

**P. R. MALLORY & CO., Inc., INDIANAPOLIS, INDIANA**

**P. R. MALLORY & CO. Inc.**  
**MALLORY**



**Approved Precision Products**

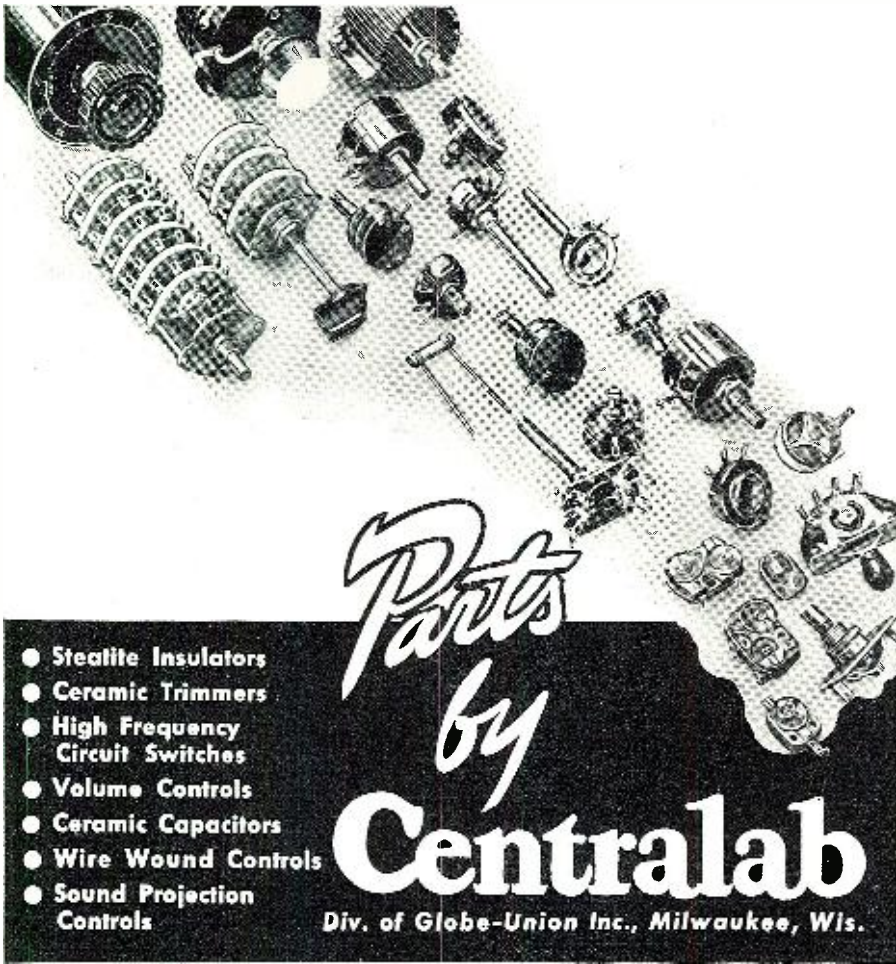

**Parts by Centralab**  
Div. of Globe-Union Inc., Milwaukee, Wis.

- Stealite Insulators
- Ceramic Trimmers
- High Frequency Circuit Switches
- Volume Controls
- Ceramic Capacitors
- Wire Wound Controls
- Sound Projection Controls

## Delay & Timing Circuits

(Continued from page 34)

inductance L. The effect of this charge is to bias the Thyatron grid more negatively and eventually to cut off the flow of anode current. When cut-off occurs, current ceases to pass through the controlled device, and the capacitor discharges slowly through the inductor. The cycle then is repeated at a rate determined by the L and C values.

SYSTEM 8. Direct Thyatron control of devices at a very slow rate is another interesting application of the two-stage circuit consisting of vacuum-tube timer-Thyatron controller. Such an application is the slow dimming, or brightening of lights in response to the depressing of a switch.

In this system, the R and C values in the vacuum-tube timing stage are selected to permit a long control interval and the circuit is arranged to enable either a gradual building up of voltage across a plate load resistor (as in Figure 9), a gradual decay of this voltage, or either of the two which may be selected at will. The lamps, or other devices to be slowly controlled, are connected directly in the anode circuit of the Thyatron tube. (See Figure 9). If a single gaseous tube does not pass sufficient anode current to operate the controlled device, several of these tubes may be connected in parallel for the purpose. Anode voltage is obtained directly from the secondary winding of the transformer T, and half-wave rectified current supplied to the controlled devices in the anode circuit.

### Timing Circuits

It is obvious that several of the circuits already described might be used for timing purposes; i. e., they might be adapted to signal the beginning and end of a certain time interval, instead of for delayed control purposes. Likewise, they might be employed to govern automatically the length of various processes to be timed.

Numerous present applications exist for electronic timing devices. Some of these are the timing of chemical operations and other general laboratory operations; the timing of camera exposures and photo finishing processes; timing of electric welders; generation of time impulses for various scientific instruments, life test operations, etc.

Aside from the circuits already described, which may be adapted to these uses, certain other arrangements have been developed expressly for timing. A few of these will be explained in the following paragraphs.

SYSTEM 1. The simplest electronic timing circuit is shown in Figure 12. This circuit is a type of gaseous tube relaxation oscillator of the most rudimentary variety, nevertheless it is very reliable in operation and is equally inexpensive and compact.

Operation of the circuit is explained

## UNDER 4 FLAGS

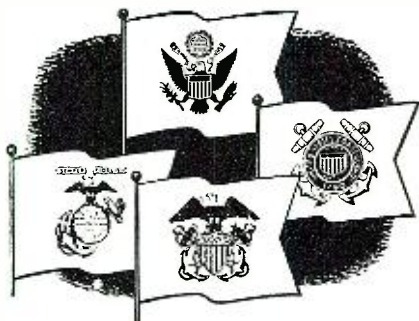

## RIDER BOOKS

are training Radio men

In addition to use as texts in all the armed services, Rider Radio Books are also found in leading libraries and famous technical schools; to mention a few: Georgia Tech., Univ. of Pennsylvania, Northwestern Univ., Virginia Polytech., Manhattan College, M I T, Univ. of Delaware, Carnegie, Duke, Harvard, Syracuse and Univ. of Alabama.

Send Today for New Catalog

**JOHN F. RIDER, Publisher, Inc.**

404 FOURTH AVENUE • NEW YORK CITY  
EXPORT DIV.: ROCKE-INTERNATIONAL ELEC. CORP.  
100 VARICK STREET, NEW YORK CITY. CABLE: ARLAB



## "THE INDUCTANCE AUTHORITY"

By Edward M. Shiepe, B.S., M.E.E.

THE ONLY BOOK OF ITS KIND IN THE WORLD, "The Inductance Authority" entirely dispenses with any and all computation for the construction of solenoid coils for tuning with variable or fixed condensers of any capacity, covering from ultra frequencies to the borderline of audio frequencies. All one has to do is to read the charts. Accuracy to 1 per cent may be attained. It is the first time that any system dispensing with calculations and correction factors has been presented.

Each turns chart for a given wire has a separate curve for each of the thirteen form diameters. The book contains all the necessary information to give the final word on coil construction to service men engaged in replacement work, home experimenters, short-wave enthusiasts, amateurs, engineers, teachers, students, etc.

There are ten pages of textual discussion by Mr. Shiepe, graduate of the Massachusetts Institute of Technology and of the Polytechnic Institute of Brooklyn, in which the considerations for accuracy in attaining inductive values are set forth.

Order from your dealer or direct—\$2.50

## LAWRENCE SLIDE RULES

With A, B, C, D, C1 and K Scales

FEATURES: Nickel Silver Framed Indicator with integral friction springs. Scales calibrated directly on well seasoned wood. Will retain accuracy regardless of temperature or humidity changes.

Instructions and illustrations of primary operations clearly printed on back of rule for ready reference or teaching. Each rule in a durable pocket carrying case for convenience and protection.

LAWRENCE 10 inch white-enameled slide rule with flat magnifier, in black case. Price, including 28-page instruction book... No. 457... 60c  
28-page illustrated book of instructions... No. 459... 15c

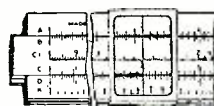

## GOLD SHIELD PRODUCTS

350 Greenwich St., (Dept. RN7), New York City



**THE SKILL *and* THE WILL**  
*... today and tomorrow*

Only one American in many thousands is privileged to wear the "E" pin, symbolic of high achievement on the production front. It symbolizes skill and determination above and beyond the high average standard set by American Industry. The men and women of Connecticut Telephone & Electric Division have been honored by the Army-Navy Production Award twice in a period of six months. This symbol

of a job being well done in the cause of Victory is evidence, too, of what may be expected when the war is won. The manufacturer seeking cooperation in product engineering and improvement, the development of production control, or any problem involving the application of advanced electrical or electronic knowledge, is cordially invited to discuss the matter with our engineering staff.



## CONNECTICUT TELEPHONE & ELECTRIC DIVISION

MERIDEN



CONN.

© 1943 G.A.I., Inc., Meriden, Conn.

**DESIGN, ENGINEERING & PRODUCTION  
 OF PRECISION ELECTRICAL EQUIPMENT**

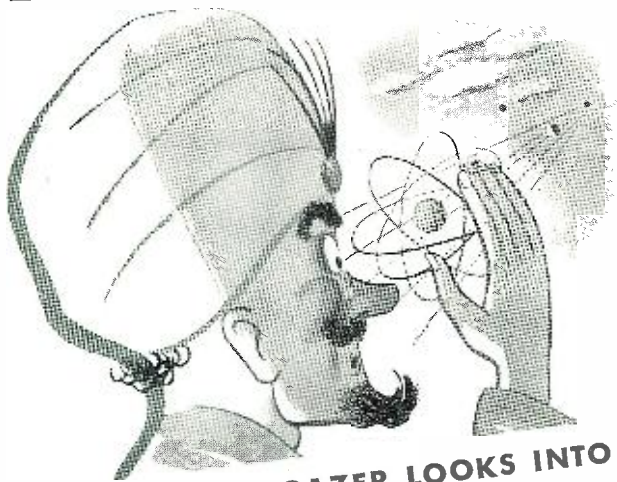

## THE CRYSTAL-GAZER LOOKS INTO AN ATOM

Hocus-pocus with a crystal ball has been replaced by the electron microscope . . . and a host of other devices . . . that really give us a vision of the future. Today's unpublished observations . . . censored by war secrecy . . . will be the basis for tomorrow's industry.

Stancor Transformers are now fighting the war with armies of electrons . . . speeding the energies of military communications. But Stancor engineers are looking ahead . . . through the clearer-than-crystal glass of scientific research . . . to the practical problems of the coming age of electronics.

# STANCOR

STANDARD TRANSFORMER CORPORATION • 1500 NORTH HALSTED STREET • CHICAGO



as follows: Capacitor C is charged by the 100-volt d. c. source. This capacitor charges at a rate determined by its capacitance and the resistance R. When the voltage across the capacitor due to the charging current, reaches the ignition potential of the neon lamp, the latter is fired and the capacitor voltage is thereby reduced sharply until the extinction potential of the lamp is reached, whereupon the neon discharge is extinguished. The circuit is then ready for a repetition of the cycle.

By properly proportioning the values of C and R, the alternate charging and discharging of the capacitor may be set at any desired rate, the relay opening and closing at the same rate. In laying out the circuit, the reader must be careful that the R value be kept such that the sum of the resistance already enclosed in the base of the lamp and the reactance of the relay be half (or less) of the timing resistance.

This circuit may be used to control repetitious operations directly, through the relay, or to signal the start and stop of a given time interval. If the experimenter desires, the relay may be dispensed with entirely, being replaced by a suitable resistance. The drop developed across this resistor by the capacitor discharge current may then be utilized directly to trigger a gaseous triode or tetrode which in turn may control a piece of machinery, recorded, or signal alarm directly in its anode (plate) circuit.

This timing circuit, being by nature an oscillator, may be adjusted to respond at any convenient rate between 1 cycle in several hours to several thousand cycles per second!

SYSTEM 2. A timing system, entirely a. c. operated although including only one tube, is in wide use among amateur photo finishers. This circuit which turns the printing or enlarging lamp on and off, exposing for a predetermined time interval, is shown in Figure 13.

Rt and Ct are the timing circuit elements. The d. c. relay and tube cathode resistor Rk are connected in series in the cathode circuit. Cf is an anti-chatter capacitor for smoothing the r. a. c. cathode current through the relay coil. AC plate and tube heater voltage are obtained directly from the windings of transformer T.

In operation, switch S is thrown to the No. 2 position. The relay picks up at that instant, switching on the lamp. At a later instant determined by the magnitudes of Rt and Ct, the relay drops out, switching off the lamp. S rests in the No. 1 position.

The grid bias voltage, with S in position 1, is the drop produced across the series circuit containing the relay and Rk. This bias drops at the instant S is thrown to position 2, being then equal to the cathode circuit drop less the drop across Rt. The resultant low value permits the plate current to rise to a value high enough to pick up the relay and switch on the lamp.

## Basic Facts on Electricity Needed to Understand Electronics!

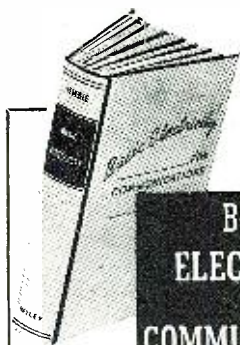

**BASIC  
ELECTRICITY**  
for  
**COMMUNICATIONS**  
by W. H. TIMBIE

A clear, concise, practical book for those who want to prepare themselves now for the rapidly growing fields of Communications and Industrial Electronics.

This book gives you a comprehensive picture of the fundamental laws and principles governing communications practice. You will know the instruments and apparatus used—what they look like—how they work. You will know the symbols and language of the trade, and learn to figure quickly daily problems. This book will give you a foundation that will serve you well at all times and prepare you for advanced work in the field.

603 pages **\$3.50**

ON APPROVAL COUPON

JOHN WILEY & SONS, INC.  
440 Fourth Avenue, New York 16, N. Y.

Please send me a copy of Timbie's BASIC ELECTRICITY FOR COMMUNICATIONS on ten days' approval. At the end of that time, if I decide to keep the book, I will remit \$3.50 plus postage; otherwise I will return the book postpaid.

Name.....  
Address.....  
City and State.....  
Employed by.....

RN-S-43

## CABINETS and RADIO PARTS

LAKE can still supply you with combination, console and table model cabinets, in styles and finishes to suit your requirements.

Our large stock of output and power transformers, capacitors, resistors, volume-controls, by-pass condensers, toggle and slide switches, ballast tubes, speakers and other radio components is now listed in our new Bargain Bulletin. Write for your free copy. Order all the parts you need from one source  
**LAKE!**

### 14" SPEAKERS

14" electro-dynamic speakers. 900 ohm field, 6—8 ohm voice coil. 6V6 push-pull transformer. 15 watt output. **\$4.49**  
Special, only.....

### 3 1/2" SPEAKERS

3 1/2" square shape P.M. speakers with 4 ounce magnet. **\$1.15**  
Special, only.....

### Still Available!!

3" to 12" Dynamic Speakers  
(Any desired field)  
3" to 12" P.M. Speakers

New Bargain Bulletin lists Money Saving Values in Radio Parts. Send for it TODAY!

**LAKE RADIO SALES CO.**  
615 W. Randolph St. Chicago



**New  
IRC  
WARTIME  
AID!**

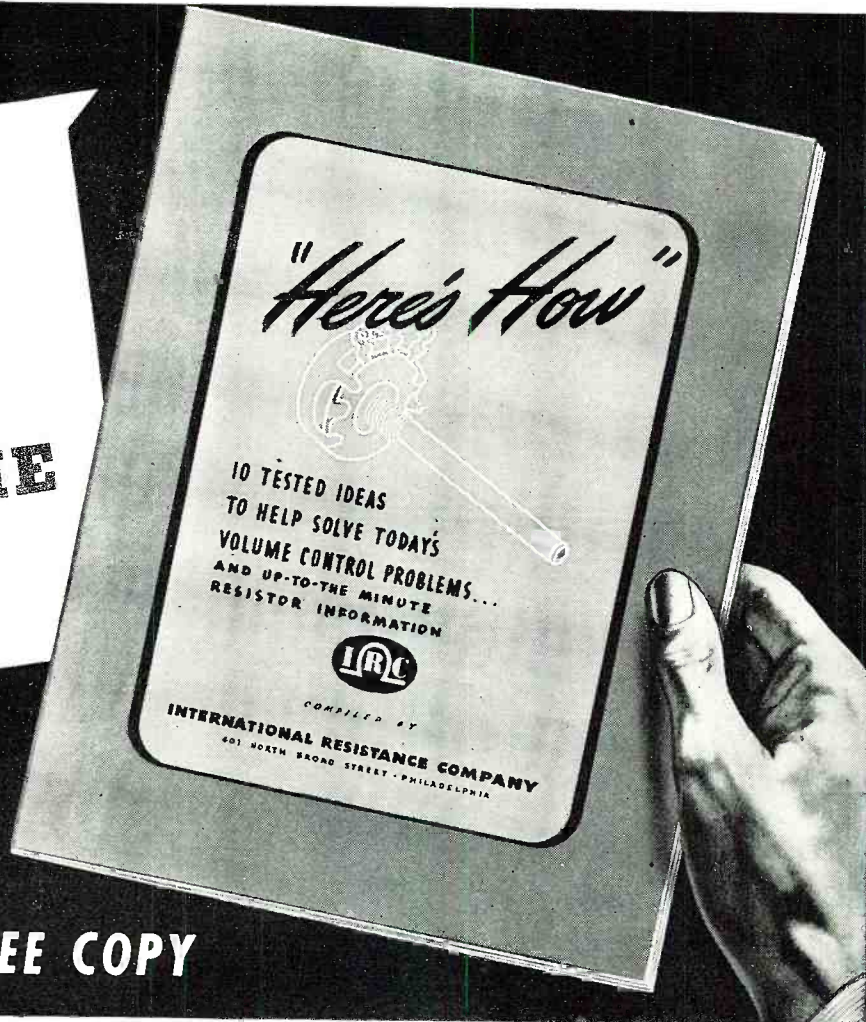

**WRITE FOR  
YOUR FREE COPY**

Remember the "Here's How" contest, recently sponsored by IRC in leading Service Papers throughout America? . . . Hundreds of Service Men sent in their suggestions on how to replace volume controls and get radio sets working satisfactorily when the controls which normally would be used were not available.

The contest judges had a tough job picking the winners and the runners-up. Piles of letters had to be read—diagrams checked. But now it's all in shape and we've put the *ten top ideas* in a booklet to help everyone in the industry faced with a volume control problem. As an added feature we've included the latest data on ½, 1 and 2-Watt Resistors (both Metallized and Wire-Wound), together with substitution information on 10-Watt Wire-Wound Resistors, now so difficult to obtain.

*These booklets are so timely and so useful to Service Men that we don't think our supply will last very long. May we suggest that you write today for your copy? No charge, of course.*



**CLIP AND MAIL THIS COUPON TODAY**

**INTERNATIONAL RESISTANCE COMPANY**  
401 N. Broad Street, Philadelphia 8, Pa.

Gentlemen:

Please send me a copy of your new "HERE'S HOW" booklet.

(Please Print Name and Address)

NAME \_\_\_\_\_

COMPANY \_\_\_\_\_

ADDRESS \_\_\_\_\_

CITY \_\_\_\_\_ STATE \_\_\_\_\_

My Regular Distributor is

RN

The voltage drop across  $R_t$  decreases as  $C_t$  continues to charge, the negative bias thereby increasing until the decaying plate current drops out the relay and switches off the lamp.

\* \* \*

Various timing circuits, either of the simple vacuum-tube type or the more complex arrangements employing gaseous triodes or tetrodes, may be employed to control rapidly the on-time and off-time of electric welders.

Resistance and spot welders may thus be arranged to operate during any length of time during a single a. c. cycle or up to an interval several cycles in length. This action is accomplished chiefly by exciting the control and regulator tubes with alternating voltage so that the conducting time of the heavy-current gaseous control tubes may be regulated over portions of the excitation cycle.

-30-

## Variable Inductors

(Continued from page 44)

switch blade and closely-spaced switch contact points. Tapped coils are successfully employed in transmitters in which the inductance tapping is not carried over too wide a range, provided the current is switched off while the coil switch is rotated.

## Variometer

The variometer consists of two coils placed in inductive relation with each other. One coil is stationary, while the other is made variable, rotating within the stationary member. In one position, the field of one coil cancels the other, reducing the resultant inductance, while in the other extreme position, the two fields aid each other. Between these limits, various degrees of interaction are obtained, yielding various values of inductance.

The variometer is illustrated in Figure 4. The rotating coil is mounted within the stationary coil; while in another arrangement, the variable slides in and out of the fixed coil. In either arrangement, the two coils may be connected either in series or in parallel with each other. The standard symbol for the variometer is shown in Figure 5.

The variometer is continuously variable and is smooth in action. Although it offers a slightly more difficult constructional problem, its obvious advantages recommend it to many critical uses. Laboratory standards of inductance are almost always variometers when the variable feature is a requirement. Variometers may readily be ganged for single dial control and may be tracked by adjusting the angle of rotation for individual rotating coils.

The variometer chosen for the writers measurements is shown in Fig. 4. It is a small unit, consisting of a stationary coil wound on a bakelite tube, and rotating coil wound on a concentric

# THE LITTLE MAN IN THE PEANUT

Remember when, as a kid, your mother would open a roasted peanut and solemnly say, "Here's the peanut man"? Sure enough, there was a gnome face with stocking cap and long beard. You wondered how he got there but, as time passed, you forgot all about him.

Years went by. You graduated, got a job, married, and the children came along. Then, when you were securely established, the war broke. For many reasons, you couldn't get into active service . . . so you entered civilian defense, and worked like hell at it.

People spoke of rationing, priorities, a second front and inflation. Those things concerned you but, somehow or other, you'd grown used to the war and its impositions.

Without realizing it, you were becoming more and more like the little man in the peanut. No one put you there . . . the shell of complacency grew around you . . . and only occasionally did a familiar name on a casualty list jar you from your apathy.

'Tis said that this will be a long war. If that's the way you want it, that's the way it will be. Need it be? You . . . yes, you . . . have the power to help shorten the war. You have the power to hurry the boys home. If you can't say today that you've done as much to win the war as you promised on December 7th, 1941, you'd better crawl out of that shell, brother, and produce!

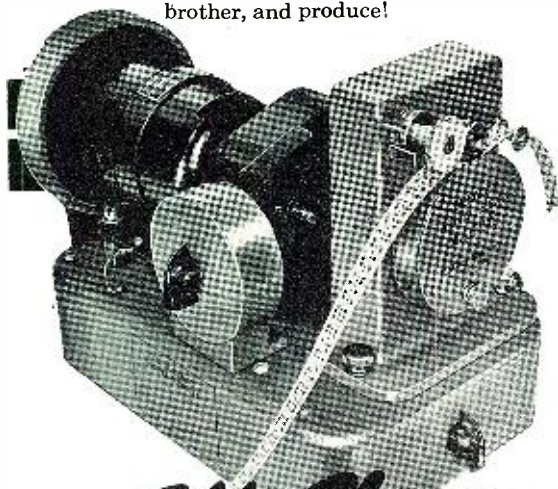

Day and night McElroy High Speed Radiotelegraph Equipment is in there pitching. On the home and battlefronts, this apparatus is rushing the transmission of news, messages, orders. As creative telegraphic engineers, we are doing our share . . . delivering better telegraph apparatus.

**McElroy**

**MANUFACTURING CORP.**  
82 BROOKLINE AVE. BOSTON, MASS.

The *First* Real Forward Step  
in Radio Design—Since development  
of the superheterodyne circuit

**4-cell HARVEY  
Scout-car Receiver**

Quickly assembled from standardized cells is this scout-car type receiver: it has two R. F., one I. F., and one Audio units. If greater sensitivity or selectivity were desired, additional cells could be assembled to the basic receiver.

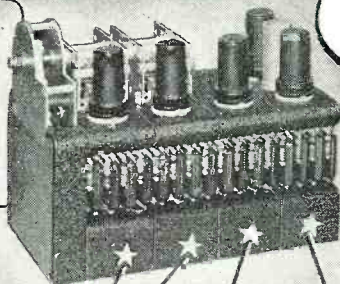

The  
**HARVEY**  
*"Unitized"*  
**COMMUNICATION  
RECEIVER**

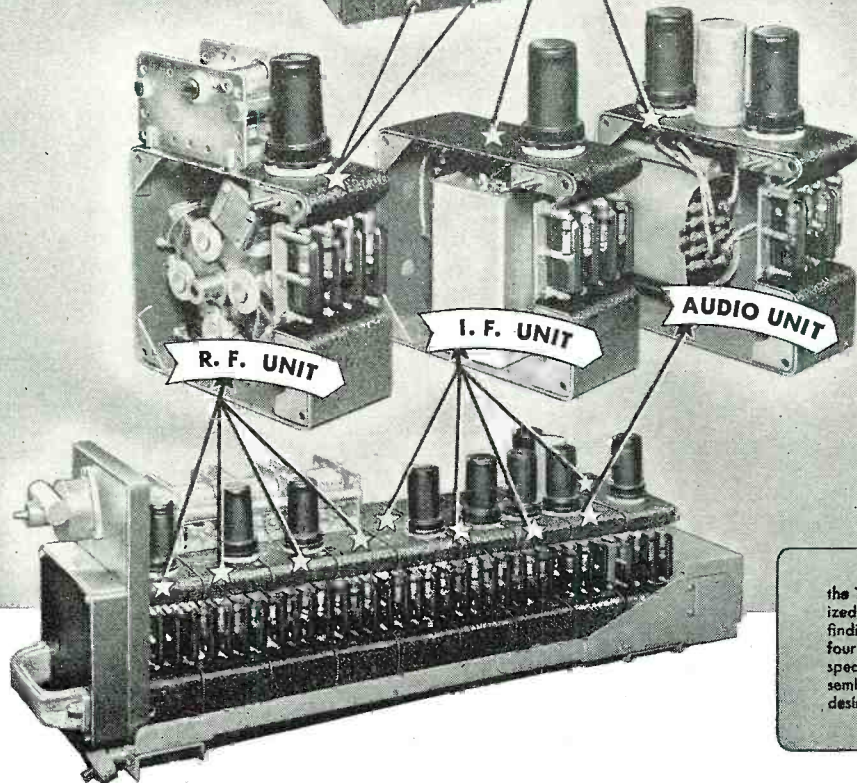

**From the  
3 Basic Units**

the 10-cell HARVEY aircraft receivers of Unitized construction provide automatic direction finding, and loop or antenna reception on four frequency bands; built to Signal Corps specifications. Power supply could also be assembled from standardized Harvey cells, if desired.

REVOLUTIONARY in eliminating critical materials, reducing tube types to only ONE, effecting savings in assembly and servicing time — the HARVEY Unitized construction makes possible custom-built performance by production methods. Among the vitally important features are: reduction of hook-up wire to as little as five feet, in comparison to over one hundred feet commonly used in many communication receivers; reduction in tube types from the usual minimum of six to only ONE; quick assembly and servicing since there are only three basic cell-units; elimination of large spare parts stocks and need for "experts" to make field repairs since complete cells can be as quickly replaced as a tube in ordinary receivers, in event of damage to individual cells.

For the first time, receiver manufacturing is truly put on a production line basis, as a result of *this* Harvey development.

*Electronics Division*  
**HARVEY**

**MACHINE CO., INC.**

6200 Avalon Blvd.  
Los Angeles, Calif.

**OTHER HARVEY DIVISIONS  
AIDING THE UNITED NATIONS**

**AIRCRAFT DIVISION  
ORDNANCE DIVISION  
SPECIAL MACHINERY DIVISION**

# CRYSTALS

BY

**DX  
XTALS**

the heart of a good transmitter

Ample production facilities available for lots or individual crystal orders—Priorities, of course.

Buy More Bonds!

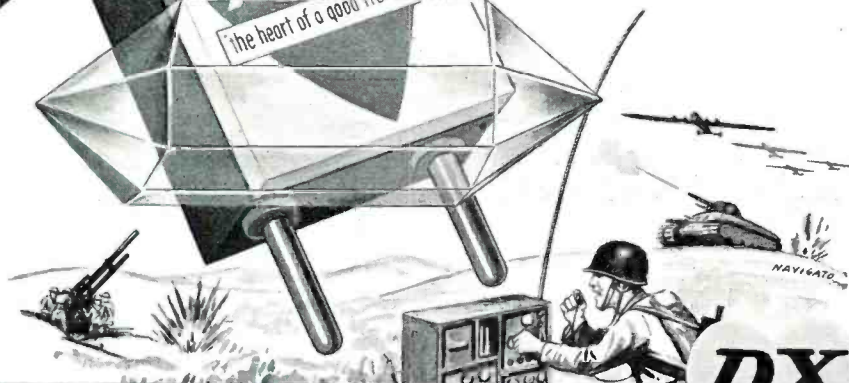

**DX CRYSTAL CO.**

GENERAL OFFICES: 1841 W. CARROLL AVE., CHICAGO, ILL., U.S.A.

**DX  
XTALS**

the heart of a good transmitter

TRADE MARK

wooden spool, varnish treated. The coils were arranged for connection either in series or parallel for the tests. The following data were taken: Minimum Inductance (Coils in Series) 0.02 mh. Q 46. Maximum Inductance 0.05 mh. Q 47. Minimum Inductance (Coils in Parallel) 0.0042 mh. Q 67. Maximum Inductance 0.012 mh. Q 70.

Variometers manufactured for laboratory use offer inductance variation as great as 8 to 1 for the series coil connection and as great as 10 to 1 for the parallel connection.

### Powdered-Iron Cores

Introduction of a powdered core into the center of a coil increases its inductance and Q by an amount depending upon the position of the core. This type of inductance variation has been in use for some time in the tuning of receiver r.f. and i.f. stages. When the iron core is arranged mechanically so as to be moved in and out of the coil, as by means of a cam and tuning dial, smooth variation of inductance may be obtained, and a band of frequencies may be covered. In fixed-tune circuits, such as i.f. transformers, the powdered-iron core may be arranged to be screwed in and out of the coil.

The writer selected for test a commercially-built lattice-wound coil with Polyiron type core. The coil, shown in Fig. 6 (left), is wound on a thin-walled bakelite sleeve. The core is snug fitting and adapted for movement by means of screw adjustment.

The following measurements were made with the coil described above in a standard commercial Q-Meter: Maximum Inductance (core in) 72.40  $\mu$ h. Q 240. Minimum Inductance (core out) 27.78  $\mu$ h. Q 139. This represents an inductance variation of better than 2.5 to 1 for the small-size coil tested. A wider variation might be obtained by winding a long coil and providing a long core.

Powdered-iron cores have found greatest utility in trimming resonant circuits over a small frequency range. Examples of this application are in i.f. transformers, pushbutton-tuned r.f. circuits, and other positions in which a fixed condenser sets the circuit to an approximate frequency, exact trimming being left to the core. Powdered-iron-core tuning is not recommended for circuits in which large amounts of r.f. current flows during normal operation.

### Metal-Slug Tuning

If a non-ferrous metal plunger or slug is substituted for the powdered-iron core, the coil inductance may be varied in the reverse manner. That is; when the plunger is entirely within the coil, the latter's inductance will be less than before. This type of tuning may be arranged mechanically in the same manner as core-tuned systems.

Action of the plunger-tuned coil is based upon losses within the plunger, which effectively reduce the inductance of the coil. This method is attendant with large losses, however, and is not widely used for that reason,

YOUR CHOICE OF  
*4 Impedances*  
with  
**TURNER U9-S**



Get 50-200 or 500 Ohms, or Hi-Impedance at a Twist of the Switch

Turner U9-S is a rugged dynamic that does the job of four mikes. Adjustable to semi- or non-directional operation, with a level of -52 DB at high impedance. Response is free from peaks and holes from 40 to 9000 cycles. Be sure of your ability to handle any job

with U9-S. Send for your FREE Copy of Turner's new Catalog.

**The TURNER Co.**  
Cedar Rapids, Iowa



### NEW Test Lead

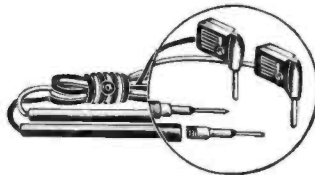

This new ICA Test Lead (No. 373) is approved by the Signal Corps. Preferred by leading test equipment manufacturers.

Mfrs. and Contractors, write for this 12-page Industrial Catalog.

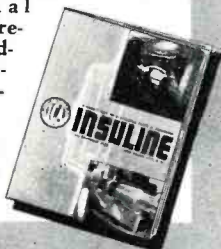

**INSULINE**  
CORPORATION OF AMERICA  
INSULINE BUILDING  
(36-02 35th AVENUE)  
LONG ISLAND CITY, N.Y.

Manufacturers of quality electronic components for 10 years

### THE ANSWER TO BAND-SWITCHING PROBLEMS



A typical B & W Turret  
Coil Assembly

Over 90% of our inquiries on band-switching problems can be solved by standard B & W Turret Coils—*better, and more efficiently than by any other means!* For greatest efficiency in the selection and use of Turret Coils, we suggest that you consult B & W engineers on your basic equipment design. A wealth of specialized engineering experience is freely at your disposal.

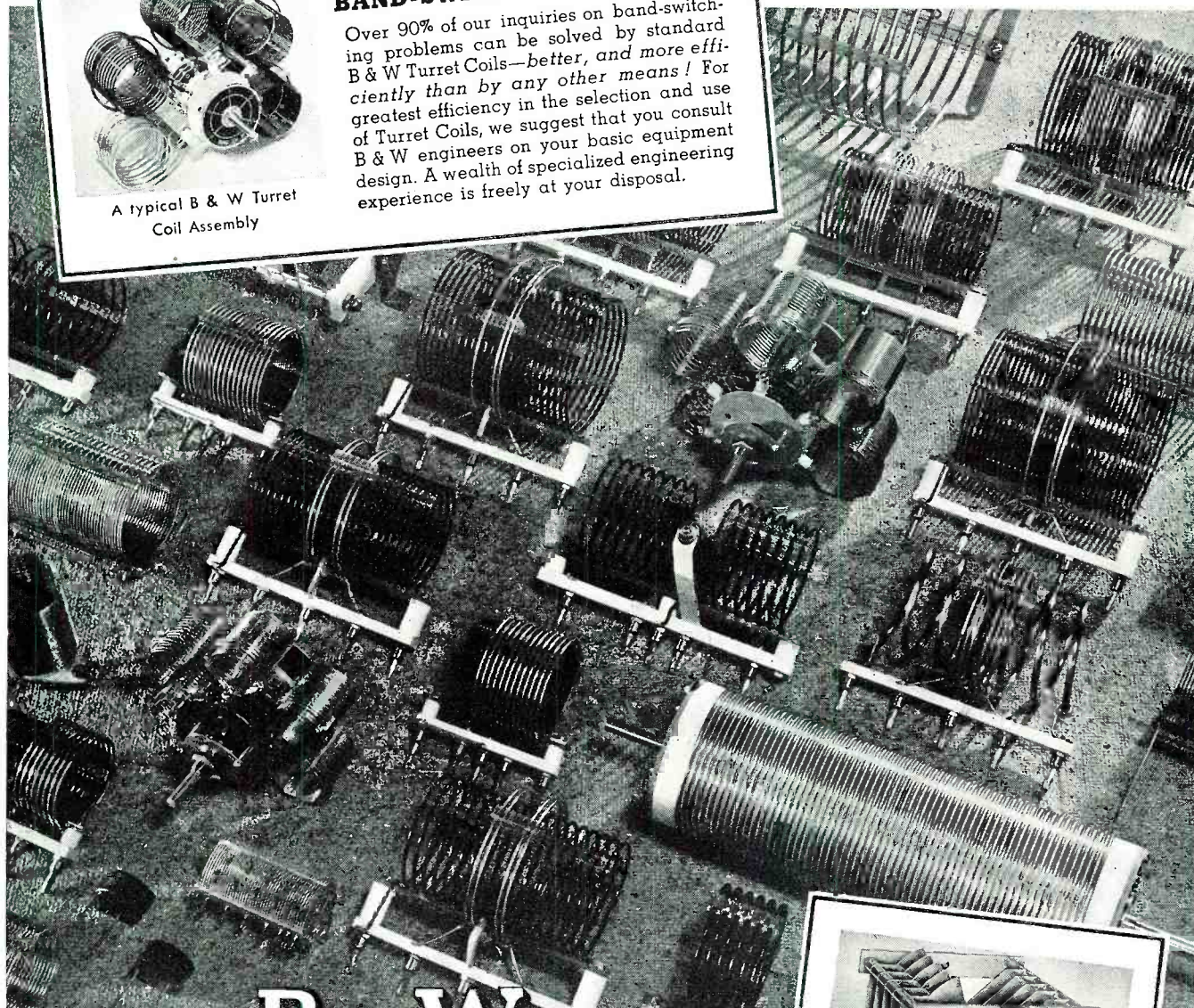

# B & W

## AIR INDUCTORS and VARIABLE CONDENSERS

Big ones — little ones — standard units — specials — and "super specials" for the nation's "fightenest" services! . . . that, in brief, is the story of B & W Air Inductor Coils.

If it's a Coil, chances are, we can supply it—built with well-known B & W precision—and produced promptly, thanks to the fact that B & W engineers were the first to produce Coils by modern line production methods. Literature and full details of any type on request. Samples to your specifications. Write, wire, or 'phone today!

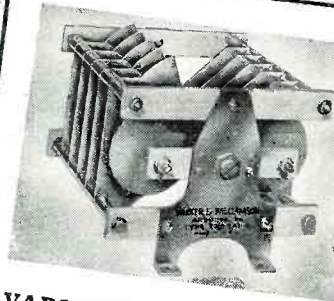

### VARIABLE CONDENSERS FOR HIGH-POWER USES

Shorter than conventional units, and having built-in neutralizers and coil-mounting feature, B & W Variable Air Condensers meet the highest performance standards. Other features include perfect electrical symmetry; Alsmag 196 insulation throughout; low distributed inductance; low minimum capacities; and many more. Technical Data Sheet upon request.

**BARKER & WILLIAMSON · 235 Fairfield Ave., Upper Darby, Pa.**

# Now RIG D TERMINALS

(Patent Pending)

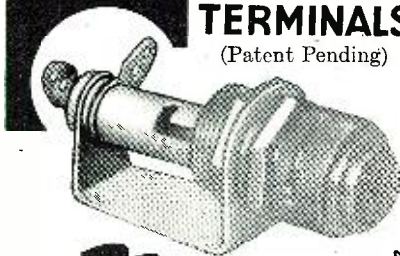

by *New*..

## GOTHARD PROCESS

Again Gothard pioneers in Pilot Light design and construction by providing vibration and turn proof terminals. Terminals on all Gothard Pilot Lights are rigidly fastened in place and cannot loosen or turn to cause shorts. This is only one of the many individual features that have resulted from Gothard's careful study of field requirements. Gothard Pilot Lights are available in a wide range of sizes and styles, all of which are illustrated and fully described in the Gothard Pilot Light Assemblies Catalog.

THEY ARE LOCKED IN POSITION

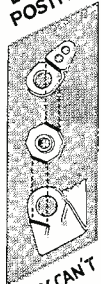

THEY CAN'T TURN OR SHORT

Request your copy without obligation.

**Gothard** . . . .  
**MANUFACTURING COMPANY**  
 1350 N. NINTH STREET, SPRINGFIELD, ILLINOIS

# TRIPLETT

*Combat Line*

## TESTERS

Pocket Size  
 MODEL 666H



VOLT-OHM-MILLIAMMETER

Although some older designs are no longer obtainable, several alternate models are available to you under Government requirements.  
 TRIPLETT ELECTRICAL INSTRUMENT CO., BLUFFTON, OHIO

although it has been employed for trimming purposes in some receiver circuits from time to time.

In spite of its relative inefficiency, the plunger-tuned coil may readily be applied in emergencies when variable condensers are not available for trimming circuits or for tuning over narrow frequency bands. Because of its high eddy current losses, however, this type of inductance variation is not recommended in circuits, such as in transmitters, where large values of r.f. current normally flow through the coil.

### Disc-Tuned Coils

Inductance variation over a limited range may be secured by means of a small non-ferrous metallic disc arranged, as shown in Figure 6 (right), to be moved in and out of a coil. Action is very similar to inductance variation by means of a metallic plunger, just described.

The tuning disc is generally constructed of brass or copper and is cut to a diameter slightly less than the inside diameter of the coil form. It may be arranged to travel along a long screw mounted to the end of the coil form, or may be inserted into the form by means of an arm controlled by a dial mechanism.

As the disc moves toward the center of the winding length, the inductance of the coil decreases, reaching its lowest value when the disc is at the exact center of the winding. From then on, the disc is again moving out of the coil, although continuing to move in the same direction, and the inductance increases, reaching the original maximum when the disc is entirely free of the other end of the winding. The maximum inductance range thus is obtained between the center of the winding length and one end of the coil.

### Shield-Tuned Coil

Applying the principle of eddy current loss to inductance variation by means of external non-ferrous metallic members arranged within the coil field, we may obtain an "external version" of the plunger—and disc-type tuner systems. This arrangement, illustrated in Figure 7, utilizes a shield sleeve which is moved over the coil to vary its inductance over a narrow range.

### Ring-Tuned Coil

Another type of lossier tuning widely employed in trimming receiver circuits at high frequencies, makes use of a short-circuited ring. This is shown in Figure 8.

A non-ferrous metallic ring, somewhat smaller in diameter than the coil, is arranged to rotate within the coil. The inductance variation obtained with this type of tuning is very slight, suitable for narrow-range circuit trimming at relatively low frequencies. Q reduction is considerable, being comparable to that occasioned by introduction of metal plungers, discs, or shields within the coil field.

-30-

# RADIO PARTS LOWEST PRICES!

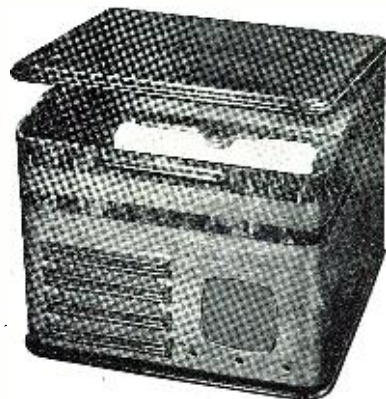

## Combination Table Cabinet

Modern table type phono cabinet, highly finished walnut. Dimensions: 14" front to back, 16" side to side, 5 1/2" bottom of table panel to top, height over all, 13".

In original cartons—while they last. . . . . **\$7.95**



## NEW PHONO MOTOR

Model CX 78 RPM. Gear Driven. 9" turntable. Quiet operation. Powerful synchronous motor, rubber insulated from turntable. Positive direct drive through silent helical cut gears sealed in oil. Depth from mounting plate to bottom 3 1/8".

Special now at. . . . . **\$6.45 each**

**RECORDING DISCS!** Thousands of Bristol base acetate coated discs . . . amazingly good quality at lowest price for quick sale . . . minimum background noise—coated on 2 sides—non-inflammable . . . With Labels.

6 1/2" in lots of 10. <b>57c</b>	in lots of 100. . . <b>\$5.50</b>
8 " in lots of 10. <b>77c</b>	in lots of 100. . . <b>7.50</b>
10 " in lots of 10. <b>97c</b>	in lots of 100. . . <b>9.50</b>

## SPECIAL RESISTOR ASSORTMENT

1/4-1/2-1-2-3 wt. ALL VALUES—R. M. A. Coded-100. . . . . **79c while they last.**

## SERVICEMEN'S SPECIAL!—10

lbs. Radio Parts Kit. Consists of all usable radio parts. . . . . **only \$2.95**

**FREE!** Servicemen write today for free catalog listing thousands of parts bargains . . . hardware and replacement parts.

We Save You Money  
 Drop a Post Card Today

## RANDOLPH RADIO

609 WEST RANDOLPH ST., CHICAGO, 6, ILL.

"Millions of Parts for Millions of Radios"



PHOTO BY U.S. ARMY SIGNAL CORPS

## PRACTICE MAKES PERFECT

How many sacks of flour does an attack Bomber drop on friendly tanks? How often does a Tank Commander draw a bead on a friendly plane? How long must Air and Armored Forces flex their muscles together in practice before they become welded in a coordinated striking force?

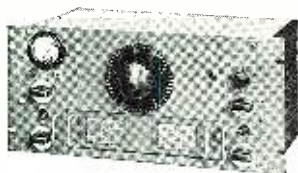

**NATIONAL COMPANY, INC.**  
MALDEN, MASS., U.S.A.

Know-how takes time to acquire. We are thankful that National had years of radio communications know-how all ready.

## Book Review

(Continued from page 40)

presented in clear and concise manner and are so arranged that they serve as a convenient and instant reference. It is a valuable adjunct to classroom study and library work for the student and instructor. It saves considerable time and is ideally suited to the radio amateur, technician and engineer both in the library and in the field of operations.

**"HENLEY'S TWENTIETH CENTURY BOOK OF FORMULAS, PROCESSES AND TRADE SECRETS,"** by Prof. T. O'Connor Sloane, A.B., A.M., E.M., Ph.D. Published by *The Norman W. Henley Pub-*

*lishing Company*, 17-19 West 45th Street, New York City. 861 pp. plus index. Price \$4.00.

The publishers have prepared this new edition in response to a demand for this type of book which includes many new formulas and deletes those that have become out of date. The new edition contains a glossary of chemical terms and their corresponding names and several pages of useful information concerning the materials required in compounding formulas. The Editors have endeavored to meet the requirements of the home and workshop, the artisan and the general home worker. Many formulae are included which apply to the product of various types of communications equipment. These include formulas

on paints, lacquers, varnishes, etc. Furthermore, it covers completely formulas used for chromium plating and others used in the radio industry.

**"RADIO NETWORKS AND THE FEDERAL GOVERNMENT,"** by Thomas Porter Robinson. Published by the *Columbia University Press*. 278 pp. Price \$3.50.

This book covers a comprehensive history of network broadcasting and of its relationships to the Federal Government. The subject, which is of self-evident importance to everyone in any way connected with the radio industry, also concerns every citizen both as voter and as listener. This book presents an engrossing panorama of the development of the industry and its amazing ramifications from the beginnings of wireless telegraphy, through the day, less than a quarter of a century ago, when station KDKA inaugurated regular broadcasting (from a studio in a small garage), down to the present era of national networks. While not a technical book, it serves its purpose well by bringing to executives and engineers a knowledge of the backbone of broadcasting as we have it today.

**"PRINCIPLES AND PRACTICE OF RADIO SERVICING,"** by H. J. Hicks, M.S. Second Edition. Published by *McGraw-Hill Book Company, Inc.*, New York and London. 380 pp. plus index.

This new book is a compilation of basic servicing methods whereby the radio servicemen may become familiar in general fashion with the hundreds of various models of radio receivers now on the market. It is very clearly written and profusely illustrated.

One chapter deals with the servicing of radio receivers and gives the student very complete instructions as to the proper use of tools in the service shop. Of particular interest to the radio serviceman is the chapter devoted to the business side of radio servicing. It shows the pitfalls when improper methods are used in conducting one's business and suggests many ways in which the serviceman's revenue may be increased. This book will make an excellent addition to any serviceman's library.

**"ELEMENTS OF RADIO,"** by Charles I. Hellman. Published by *D. Van Nostrand Company, Inc.*, 250 Fourth Avenue, New York City. 307 pp. Price \$2.00.

This book was written to meet the requirements of the pre-induction training course in fundamentals of radio as set forth in the *War Department* outline, PIT 201. It is designed to serve as a full year course in the first study of radio principles and it assumes that the student has had no previous knowledge of radio. Quantitative aspects of radio are given careful treatment. Each new formula is explained and implemented by one or more worked-out examples which are immediately followed by problems to be solved by the student. At the end

# SOMARON WANTED PRIME AND SUB-CONTRACTS

We can fulfill contracts on scheduled time. Submit your problem to us. Here is a partial list of our machinery.

3 Welders  
2 Square Shears  
5 Brakes  
4 Rollers  
2 Crimper  
Unishear  
Seamer  
Cir. Shear  
8 Kick Presses  
Punch Press  
2 Alligator Shears

Angle Shaper  
Hammer  
Thick Edgerer  
3 Flex. Grinders  
Abrasive  
Miller  
Hack Saw  
Drill Press  
Engine Lathe  
Angle Shear

## SOMARON

### METAL FABRICATORS

ESTABLISHED 1901

434-440 EAST 165TH STREET

NEW YORK, N. Y.

**MICROPHONES ★ PLUGS ★ SWITCHES**

GOVERNMENT SPECIFICATION ITEMS

AR-1M	PL-54	SW-141
CU-1	PL-55	SW-217
CU-2	PL-291	CD-318
1700-U	JK-26	CD-508
PL-68	JK-48	M-199

PROMPT DELIVERIES

**UNIVERSAL MICROPHONE CO., LTD.**  
INGLEWOOD, CALIFORNIA, U. S. A.



**AT TREMENDOUS SACRIFICE FOR SALE NEW AND SLIGHTLY USED ALL IN A-1 CONDITION**

- 600 Code Keys, McElroy, Brach, Navy, Signal, Bunnell, Speedex, etc. . . . . For lot **\$600.00**  
Or catalog price for lots of one.
- 20 "Original" Vibroplex . . . . . For lot **120.00**  
Or Catalog price for lots of one.
- 400 Ear Phones, Cannon, Brandies, Trimm, Brush, Philmore, I.C.A., etc. . . . . For lot **500.00**  
Or Catalog price for lots of one
- 26 Code Transmitters & Tape Puller combinations, McElroy. Cost us \$3000. . . . . For lot **1040.00**  
Each in lots of one **50.00**
- 1 Tape Printer, McElroy . . . . . **75.00**
- 4 Code Transmitters, Teleplex. . . . . For lot **120.00**
- 1 Cheaper Teleplex. . . . . **15.00**
- 400 Phone Jacks. . . . . For lot **40.00**  
Or Catalog price for lots of one.
- 10 Signal Code Oscillators, I.C.A. . . . . For lot **40.00**  
Or Catalog price for lots of one.
- 10 Code Practice Oscillators, Factory made. For lot **30.00**  
Each in lots of one **6.00**
- 50 Blank Code Tape Reels for McElroys. . . . . **10.00**
- 48 Printed Takes for McElroys . . . . . **50.00**
- 1 G. C. Marine Compass No. 101, Metal case and antenna wheel, Dane. . . . . **125.00**
- 1 G. C. Marine Compass, Wood case—Wood enclosed antenna. . . . . **100.00**
- 304 Code Practice Tables with typewriter wells and racks for hanging ear phones. Two positions to a table. Beautifully made. Cost us \$28.00 per table. . . . . Per table **10.00**
- 1 Transmitter 4A-B1281, Collins. . . . . **175.00**
- 1 Transmitter 30-FXB, Collins. . . . . **300.00**
- 1 Transmitter C-36, National. . . . . **75.00**
- 1 Transmitter UAT-4, Utah. . . . . **125.00**
- 1 Transmitter SC-101, Utah. . . . . **100.00**
- 1 Transmitter 60-P, Stancor. . . . . **100.00**
- 1 Transmitter T-22K237, Thordarson. . . . . **75.00**

**Scientific Equipment:** 11 Compass Supports; 80 Cats Furs; 5 lbs. Silk Cloth; 1 Weleck static electricity demonstrator; 35 8" straight Bar Magnets; 32 straight Bar Magnets; 42 large Horse Shoe Magnets; 4 small Horse Shoe Magnets; 80 Hard Rubber Rods; 40 Glass Rods; 100 Pith Balls; 100 Magnetic Compasses; 3 lbs. Iron Filings.

Our cost \$400.00, will sell as a lot for **\$250.00**, or in lots of one at catalog prices.

**Tools:** 18 Radio Wrench Sets; 10 Radio Wrench Sets; 6 Alignment Pencils; 2 Neutralizing Tool Kits; 25 Pocket Knives; 2 Stilson Wrenches; 25 Cutting Pliers; 7 Long Noze Pliers; 21 Wire Brushes; 10 Hack Saws with Blades; 1 Compass Saw; 2 Radio Chassis Bunches; 1 set Metal Drills, etc.

Our cost \$262.00, will sell for. . . . . **\$125.00**

731 Miscellaneous Condensers. Our cost \$323.00. Will sell for. . . . . **150.00**

1000 Miscellaneous Resistors. Our cost \$288.00. Will sell for. . . . . **125.00**

66 Miscellaneous Transformers. Our cost \$203.00. Will sell for. . . . . **103.00**

22 6-volt Exide Storage Batteries; 24 452 Large Batteries; 50 Misc. Batteries. Our cost \$541.00. Will sell for. . . . . **200.00**

- 1 Transmitter, Utah, assembled by us, 5 racks. . . . . **\$50.00**
- 1 Test Speaker Hickok. . . . . **30.00**
- 1 Station Allocator Model No. 171, R.C.A. . . . . **10.00**
- 1 Vac. Tube Voltmeter Peak AC Model 88, Clough Brengle. . . . . **30.00**
- 1 Resistance analyser, IRC. . . . . **5.00**
- 1 Multi-Range AC ammeter Mod. J, Precision. . . . . **15.00**
- 1 Battery Charger, Tungar. . . . . **10.00**
- 3 AC Vacuum Tube Voltmeters Model 669, Weston For lot **40.00**  
Or Each in lots of one. . . . . **20.00**
- 2 Microfarad Meters, Models 780, 372, Weston. each **15.00**
- 1 DCMA, Model GSP 500-500, Roller-Smith. . . . . **25.00**
- 1 Wobulator, Model 81, Clough Brengle. . . . . **20.00**
- 1 Wobulator, Model 151, Dumont. . . . . **35.00**
- 1 Wobulator, Model TMV-219-A, RCA. . . . . **25.00**
- 2 Tubular Variable Resistors 48 ohms, 10,082 ohms. Each **5.00**
- 1 Wattmeter, Westinghouse. . . . . **30.00**
- 3 Dynamic Demonstrators No. 2, R.C.A. . . . . For lot **150.00**  
Or Catalog price for lots of one.
- 1 Dynamic Demonstrator No. 1 (Large Size), R.C.A. **125.00**
- 1 Variac Type 100R—0-230 volts Gen'l Radio. . . . . **40.00**
- 20 heavily constructed work benches 9'x12', 36" high. Cost us \$2000. Not sold individually. Lot **1000.00**
- 16 Speakers to be sold as a lot on premises only.
- 5 Amplifiers to be sold as a lot on premises only.
- 8 Microphones to be sold as a lot on premises only.
- 60 lbs. Solder to be sold as a lot on premises only.
- 378 Brand new miscellaneous text books to be sold as a lot on premises only. Our cost \$834.00.
- 230 Stand Offs. . . . . **60.00**
- 125 D.P.D.T. Switches. . . . . **25.00**
- 125 S.P.D.T. Switches. . . . . **20.00**
- 135 S.P.S.T. Switches. . . . . **15.00**
- 72 Folding Chairs. . . . . **125.00**

42 Soldering Irons. Our cost \$74.00. Will sell for. . . . . **\$35.00**

15 Types of Wire in various lengths. Cost \$125.00. Will sell for. . . . . **75.00**

625 Misc. Tubes. Cost \$770.00. Will sell for. . . . . **450.00**

1 Weston Thermo Ammeter, Model 425. . . . . **15.00**

1 Weston Thermo-Galvanometer. . . . . **15.00**

56 Cheap meters, Read Rite, etc. . . . . **25.00**

9 D. C. (all low ranges) Ammeters. Cost \$80.00 Sell for **50.00**

12 AC Milliammeters, Weston, Triplett & Jewell Cost \$143.50. Will sell for. . . . . **135.00**

105 DC Milliammeters. Cost \$1,115.00. Will sell for **1000.00**

27 DC Voltmeters. Cost \$260.00. Will sell for. . . . . **225.00**

35 AC Voltmeters. Cost \$530.00. Will sell for. . . . . **500.00**

15 Multimeters. Cost \$712.00. Will sell for. . . . . **600.00**

3 Capacitor Analysers. Cost \$118.00. Will sell for. . . . . **109.00**

12 Tube Analysers. Cost. \$385.00 Will sell for. . . . . **300.00**

14 Tube Testers, including 5 Simpson, Model 325, 3 R.C.A., Model 156 D & B, 2 Precision, 1 Jackson, 1 R.C.P., 1 Triplett. Cost \$754.00 Will sell for **600.00**

22 Signal Generators. Cost \$1300.00. Will sell for. . . . . **900.00**

20 Scopes. Cost \$1800.00. Will sell for. . . . . **1500.00**

**Above Equipment to Be Sold F.O.B. Warehouse**

**For Information—Contact R. G. DOUGHERTY 786 Broad St., Newark, N. J.**

**FIRST COME—FIRST SERVED!**

**QUALITY  
ABOVE ALL...**

**SOLAR**

**CAPACITORS**

**DRY ELECTROLYTICS**  
**WET ELECTROLYTICS**  
**PAPER CAPACITORS**  
**MICA CAPACITORS**  
**"ELIM-O-STAT" SUPPRESSORS**  
**CAPACITOR ANALYZERS**

**SOLAR**

**MANUFACTURING CORP.**  
**Bayonne • New Jersey**

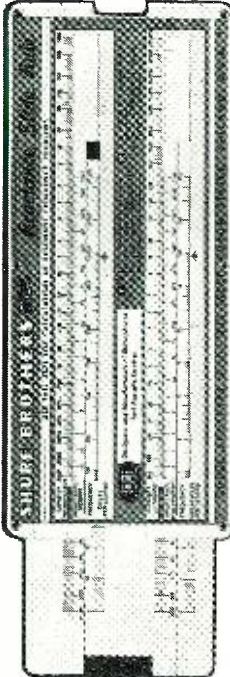

**have you  
sent for  
your SHURE  
REACTANCE  
SLIDE RULE?**

Thousands of engineers and technicians find the Shure Reactance Slide Rule helpful in radio computations. Simplifies problems in resonant frequencies, circuits, inductances, condensers. Range 5 cycles per sec. to 10,000 megacycles. Complete with instructions. Send 10c in coin to cover handling.

**SHURE BROTHERS**  
**225 W. Huron St., Chicago**  
 Dept. 174X

Designers and Manufacturers of Microphones and Acoustic Devices



of each chapter there are numerous review exercises, both questions and problems. Demonstrations described in the text may be performed with parts from a discarded radio receiver and the equipment available in the science room. The understanding of alternating current phenomena has been simplified by weaving the essential mathematics into the discussion at the time when it proves most useful—during the study of alternating currents.

This book has been treated from a practical viewpoint, in that it urges pupils to undertake the dismantling of discarded receivers. The author is to be commended for his treatment.

**Spot Radio News**

(Continued from page 14)

And his British patent is even more startling, for his drawings show a *horseless carriage* with a radio set that he termed a *raidio*. Unfortunately, Mr. Stubblefield refused all offers to develop his system, and in 1928 he died unknown and practically destitute.

**DURING THE EARLY PART OF FEBRUARY** when the terms *victory model*, *utility model* and *simplified model* were running wild in Washington, a standard terminology, *war model*, was adopted. This term was to have been used to describe commodities which met the requirements of specifications in production and price regulations issued by government war agencies. However, during the ensuing months the hopes of possible production of war models seemed to diminish and the term *victory parts* or *standardized parts* returned once again. There is now talk of the return of a new type of model known as *postwar model*. This time Washington promises that the term will really be used. Well, we'll see.

**THE STRICT AND SEVERE L265** has been amended in a manner favorable to the industry. No longer, for instance, is it necessary to have special WPB authorization to remove the radio from an automobile or to sell that removed radio. The recent amendment also provides for the removal of the restriction covering sale of automobile radios and automatic phonographs to the consumer, provided, of course, that such equipment was completed on or before April 24th of this year. An additional concession made by the amendment is permission to sell antenna, antenna couplers, power supplies and battery cables for battery type home radios, automobile radio control assemblies, loud speakers and cables. Heretofore, all this equipment was not available for sale or transfer.

**IT'S A CASE OF BAD DISTRIBUTION IN LONDON, TOO.** A recent survey shows that a shortage of electrolytic condensers and tubes has been

**PORTABLE  
CHANGER-RECORDER**



**DELUXE MODEL** automatically plays 10" or 12" records. Crystal pick-up, magnetic cutting arm, manual and reject control. Sturdily built plywood cabinet, simulated leather covering.

- No. 405 Cabinet only (uncut panel) ..... **\$9.95**
- No. 280 Changer-Recorder only ..... **\$49.95**
- No. 475 Complete Unit ..... **\$54.50**

**SPEAKERS**

1942 Fourteen inch concert grand electro-dynamic speakers. 900 ohm field, 6-8 ohm voice coil, 15 watts output. Excellent quality. Regular list price \$13.20 each.



- No. 14D single units ..... each **\$4.95**
- Lots of four ..... each **\$4.00**

**RECORDING ARMS**



- No. BR27 DeLuxe Record cutting arm assembly, complete with Astatic cartridge. Single unit price ..... **\$9.95**

Write Today for Bargain Bulletin  
**MUTUAL RADIO PRODUCTS CO.**  
 2926 Shakespeare Ave.  
 Chicago, Illinois

**Short-Cut Mathematics**  
 COMBINED WITH  
**Practical Mechanics Simplified**

NEW 2-in-1 reading course! Now you can learn the speedy, simplified system of calculation used by draftsmen, engineers, accountants. "master minds" on the stage. Learn easy way to multiply 4 figures by 4 figures without using old-fashioned multiplication; add long columns of figures this lightning short-cut method. Learn horsepower, slide rule, micrometer, logarithms, wood measure, puzzles, etc., etc. Large illustrated volume complete with answers, only \$1 postpaid. Satisfaction or refund. Amaze your friends with your magic-like mental powers

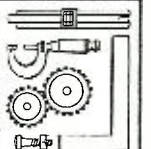

**FREE** Complete details...mail coupon TODAY!

**NELSON CO., 321 S. Wabash, Dept. 309-H, Chicago**  
 Please send free details about "Short-Cut Mathematics and Practical Mechanics Simplified." No obligation.

Name .....  
 Address .....

# LEARN CODE

the way you'll be using it

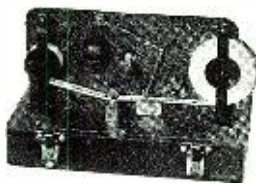

by SOUND

The best way to learn to read code is by listening to code. The best way to learn to send code is by hearing your own sending repeated back to you. With the new All-Electric Master Teleplex Code Teaching Machine, you learn code the natural, easy, fascinating way. Only instrument ever produced which records your sending in visible dots and dashes—then SENDS BACK your own key work at any speed you desire. There are NO PERFORATIONS—NO INK. Far superior to anything ever developed... a marvel of simplicity. That's why practically every school teaching code uses MASTER TELEPLEX. We furnish complete course, including the All-Electric Master Teleplex, give you personal instruction with a MONEY-BACK GUARANTEE—All at a surprisingly low cost. Write today for FREE catalog RN-6. No obligation.

TELEPLEX CO., 107 HUDSON ST. JERSEY CITY, N. J.

## MASTER DRAFTING MACHINE

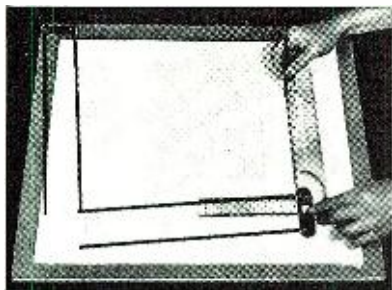

• Biggest time-saver for dimensioned sketches, lettering and layouts ever sold at this low price. Size, 20" x 24". Limited supply. While they last only \$3.95

Order Today!

**RANDOLPH RADIO**

609 W. RANDOLPH ST., CHICAGO 6, ILLINOIS

## RADIO AND ELECTRONIC DEVICES



**BURSTEIN-APPLEBEE CO.**

1012-14 McGee St. Kansas City, Mo.

## COMMERCIAL RADIO INSTITUTE

A radio training center for twenty-three years. Resident Courses only.

Pre-Induction, Broadcast, Service and Radio Telegraphy classes now forming for August 9th. Literature upon request.

Dept. D, 38 W. Biddle St., Baltimore-1, Md.

caused by maldistribution. For some reason or other quantities of this merchandise were being directed to unauthorized sources. The Board of Trade is making every effort to correct this evil. American methods of control are being studied.

**RADIO BECAME A TRUE MESSENGER** of mercy when it served as a vital beacon to a group of damaged Allied planes during the crucial and final phases of the campaign in North Africa. A portable radio station located on a mountain range in Tunisia directed many pilots during this historical period. Eight men who operated the station were isolated at the mountainous retreat for weeks. However, they stayed at their posts and saw to it that these vital messages were transmitted and received by the Allied planes.

**FREQUENCY MODULATION** which has been gaining many friends in England, was recently the subject of a very interesting analysis by Dr. K. R. Sturley of London. In a fifty-eight page presentation he presents a most thorough analysis on the subject. While many of the pages are devoted to an engineering treatment, there are many appropriate chapters that the laymen can understand. Dr. Sturley discusses many of the perplexing peculiarities of the general nature of the system in a most lucid way.

Although the book has been published in London and distributed there, your correspondent has been told that it may be available soon in America. We hope so.

**THE FEDERAL MANUFACTURING AND ENGINEERING CORPORATION** has been notified by Under-secretary of War Robert P. Patterson, that they have been awarded for the second time the Army-Navy Production award for meritorious service on the production front. This second award is symbolized by the white star which now takes its place on the "E" flag which was received six months ago.

The Federal facilities now comprise three plants with more than 500 employees. The Federal Manufacturing and Engineering Corporation has been in business 21 years, and for the past 15 years have been suppliers for the War Department of radio communications equipment. David H. Engelson, President, Jesse C. Fishel, Treasurer, have both been with the company since its inception. M. Kaporowitz, Chief Engineer, has been connected with the organization for 15 years, making a total of 57 years of constant activity for these three executives.

### PERSONALS . . .

When Commander **PIERRE BUCHERON**, USNR, met one of the members of the radio industry, also in the Navy, during actual duty, the Commander had difficulty in identifying himself. Seems as if the Commander had so heavy a growth of

For VICTORY Buy  
United States War  
Bonds and Stamps

# POLYMET

## CONDENSER CO.

699 EAST 135th ST.  
NEW YORK, N. Y.

**CONTINUOUS  
DEPENDABLE  
SERVICE**

**FOR  
JOBBER &  
DISTRIBUTORS**

## FIX ANY RADIO

Amazing New Invention

Simplified  
Radio  
Servicing  
by  
Comparison  
Method

Learn to repair radios in minutes instead of hours. Revolutionary, different **Comparison** technique permits you to do expert work almost immediately. Most repairs can be made without test equipment or with only volt-ohmmeter. Simple point-to-point, cross reference, circuit suggestions locate faults quickly and easily.

**FOR BEGINNERS OR EXPERTS**

Find any radio fault with ease. Follow the comparison tests given on 16 large trouble-shooting blueprints. 112 fact pages. Over 1,000 practical repair hints. Hundreds of simplified tests using a 5c resistor and a filter condenser. Covers every radio set—new and old. Introductory material for beginners and to serve as a review for experienced radio men. Also several chapters on test equipment. Presented in manual form, 8½ x 11 inches. Entire plan is stark new and will change servicing methods. Used in schools, Armed Forces, and by thousands of radiomen.

### SATISFACTION GUARANTEED

Take advantage of our "no-risk" trial. Send coupon today. Use this time-saving, money-making radio servicing method for 10 days without any obligations. See how much time you will save every day on every radio job. Learn new short-cuts in radio servicing. Then decide to keep **Comparison Method Manual** or return it and receive a cash refund. You cannot lose—but you owe yourself a chance to look at this plan. Price, complete, only \$1.50.

### NEW 1943 EDITION

The training will more than pay for itself on the first radio job. Examine and use this unique plan for 10 days at our risk. Send coupon right now—use the plan this week.



Developed by M. N. Beitman, radio engineer, teacher, author, & serviceman.

### TRIAL ORDER COUPON

**SUPREME PUBLICATIONS**, 328 Jefferson St., Chicago, Ill.  
Ship the new manual, **Simplified Radio Servicing by Comparison Method**, for examination. I am enclosing \$1.50, full price, send, postpaid. I must be satisfied or you will refund my money.

NAME:.....

ADDRESS:.....



*Specialists  
in all Types*

**RADIO  
WIRE and  
CABLE**

with  
"Plasite" Insulation



**WHITNEY BLAKE CO.**  
NEW HAVEN, CONN.

*Distributed by Graybar*

**GENERAL INDUSTRIES  
SMALL-POWER MOTORS**

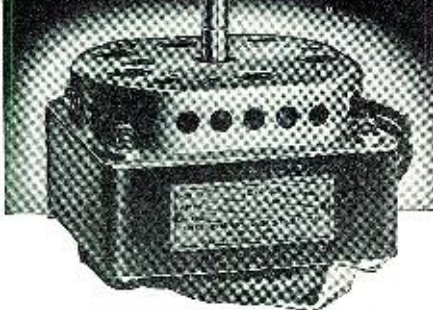

### Fit into the War Program

The G. I. plant is producing small-power motors entirely for war needs. Made of quality materials, precision-machined, they assure quiet, smooth-running and reliable performance of any device into which they are built. G. I. is also building electronic and other precision-made devices for the war effort. The assistance of G. I. engineers is available to manufacturers producing on Government orders. Let us discuss your problem with you.

**THE GENERAL INDUSTRIES CO.**

ELYRIA OHIO



whiskers, that he was effectively disguised. And when a photograph of the Commander with this beard was shown around the Farnsworth plant, where he was General Sales Manager before the war, it also took several moments before recognition came to the fore. The Commander, who was visiting Farnsworth, is back on Naval Duty again. . . . At the recent RMA Conference in Chicago, **PAUL V. GALVIN** was reelected president. **R. C. COSGROVE** was elected chairman of the Set Division. **M. F. BALCOM** was reelected chairman of the Tube Division and **RAY E. SPARROW** was reelected chairman of the Parts Division. **THOMAS A. WHITE** was elected to the post of Amplifier and Sound Equipment Division chairman. Many Government officials were present at this conference. Among these were, **JAMES L. FLY**, chairman of the FCC; **RAY C. ELLIS**, director WPB Radio and Radar Division; **BRIG. GENERAL JOHN H. GARDNER**, Signal Corps, Wright Field; **REAR ADMIRAL A. M. CHARLTON**, Navy Department, Chicago; **CAPTAIN C. A. RUMBLE**, Navy Department, Washington; **F. D. TELLWRIGHT**, director ANEPA and **FRANK H. MCINTOSH**, WPB Radio and Radar Division. . . . **JOHN S. HABER**, vice-president of Philco International, died recently, while on a trip to Cuba. . . . **RAYMOND G. ZENDER** of Lens Wire has been appointed a consultant on the insulated wire and cable section of the WPB Radio and Radar Division. . . . **SERGEANT BARNEY ROSS** recently visited Chicago and dropped in to speak to the workers of Shure Brothers about the importance of microphones on the battlefield. . . . **WILLIAM B. LEWIS**, formerly with the Columbia Broadcasting System, who joined the government services in the early fall of 1941, has left Washington. No future plans have been announced. . . . **WILLIAM S. PALEY**, president of the Columbia Broadcasting System, and **EDMOND A. CHESTER**, director of short wave broadcasting of CBS, were recently awarded the highest civilian decoration of the Cuban government, The Carlos Manuel de Cespedes National Order of Merit, for their achievements in furthering continental solidarity through the creation and operation of the 97 station-chain linking all of the twenty Latin American republics. . . . The noted communications inventor **GEORGE WASHINGTON PIERCE** has been awarded the Franklin Medal of the Franklin Institute in Philadelphia, Pennsylvania. Professor Pierce is known for his famous oscillator circuit, which is used so effectively in many transmitters. Professor Pierce also developed the mercury vapor detector and amplifier, the equivalent to the Thyatron which was developed by General Electric later on. . . . **JOHN K. HILLIARD** who was formerly chief transmission engineer of MGM sound division, and more recently a consultant at the Radiation Labora-

tories of M.I.T., is now chief engineer of the Radar and Motion Picture Division of Altec-Lansing Corporation of Los Angeles, California.

-30-

### Air Raid Alarm Circuits

*(Continued from page 25)*

to be sure that the audio voltage is impressed between the starter anode and cathode of the first tube, since the cathode is above ground and incorrect connections would affect the amount of voltage on the tube. Incidentally, the plate voltage of the last audio tube in the receiver should not be more than 225, since this is the breakdown voltage of the OA4G. Since the tube replaces the cathode resistor of the last stage, a cathode condenser should not be used in this stage.

Using the values of 1/2 megohm and 1 µfd. in the series-bridging circuit, the tone will be heard after five seconds of tone, and the static interrupting time. These values can be changed to provide any desired operating time delay action.

The receiver used with this system should have a good avc, particularly if a weak signal is to be monitored.

The 50,000-ohm resistors are the current limiting resistors for the two trigger tubes. Starter anode currents should be a maximum of 200 microamperes for both tubes.

A very unique alarm system is in operation in a broadcasting station in Indiana. Developed by Victor H. Voss, chief engineer of WIND, the circuit (Fig. 5) is designed to operate on a warning tone of 20 to 30 seconds duration. And almost any superheterodyne type of receiver can be used with his system. In this system, a signal from the last i-f stage is fed to one diode section of a 6H6, functioning as a second detector. The audio output of the detector is fed to a 6C5, which is used as a voltage amplifier. This amplifier drives another 6C5 filter tube. Then the output of the filter tube is fed into the primary of a transformer. The voltage developed across the transformer secondary is rectified by the other section of the 6H6. The output of the second diode section of the 6H6 is then fed into a relay circuit and travels across a load resistor. This resistor is in series with the grid circuit of the 6C5 relay control tube. The 22.5 v. battery provides sufficient negative voltage to cut off the anode current of the 6C5 relay control tube in the absence of an incoming carrier. The alarm operates if the carrier is cut off. However, in the presence of a carrier, a voltage is developed across the diode detector load. This partially balances out the bias battery, allowing sufficient current to flow in the control tube to close the relay. Thus the alarm circuit then becomes available for the alarm tone. Upon receiving the warning tone, a voltage is developed across the load resistance in the relay circuit of the second 6H6

## TUBE TROUBLES?

Check them with the handy guidebook that features . . . . .

- ★ Complete coverage of popular tube types
- ★ Full information on socket changes
- ★ Over 100 different substitutions and change-overs
- ★ 5 substitutes for 50L6GT

20 pages of non-technical comprehensive data contained in the . . . . .

### RADIO TUBE SUBSTITUTION AND CHANGE-OVER MANUAL

By Robert T. Oelrich

Order your copy now! Price: \$1.00, postpaid

#### OELRICH PUBLICATIONS

1627 S. Keeler Avenue, Chicago, Illinois

## RADIO TECHNOLOGY



RCA Institute offers an intensive two-year course of high standard embracing all phases of Radio and Television. Practical training with modern equipment. Also shorter specialized courses in Commercial Radio Operating, Radio and Television Servicing, and Aviation Communications. For Free Catalog write Dept. RN-43.

### RCA INSTITUTES, Inc.

A Radio Corporation of America Service  
75 Varick St., New York

## RADIO ENGINEERING DEGREE IN 27 MONTHS

Intensive, specialized course, including strong basis in mathematics and electrical engineering. Advanced Radio Theory and Design. Modern laboratory. Low tuition. Self-help opportunities. Also 27-month courses in Aeronautical, Chemical, Civil, Electrical and Mechanical Engineering. Participation in Civilian Pilot Training Program. Enter Sept. 1, Dec., Mar. & June. Catalog.

### INDIANA TECHNICAL COLLEGE

783 E. Washington Blvd., Fort Wayne 2, Ind.

## VICTORY LINE

These products always stand at the head of the line. We're lucky to have them—you're lucky to get them. Aerovox Condensers, Ken-Rad Tubes, Mueller Clips, Duotone Recording Blanks, Pickup Needle screws. Send deposit with tube orders.

ANCHOR RADIO DISTRIBUTING SERVICE CO.  
ITHACA BOX 21 NEW YORK

## GOOD JOBS in RADIO For Both Men and Women

Prepare now for jobs in Radio Engineering; Broadcasting; Marine, Aviation, Police Radio; Servicing; Radio Manufacturing. Our streamlined courses give excellent preparation for Army and Navy Service. Expenses low. Write for free catalog.

THE DODGE TELEGRAPH & RADIO INSTITUTE  
409 Monroe St., Valparaiso, Indiana

## Correspondence Courses in RADIO and ELECTRICAL ENGINEERING

**ELECTRICAL ENGINEERING** Get good electrical field. Prepare yourself at Low Cost, for secure future. Modern course. So simplified anyone can understand quickly.  
**RADIO ENGINEERING** Extra fine course in radio, public address, photo-electric work. Trains you to be super-service man, real vacuum-tube technician. Servicemen needed badly. Diploma on completion.

Send postcard or letter for Free Catalogs of school catalog, full details, all about deferred payment plan, etc. SEND NOW!  
**LOW \$25 Either AS Course**  
LINCOLN ENGINEERING SCHOOL, Franklin Stn., Box 61-R 56 (Formerly at Lincoln Neb.) WASHINGTON, D. C.

COMING IN THE SEPTEMBER ISSUE  
Electronics in Crime Detection and Prevention  
(The modern role of electronics as a Scientific Sleuth)

section. This voltage balances out the carrier voltage developed across the detector diode load resistor allowing the bias battery to cut off the plate current of the control tube and consequently opens the relay and produces an alarm. This alarm is a bell, which rings, until the operator throws a switch, which removes it from the circuit and connects a monitor speaker over which announcements may be heard. Depression of a reset button when the alarm period is over, restores the system to its original stand-by condition.

Incidentally this unit is so designed that a warning is provided not only when the required warning tone is received, but also in the event that the monitored station carrier, the unit itself or the associated receiver fails.

The relay used has a d.c. resistance of 5000 ohms. It opens at 6 ma. and closes at 12 ma. If one of lower resistance must be used, a series resistor must be added.

In making the initial adjustments of the receiver, the r.f. gain should be adjusted to give a value of 15 ma. in the plate circuit of the 6C5 control tube.

All of the systems described have gone through an intensive series of tests and have proven themselves extremely reliable. We hope that they will never have to be used for other than tests. But if the critical emergency does arise, they will be ready to serve and serve well.

-50-

## Wide Band Amplifier

(Continued from page 22)

that  $R_1 C_1$  equal  $C_2 R_2$ . Knowing all these values but  $C_2$  we can calculate its capacity.

$$R_1 C_1 = C_2 R_2$$

$$980 \cdot 6.37 = 500,000 C_2$$

$$C_2 = \frac{5800}{500,000} = .0116 \mu\text{fd.}$$

The capacity of the coupling condenser should be .0116  $\mu\text{fd}$ .

In practice it is wise to have the reactance of the screen by-pass condenser at the lowest frequency desired equal to one-tenth or less of the value of the screen voltage dropping resistor.

Having made the low frequency compensation, we can now expect that it will faithfully amplify square waves (the criterion in judging the quality of amplifiers) with fundamental frequencies as low as 50 cycles per second.

If the low frequency compensation is not carefully calculated, the amplifier may be either over or under compensated as shown in Fig. 9.

Having been compensated for both high and low frequency loss, the amplifier will now have a nearly uniform response extending from 50 cycles to 5 megacycles. The amplification at the two limits being .707 of the amplification at the intermediate frequencies.

-50-

# 7 DAYS

## Free Examination

# PRACTICAL RADIO INFORMATION

Including Frequency Modulation—Television, etc.



Inside Radio Information for all Servicemen—Aircraft Pilots, Students. AUDELS RADIO MANS GUIDE contains 772 Pages, 400 Diagrams & Photos is complete—gives Authentic Principles & Practices in Construction, Operation, Service & Repairs. Covers clearly and concisely Radio fundamentals—Ohm's Law—Physics of sound as related to radio science—Measuring instruments—Power supply—Resistors—Inductors—Condensers—Transformers and examples—Broadcasting stations—Radio Telephony—Receivers—Diagrams—Construction—Control systems—Loud speakers—Antenna systems—Auto Radio—Phonograph pickups—Public Address Systems—Aircraft & Marine Radio—Radio Combs—Beacons—Automatic Radio Alarms—Short Wave—Coil Calculations—Testing—Cathode ray oscillographs—Static Elimination—Trouble Pointers—Underwriter's standards—Units and tables—Frequency Modulation—REVIEW QUESTIONS & ANSWERS. Ready Reference Index.

**\$4 COMPLETE • PAY ONLY \$1 A MO.** Get this practical information in handy form for yourself—Fill in and MAIL COUPON TODAY—

AUDEL, Publishers, 49 W. 23rd St., N.Y. Mail AUDEL'S NEW RADIO MANS GUIDE for free examination. If O.K., I will send you \$1 in 7 days then rent \$1 monthly until \$4 is paid. Otherwise I will return it.

Name \_\_\_\_\_  
Address \_\_\_\_\_  
Occupation \_\_\_\_\_  
Reference \_\_\_\_\_ RN

## RADIO PARTS SOUND SYSTEMS ELECTRONIC APPARATUS

# Depend on RADOLEK

### Send Now for the Big RADOLEK Buying Guide!

Make Radolek your dependable source for essential radio, sound and electronic replacement parts—tubes, condensers, volume controls, resistors, transformers, etc.—all at lowest prices. Orders for industry, Government services and war training programs are given special attention. Thousands rely on Radolek for their entire requirements. Send for the big Radolek Buying Guide NOW!

**FREE! Lowest Prices Fast Service**  
Radolek quality, low prices and prompt service save valuable time and money. For complete satisfaction send your orders to Radolek.

**SEND TODAY!** PARTS ON A PLAT CARD

RADOLEK CO., Dept. B-81  
601 W. Randolph St., Chicago, Ill.  
Please send the Big FREE Buying Guide

Name \_\_\_\_\_  
Address \_\_\_\_\_  
 DEALER  SERVICEMAN  SOUND ENG.

## SAVE AT RADOLEK

# ★ INDUSTRIAL ★ MAN-POWER BUREAU

## FORWARD-LOOKING COMPANY NEEDS ENGINEERS

Progressive company with expanding engineering department seeking several good men not now employed at highest skills in war industry.

One with good theoretical knowledge of acoustics, experience with magnetic circuits and acoustical measurements.

Another for laboratory measurements on a-f communications apparatus. To design and supervise equipment for production testing, maintaining laboratory standards. Should be familiar with government specifications and inspection procedure.

Another familiar with application and molding techniques of plastics. Should have several years' design experience on small electrical apparatus, understanding of magnetic and electrical circuits.

Will be concerned now with war contracts and planning postwar developments in technically expert organization that's going places. Write, phone or wire background and salary requirements to Chief Engineer.

**GREAT AMERICAN INDUSTRIES, INC.**  
70 Britannia St., Meriden, Conn.

## CHANGE TO WAR WORK

A promising future is assured if you can demonstrate real ability.

**DRAFTSMEN**—Small mechanical products  
**ELECTRONICS**—ENGINEERS

Those now employed in War Work need not write.

Box No. 314.

c/o Radio News,  
270 Madison, New York 16, N. Y.

## Wanted as Laboratory Aides

Practical radiomen and women with sufficient radio background to enable us to train you WITH PAY for good-paying positions on our faculty staff. For lecture and laboratory work in new school training men for U. S. Signal Corps. Must be draft exempt. Excellent salaries and working conditions. Ample living accommodations. Write complete background and experience. Prompt interviews to nearby applicants.

**CAPITOL RADIO ENGINEERING INSTITUTE,**  
Dept. G, 3224 16th St., N. W., Wash. 10, D. C.

## CAN YOU FILL ONE OF THESE MOST IMPORTANT WAR JOBS?

If you have a college education (not necessarily a graduate) and know theory and practice, you are urgently needed by a non-profit, non-commercial organization assigned to vital war research.

- **Electronic Engineers**
- **Radio Engineers**
- **Electrical Engineers**
- **Physicists**
- **Mechanical Engineers**
- **Electrical Designers**
- **Electronic Designers**
- **Acoustical Specialists**
- **Communication Engineers**
- **Geophysicists**
- **Seismograph Technicians**

*If you are in one of the above categories and your highest skill is not being utilized to help save lives and materials, to help shorten the war, please write! ACT NOW!*

Salaries range from \$3,000 to \$8,000, depending upon experience, ability, education and past earnings. In addition, we will pay all expenses of transportation, moving, etc., for you and your family. You must be free to travel. Living quarters will be made available. If granted an interview, we will compensate you for all expenses incurred in coming to New London. Don't wait! Write, stating background and experience to . . .

### PERSONNEL DEPT.

P. O. Box 271, New London, Conn.

## ELECTRONICS

Engineers  
Laboratory Assistants  
Production Men

### Well Paying War Job Plus Peace Time Career!

Ideal working conditions with expanding manufacturers now at war work and planning peace time development. Unlimited opportunity for an important place in a New World of Radio.

Men employed at full skill  
in war industry should not  
apply!

All others write Today!

**PANORAMIC RADIO CORP.**  
242 West 55th Street New York  
New York New York

Draftsmen, Electrical Testers, and Electrical Inspectors wanted by reliable company making motors and generators. Guaranteed steady work, good pay, 48 hours per week. Box 315, c/o RADIO NEWS, 540 N. Michigan Ave., Chicago.

## ELECTRONICS Engineers and Technicians

Radio Engineer or Physicist to manage development group. Knowledge and experience in design of electrical measuring equipment, particularly in ultra-high-frequency field, essential. Permanent position. Write full particulars.

ALSO

Openings for Electronics Engineers, Technicians, Testers, Inspectors, and Radio Repairmen With Suitable Qualifications.

100% War Work

War Workers Employed at Highest  
Skill Need Not Apply.

Box 390—Boonton, New Jersey

## JOBS IN CHICAGO!

# RADIO

TESTERS  
REPAIRMEN  
TEST EQUIPMENT

Also **RADIONICS ENGINEERS**

WRITE US GIVING—

Experience • Salary • Draft Status • Etc.

**ZENITH** 8001 W. DICKENS  
CHICAGO-39  
ILLINOIS

## ELECTRICAL ENGINEER

Graduate, student or practical. For work in condenser laboratory. Salary commensurate with ability. Draft deferred.

**MICAMOLD RADIO CORP.**

1087 Flushing Ave.

Brooklyn, N. Y.

## Technical Writers Wanted

Box 520 c/o Radio News

540 N. Michigan Ave.

Chicago 11, Ill.

This section is designed to help the radio industry obtain trained, experienced, technical men to facilitate vital war production.

## ELECTRONIC ENGINEER

**Wanted at Once!** A client of ours—one of the most progressive and alert manufacturers in the electronic field, has an immediate need for a thoroughly trained and experienced engineer. This Company has been well established for more than 10 years, and is currently engaged in war work, but has already outlined a definite program for post-war production.

This position is permanent, and offers unlimited opportunity to a man with ability, vision and a desire to make real progress. Located in a medium size midwest city, with pleasant living conditions. Preference will be given a graduate engineer with a proven record—but not essential. *Write Today*, stating age, draft classification, family status, training, experience, present salary and other pertinent information.

**W. D. LYON CO.**  
Bever Bldg., Cedar Rapids, Iowa.  
Att.: Mr. Evans.

★ ★ ★ ★ ★ ★ ★ ★ ★ ★

**RADIO CALLING**

**100% WAR WORK**

AND

**POST-WAR OPPORTUNITIES**

Men with experience in high frequency circuits on transmitters and receivers, for the following work:

★ Factory Technicians	★ Development Engineers
★ R.F. Coil Engineers	★ Process Engineers
	★ Production Engineers

★ Married men with children or otherwise draft deferred given preference.

★ **THE HALLICRAFTERS CO.** ★

★ 2611 S. Indiana Avenue, Chicago, Illinois ★

★ ★ ★ ★ ★ ★ ★ ★ ★ ★

## HELP WANTED

**ELECTRONIC ENGINEERS,**  
Mechanical Engineers  
with

Knowledge of Electronics,  
Licensed Radio Operators  
to work with a

Modern Television Concern  
Presently devoting 100% of its  
efforts to National Defense

**Allen B. Du Mont Laboratories, Inc.**  
2 Main Ave., Passaic, N. J.

## —RADIO AMATEURS—

**Attention!**

## WESTERN ELECTRIC CO.

*"The Arsenal of  
Communications Equipment"*

Offers Positions For:

## ELECTRICAL TESTERS

For Radio Transmitters and Receivers. Men who have been licensed radio amateurs preferred, or those having a good technical knowledge of voice communication and trained in electrical testing of radio equipment are needed for inspectors and testers.

Those presently engaged in essential industry will not be considered.

Write (or apply) stating  
experience and education.

C.A.J., Dept. 811

100 Central Ave., Kearny, N. J.

or

G.P.H.

395 Hudson St., New York, N.Y.

**Western Electric Co.**

## TECHNICIANS WANTED

We are the country's largest makers of X-Ray Tubes, and have openings in our Tube Exhausting and Electrical Testing departments for several persons with knowledge of physics and electrical theory. Openings also in Machine Shop and Inspection Department.

**MACHLETT LABORATORIES, Inc.**  
Springdale (near Stamford), Conn.

## TECHNICAL WRITERS WANTED!

Engineers and physicists who have had experience in (spare time) writing technical manuscripts on electronic design or applications including radio, television, facsimile, etc. Highest rates.

Reply Box 310, c/o RADIO NEWS  
540 N. Michigan Ave., Chicago

## TECHNICIAN

FASTEST GROWING RADIO PUBLICATION HAS PERMANENT POSITION FOR WELL-EDUCATED ENGINEER WITH KNOWLEDGE OF ELECTRONICS AND PHYSICS

Send full qualifications to

Box 310, c/o RADIO NEWS  
540 N. Michigan Ave., Chicago, Ill.

## Letters to the Editor

on the

## SPECIAL AVIATION COMMUNICATIONS

Issue of RADIO NEWS

THE June Aviation Communications issue of RADIO NEWS met with wide acceptance—not only from our regular readers—but by the military personnel of our various branches of service. It is most gratifying that we have been able to contribute to the war effort by publishing factual information on the part that radio is playing, both on the fighting, as well as the home fronts. Hundreds of letters have been pouring in—commenting favorably on the June issue. A few of them appear below: We wish to express our deep appreciation to those who have sent letters and comments on our undertaking.

"... You have done another commendable piece of work in presenting such a comprehensive résumé of outstanding achievements in the field of Aviation Radio. This is a comparatively little known field which constitutes a very vital part of the vast communications system so essential to the success of our military mission. This edition, as a reference book on the subject, is indeed a direct contribution to the general knowledge of a most important subject."

DAWSON OLMSTEAD  
Major General  
Chief Signal Officer of the Army

"... I have noted the information contained therein with a great deal of interest and think you are doing a swell job. . . ."

BREHON SOMERVELL  
Lieutenant General Commanding  
Army Service Forces

"... It is one of the best I have ever seen up to date.

As one radio man to another, and as one who is tremendously interested in the communication features in aviation, I feel that you have made a tremendous contribution to our war effort and, also, for future aviation. . . ."

KARL STEFAN  
Congressman, 3rd Dist. Nebraska

"... This issue is a fine piece of work and gives the authoritative story on the part communications are playing in the tremendous military undertaking now before us. You are to be congratulated on the publishing of a very beautiful and informative piece of work."

W. H. S. WRIGHT  
Lt. Colonel, Cavalry  
Aide to the Secretary of War

"... This appears to be a comprehensive picture of this important phase of the war job. I shall circulate it among my associates who are particularly interested in the activities covered."

C. H. LANG  
General Electric Co.

"... It is particularly interesting to those of us who are engaged in helping the production of this equipment and we have found it of great benefit."

E. T. HERBIG, JR.  
Capt., Sig. C  
Officer in Charge  
Army-Navy Electronics  
Production Agency

"... I was really amazed at the completeness of the issue and found its contents highly interesting, particularly those referring to the Technical Training Command's schools.

I sent it around to the chief of staff and all the staff sections in these headquarters and hear much favorable comment. I believe it a worthwhile contribution indeed.

G. R. JOHNSTON  
Lt. Col., AC  
Public Relations Officer



Send for this FREE 52-page Book

It shows that "crack" operators rely on something besides practice to develop their high speeds and proficiency; it explains the "knack" of sound-sense and sound-consciousness—the secret of speedy sending and receiving. Once you acquire these mental processes, reading code becomes almost second nature to you; just as the swing rhythm of a dance band becomes automatic to musician and dancer.

Champions endorse the Candler System. Used in training commercial operators, Amateurs, and Radiotelegraph Specialists in Signal Corps, Navy, Marine Corps, Coast Guard, Naval Reserve, Airlines. Wherever the fastest and most efficient operators are found, there you will find Candler trained men.

If you want speed, if you have any difficulties in operating technique, if 40-50 and more w.p.m. seem fantastic speeds to you—send for this revealing book now. It's yours without cost or obligation. Simply send your name and address.

**CANDLER SYSTEM CO.**

P. O. Box 928 Dept. 2-J  
Denver, Colorado, U. S. A.

Craven House, 121, Kingsway, London, W. C. 2

**NOW—A REALLY HIGH-POWERED—  
Radio Engineering  
Library**

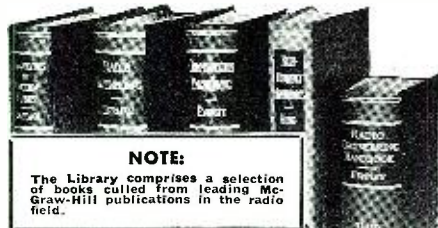

**NOTE:**

The Library comprises a selection of books culled from leading McGraw-Hill publications in the radio field.

- especially selected by radio specialists of McGraw-Hill publications
- to give most complete, dependable coverage of facts needed by all whose fields are grounded on radio fundamentals
- available at a special price and terms

THESE books cover circuit phenomena, tube theory, networks, measurements, and other subjects—give specialized treatments of all fields of practical design and application. They are books of recognized position in the literature—books you will refer to and be referred to often. If you are a practical designer, researcher or engineer in any field based on radio, you want these books for the help they give in hundreds of problems throughout the whole field of radio engineering.

**5 VOLUMES, 3319 PAGES, 2289 ILLUSTRATIONS**

1. Eastman's FUNDAMENTALS OF VACUUM TUBES
2. Terman's RADIO ENGINEERING
3. Everitt's COMMUNICATION ENGINEERING
4. Hund's HIGH FREQUENCY MEASUREMENTS
5. Henney's RADIO ENGINEERING HANDBOOK

10 days' examination. Easy terms. Special price under this offer less than books bought separately. Add these standard works to your library now; pay small monthly installments. While you use the books.

10 DAYS' FREE EXAMINATION—SEND COUPON

McGraw-Hill Book Co., 330 W. 42nd Street, N. Y. C.

Send me Radio Engineering Library, 5 vols., for 10 days' examination on approval. In 10 days I will send \$3.00 plus few cents postage, and \$3.00 monthly till \$24.00 is paid, or return books postpaid. (We pay postage on orders accompanied by remittance of first installment.)

Name .....

Address .....

City and State .....

Position .....

Company ..... RN-8-43

**Index to Advertisers**

COMPANY	PAGE No.
Aerovox Corp.	97
Allied Radio Corp.	14
American Phenolic Corp.	Second Cover
American Radio Hardware, Inc.	5
Anchor Radio	93
Audel, Publishers	93
Barker & Williamson	85
Belmont Radio Corp.	Back Cover
Bliley Electric Co.	96
Burstein-Applebee Company	91
Candler System Co.	96
Capitol Radio Eng. Inst.	72, 94
Centralab	78
Classified	96
Commercial Radio Inst.	91
Connecticut Telephone & Electric Corp.	79
Consolidated Radio Products Co.	50
Coyne Electrical School	11
Crowe Name Plate & Mfg. Co.	51
D-X Crystal Co.	84
DeJur-Ansco Corp.	47
Dodge Institute	93
Doolittle Radio, Inc.	66
Allen B. Du Mont Laboratories, Inc.	95
Echophone	73
Eicor, Inc.	68
Electronic Corporation of Am.	55
Fada Radio & Elec. Co., Inc.	58
General Electric Company	15
General Industries Company	92
Gold Shield Products	78
Gothard Mfg. Co.	86
Great American Industries, Inc.	94
Hallcrafters Co.	56-57, 95
Hammarlund Mfg. Co., Inc.	16
Harvey Machine Co., Inc.	82
Hytron Corp.	7
Indiana Technical College	93
Insuline Corp. of America	84
International Resistance Co.	81
International Telephone & Telegraph Corp.	63
Jensen Radio Mfg. Co.	59
The James Knights Co.	9
Lafayette Radio Corp.	60
Lake Radio Sales Co.	80
Lincoln Eng. Schools	93
Machlett Laboratories, Inc.	95
Majestic Radio & Television Corp.	6
P. R. Mallory & Co., Inc.	77
McElroy Mfg. Corp.	82
McGraw-Hill Book Co.	96
Meissner Mfg. Co.	62
John Meek Industries	54
Micanold Radio Corp.	65, 94
James Millen Mfg. Co., Inc.	8
Wm. J. Murdoch Co.	48
Mutual Radio Products Co.	90
National Company, Inc.	87
National Radio Institute	3
National Schools	71
National Union Radio Corp.	67
Nelson Co.	90
Oelrich Publications	93
Ohmit Mfg. Co.	45
D. W. Ount & Sons	76
Panoramic Radio Corporation	94
Par-Metal Products Corp.	70
Pioneer Gen-E-Motor Corporation	64
Polymet Condenser Co.	91
Radio Corporation of America	52, 53
RCA Victor Division	61
RCA Institutes, Inc.	93
Radio & Tech. Publ. Co.	74
Radolek Co.	93
Randolph Radio	86, 91
John F. Rider Publ. Inc.	78
Shure Brothers	90
Solar Mfg. Co.	90
Somaron Metal Fabricators	88
Sprague Products Co.	69
Sprayberry Academy of Radio	46
Standard Transformer Corp.	80
Stevens Walden, Inc.	10
Supreme Publications	91
Sylvania Electric Products, Inc.	12
Taylor Tubes	49
Teleplex Co.	91
Thordarson Electric Mfg. Co.	76
Tobe Deutchman Corporation	98
Triplet Electrical Instrument Co.	86
Turner Co.	84
United Transformer Co.	Third Cover
Universal Microphone Co.	88
Utah Radio Products Co.	75
Ward Leonard Electric Co.	13
Western Electric Co.	95
The Whitney Blake Company	92
John Wiley & Sons, Inc.	80
Zenith Radio Corp.	94

While every precaution is taken to insure accuracy, we cannot guarantee against the possibility of an occasional change or omission in the preparation of this index.

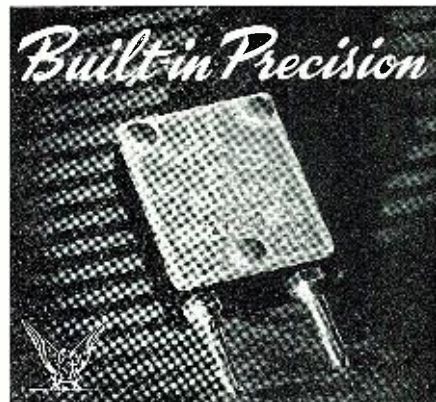

Accuracy and dependability are built into every Bliley Crystal Unit. Specify **BLILEY** for assured performance.

**BLILEY ELECTRIC CO. Erie, Pa.**

**Classified**

Rate 15c per word. Minimum, 10 words

**CORRESPONDENCE COURSES**

RADIO Communications courses qualifying for all Federal licenses. Home study and resident courses. American Radio Institute, 44 East 23rd St., New York, N. Y.

USED Correspondence Courses and Educational Books sold or rented. Inexpensive. Money-back guarantee. Write for Free Catalog listing 4000 bargains.—(Courses Bought.)—Lee Mountain, Pisgah, Ala.

CORRESPONDENCE Courses and self-instruction books, slightly used. Sold. Rented. Exchanged. All subjects. Satisfaction guaranteed. Cash paid for used courses. Complete details and 84-page illustrated bargain catalog free. Write Nelson Company, 321 S. Wabash, Dept. H-237, Chicago.

**PATENT ATTORNEYS**

PATENTS Secured. Two valuable booklets sent free. Write immediately. Victor J. Evans & Co., 748-J Merlin Bldg., Washington, D. C.

INVENTORS—Before disclosing your invention to any one send for Form "Evidence of Conception"; "Schedule of Government and Attorneys' Fees" and instructions. Sent free. Lancaster, Allwine & Rommel, 414 Bowen Building, Washington, D. C.

**RADIO ENGINEERING**

RADIO Engineering, broadcasting, aviation and police radio, servicing, marine and Morse telegraphy taught thoroughly. All expenses low. Catalog free. Dodge Institute, Elm St., Valparaiso, Ind.

**RADIO EQUIPMENT**

RADIO Service men and experimenters send for our giant radio catalogue. Save dollars. United Radio Co. (1000M), Newark, N. J.

**PHOTO CREDITS**

PAGE NUMBERS	CREDITS
17, 18, 19, 20...	U. S. Army Signal Corps
28.....	Instrument Specialties Co.
29.....	Embry Products Co. (Curves)
30 (top left), 31 (top left).....	Rural Electrification Administration
30 (top right).....	Laboratory of Experimental Embryology, Cornell University
31 (top right) 31 (bottom).....	USDA Photograph
35, 58.....	G. E.
39.....	RCA
40 (top).....	Associate Press
40 (bottom).....	World Wide Photo





# Winning

## THE WAR ... on the BATTLE FRONT and HOME FRONT alike



### OUR WAR EFFORT . . .

From January 1941 to December 1942. Aerovox

- Stepped up production output 500% for our armed forces.
- Increased production floor space 300%.
- Sought, hired, trained and put to work additional workers—a 300% increase in productive personnel.
- Opened second plant in Taunton, bringing work to available workers there.
- And—doing more and more, growing week by week.

• Our Army, Navy, Air Forces, function with clockwork precision, thanks to perfected radio coordination. Meanwhile, by spotting and ranging approaching aircraft even a hundred miles distant, regardless of weather, by night or by day, Radar eliminates another Pearl Harbor sneak attack. Lurking U-boats are losing their concealment. To cap it all, up-to-the-minute world news is available at the twist of a dial in millions of American homes whose radio sets keep functioning through proper servicing and replacement parts. We remain the best informed people. Our morale is unbeatable. Victory is in sight.

Thus a truly radio war. Radio means capacitors. Capacitors spell Aerovox. Today, working at an all-time production peak in meeting military needs and civilian replacements, Aerovox contributes its full share towards winning the war on battle and home fronts alike.

• Consult our local jobber regarding your wartime capacitor needs. Ask for latest catalog; also free subscription to the Aerovox Research Worker. Or write us direct.



# Capacitors

INDIVIDUALLY TESTED

AERVOX CORPORATION, NEW BEDFORD, MASS., U. S. A. • SALES OFFICES IN ALL PRINCIPAL CITIES  
 Export: 100 VARICK ST., N. Y. C. • Cable: 'ARLAB' • In Canada: AERVOX CANADA LTD., HAMILTON, ONT.

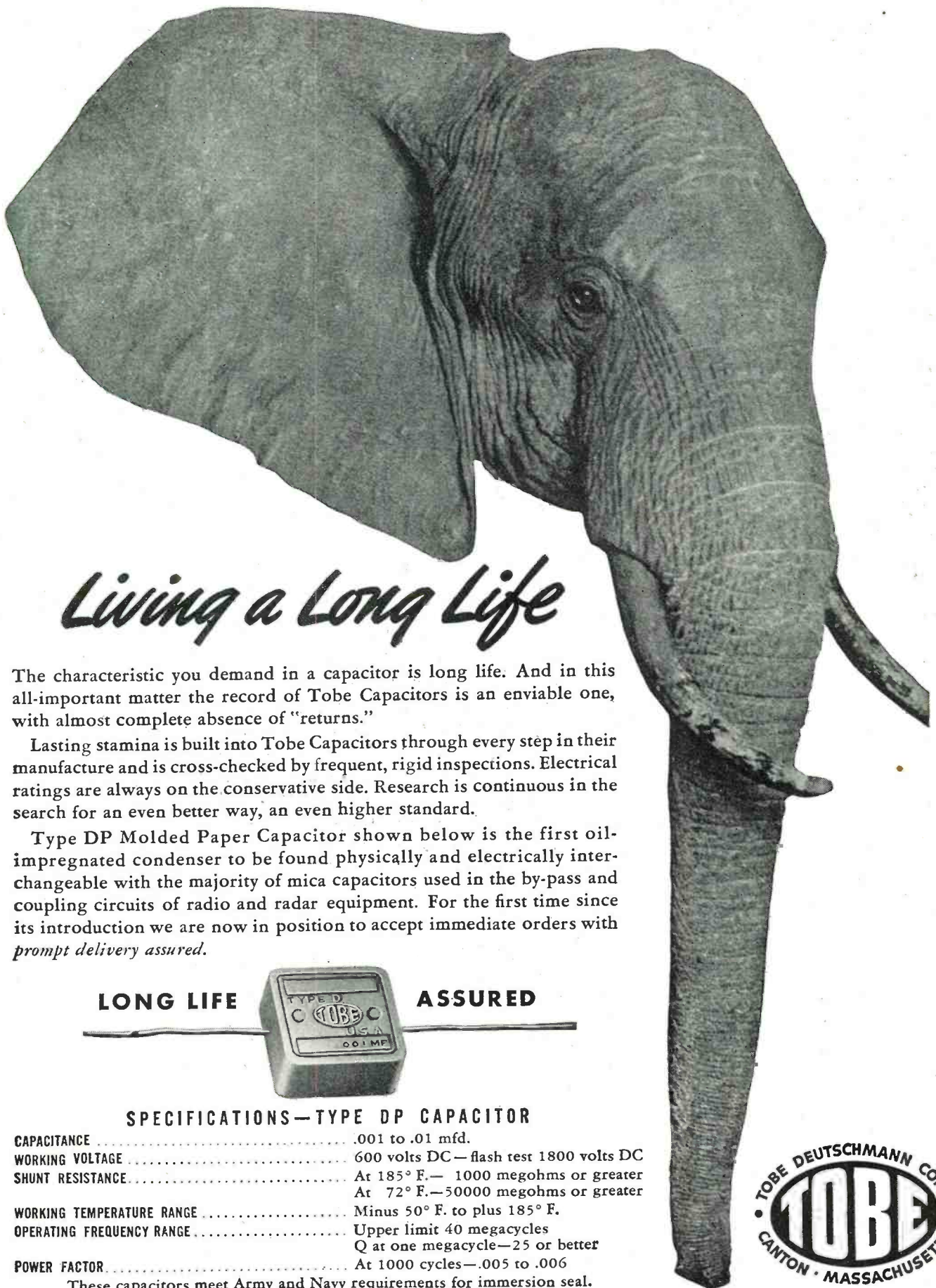

## Living a Long Life

The characteristic you demand in a capacitor is long life. And in this all-important matter the record of Tobe Capacitors is an enviable one, with almost complete absence of "returns."

Lasting stamina is built into Tobe Capacitors through every step in their manufacture and is cross-checked by frequent, rigid inspections. Electrical ratings are always on the conservative side. Research is continuous in the search for an even better way, an even higher standard.

Type DP Molded Paper Capacitor shown below is the first oil-impregnated condenser to be found physically and electrically interchangeable with the majority of mica capacitors used in the by-pass and coupling circuits of radio and radar equipment. For the first time since its introduction we are now in position to accept immediate orders with *prompt delivery assured.*

**LONG LIFE**



**ASSURED**

### SPECIFICATIONS—TYPE DP CAPACITOR

CAPACITANCE .....	.001 to .01 mfd.
WORKING VOLTAGE .....	600 volts DC—flash test 1800 volts DC
SHUNT RESISTANCE .....	At 185° F.— 1000 megohms or greater At 72° F.—50000 megohms or greater
WORKING TEMPERATURE RANGE .....	Minus 50° F. to plus 185° F.
OPERATING FREQUENCY RANGE .....	Upper limit 40 megacycles Q at one megacycle—25 or better
POWER FACTOR .....	At 1000 cycles—.005 to .006

These capacitors meet Army and Navy requirements for immersion seal.



**A SMALL PART IN VICTORY TODAY—A BIG PART IN INDUSTRY TOMORROW,**

# Designs for War... Hermetic Sealing

The hermetic sealing of transformers covers a wide range of problems, and an equally wide range of applications. The two units illustrated at the left, for example, represent a high voltage transformer for high altitude operation, and an audio unit weighing approximately one ounce.

There is more to hermetic sealing than meets the eye. The illustrations below show some of the factors contributing to the high quality of UTC hermetically sealed units.

**May we design a war unit to your application?**

*For obvious reasons, the units illustrated are not actual war items.*

## Engineering ... PRODUCT

Engineering starts with research, continues through the conference table, and then goes through the proving of electrical design, sealing methods, vibration test, etc.



**ENGINEERING CONFERENCE**



**DESIGN PROVING ... AUDIO**

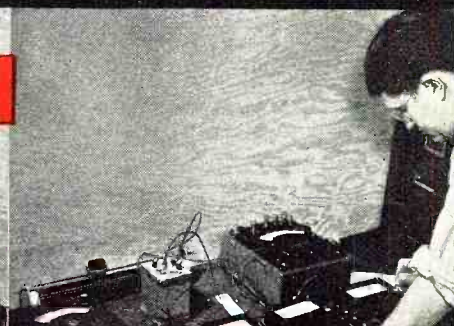

**DESIGN PROVING ... POWER**

## Engineering ... PRODUCTION

The production of war units generally requires precise control. This requires the scientific choice of workers for specific operations ... the use of modern methods throughout ... and continuous control of quality and production flow.

**APTITUDE TESTING** assures worker suited to operation

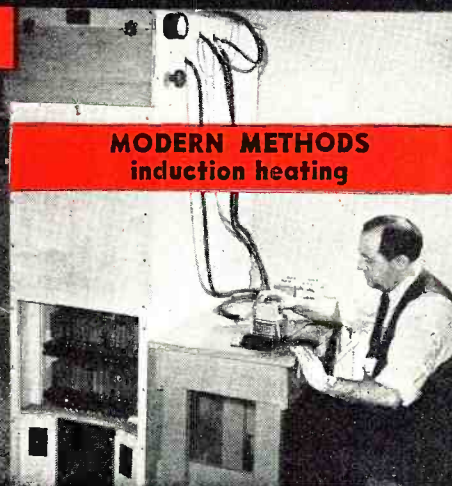

**MODERN METHODS**  
induction heating

**CONTINUOUS CONTROL** for uniformity of production



# UNITED TRANSFORMER CO.

150 VARICK STREET ★ NEW YORK, N. Y.  
EXPORT DIVISION: 100 VARICK STREET NEW YORK, N. Y. CABLES: "ARLAB"



## MARKED FOR DESTRUCTION

So sorry, please! This time, honorable sneak surprise has become dishonorable Japanese disaster! All unknown to the raiders, they were clearly seen up there in the clouds. An electronic eye followed their progress, warned of their approach, figured the range . . . marked them for destruction.

And now they're getting it! They are feeling the power of Radar in action.

The development and production of this great weapon is a Signal Corps and Navy achievement in which Belmont is proud to have played a part. And Radar is but a stepping-stone to still greater achievements!

When the war is won, Belmont will have many surprising stories to tell—stories of wartime electronic developments that will be put to new and remarkable uses in a post-war world. Belmont Radio Corporation, Chicago, Illinois.

RC-23-JB2111-14 Z4  
TECH SGT R D HONNY  
615 MAIN ST  
LAUREL MD  
H-

 **Belmont Radio**  
TELEVISION \* FM \* ELECTRONICS

Keep Buying  
WAR BONDS